

TABLE OF CONTENTS

FULL VIEW

Elevations: 1/8" Scale

A252

A5001

A5009

A5010

A5012

A5015

A5037

Additional Sidelight Options

A1101

A1103

A5701

A5705

Decorative Hardware

Glass Design Options

Decorative Grilles

Section Details

A252

A5001

A5009

A5010

A5012

A5015

A5037

A1101

A1103

A5701

A5705

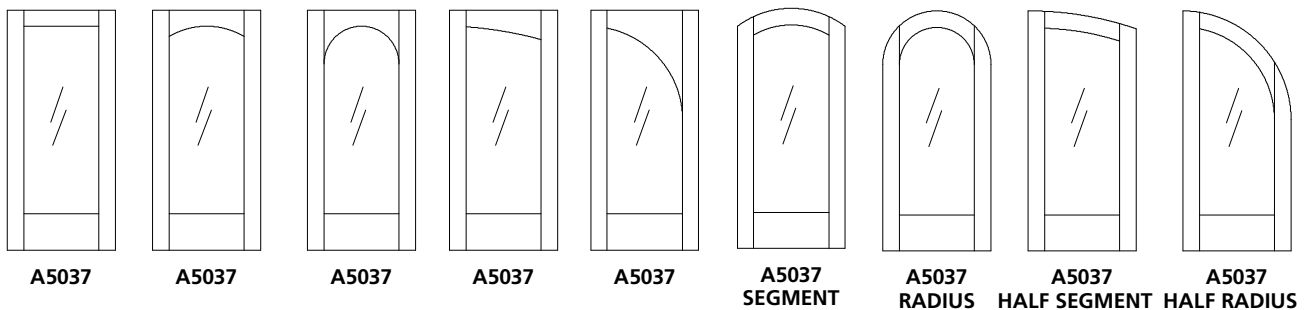
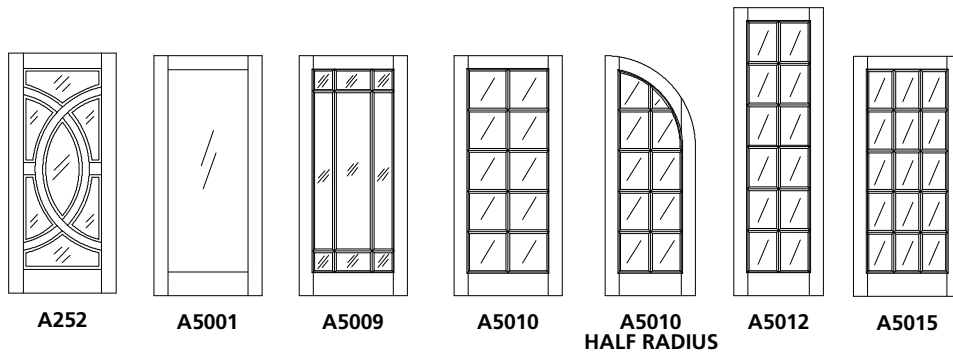

ELEVATION NOTES

Door Size = Book Size Before Prefit
Daylight Opening (DLO) = Visible Glass

Values in brackets [] are millimeter conversions.
See A252 Glass Detail Sheet for glass options.

DOOR CROSS-SECTION

Moulding Profile = 112
Panel Profile = Double Hip
See A252 Cross Section sheet for more detail.

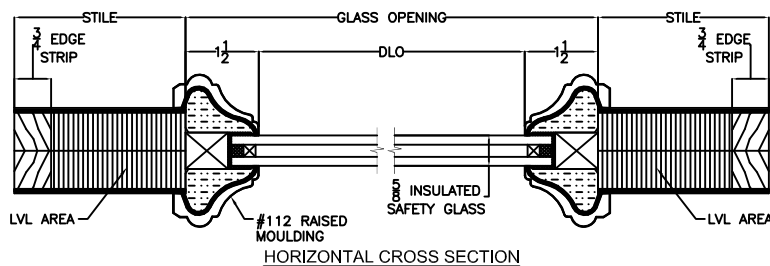
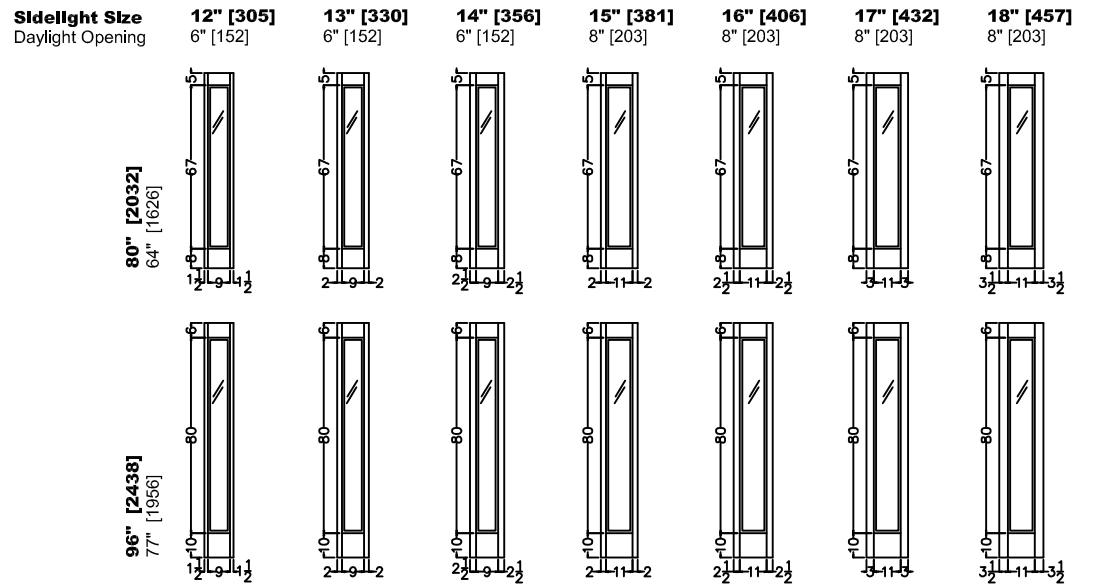
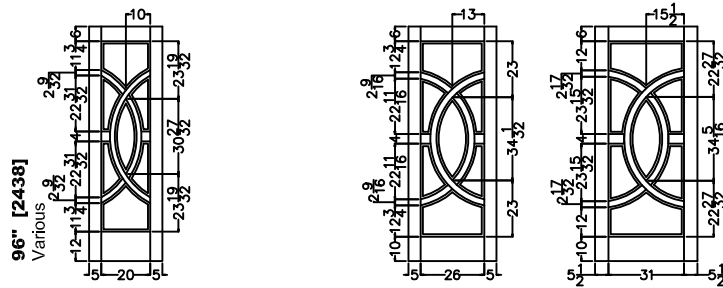
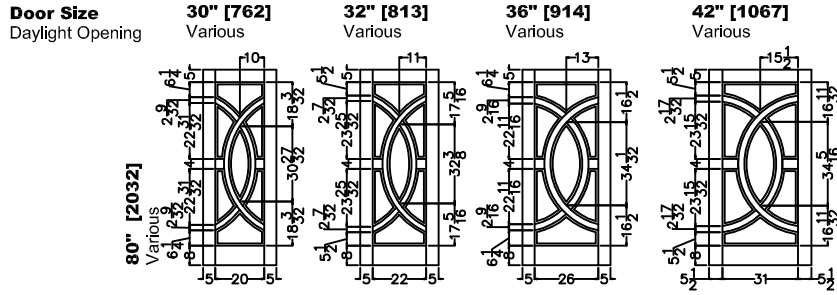
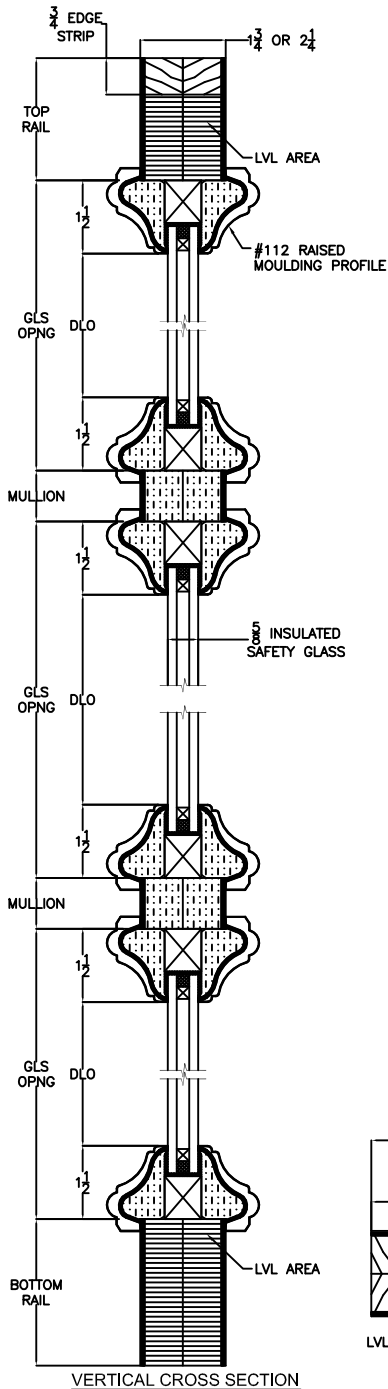

ELEVATION NOTES

Door Size = Book Size Before Prefit
Daylight Opening (DLO) = Visible Glass

Values in brackets [] are millimeter conversions.
Sidelight Match = A5701

DOOR CROSS-SECTION

Moulding Profile = 141
Panel Profile = n/a
See A5001 Cross Section sheet for more detail.

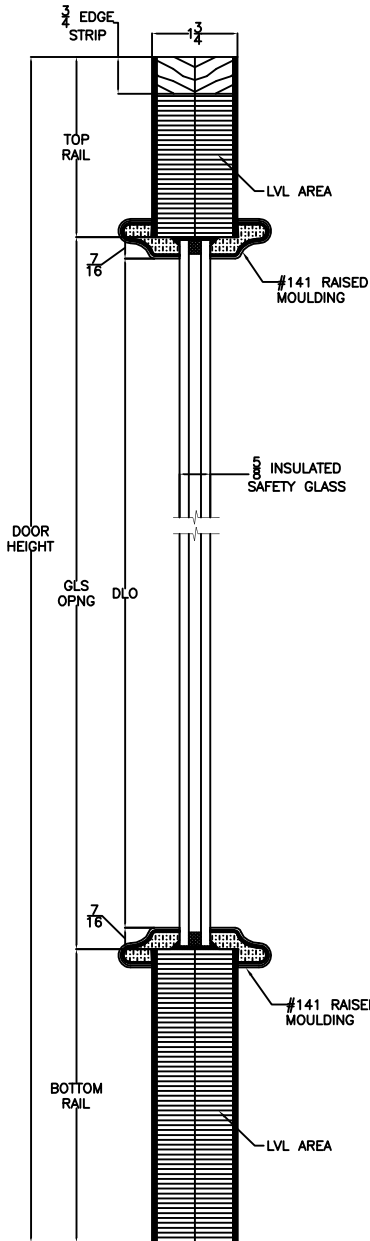

VERTICAL CROSS SECTION

Door Size
Daylight Opening

30" [762]
19 3/4" [502]

32" [813]
21 3/4" [552]

36" [914]
25 3/4" [654]

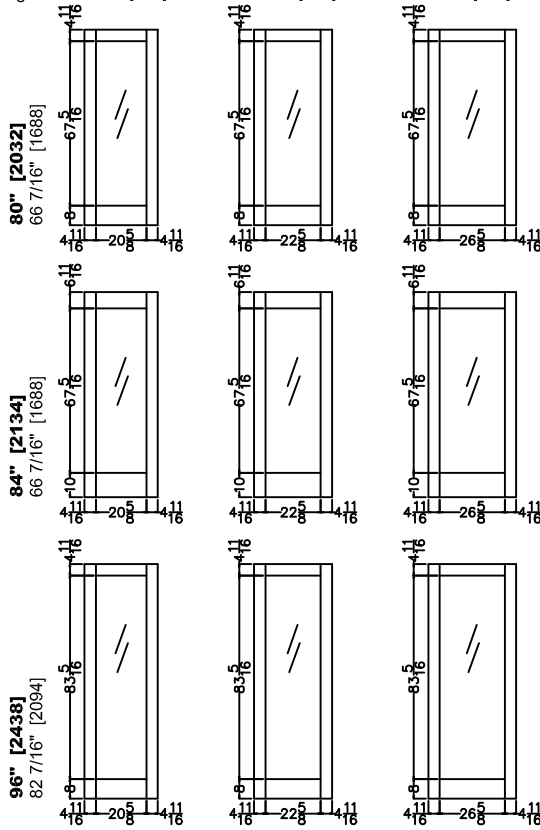

ELEVATION NOTES

Door Size = Book Size Before Prefit
Daylight Opening (DLO) = Visible Glass

Values in brackets [] are millimeter conversions.

DOOR CROSS-SECTION

Moulding Profile = 141
Panel Profile = n/a
See A5009 Cross Section sheet for more detail.

Door Size
Daylight Opening

32" [813]
Various

36" [914]
Various

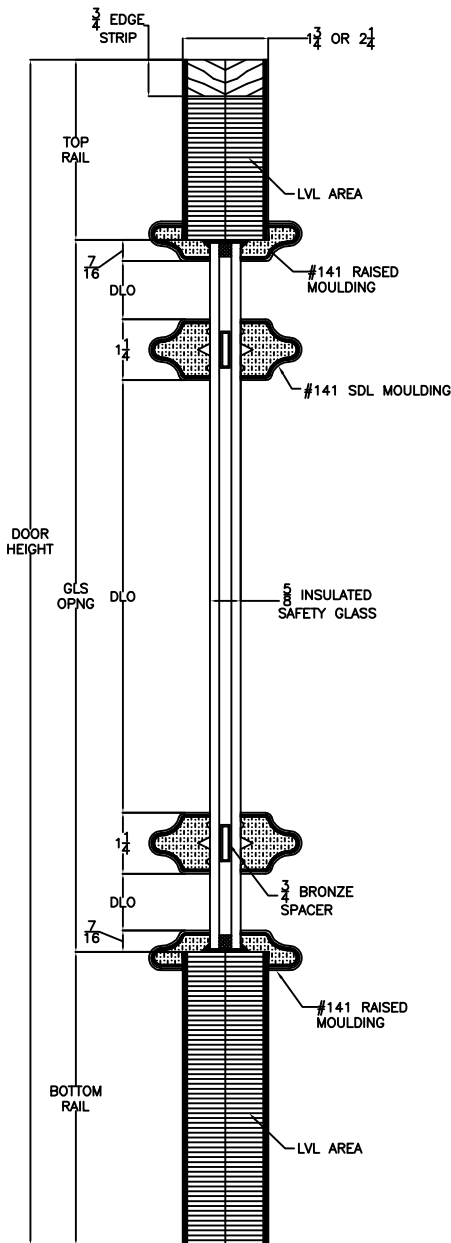
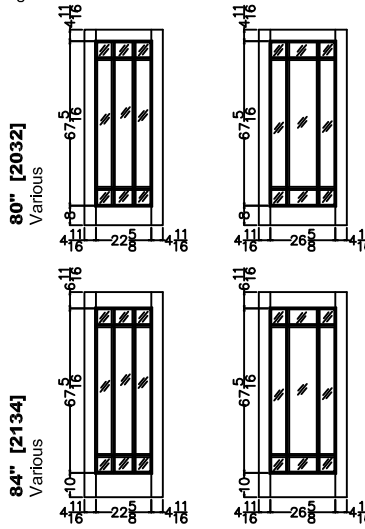

VERTICAL DOOR CROSS SECTION
Insulated Glass

ELEVATION NOTES

Door Size = Book Size Before Prefit
Daylight Opening (DLO) = Visible Glass

Values in brackets [] are millimeter conversions.
Sidelight Match = A5705 (Flat Top Only)

DOOR CROSS-SECTION

Moulding Profile = 141
Panel Profile = n/a
See A5010 Cross Section sheet for more detail.

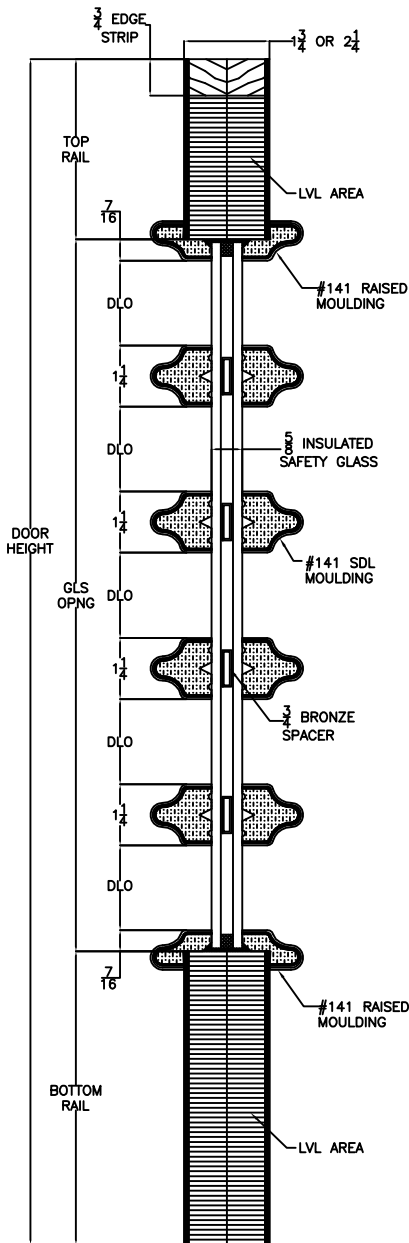

VERTICAL CROSS SECTION

FLAT TOP

Door Size
Daylight Opening

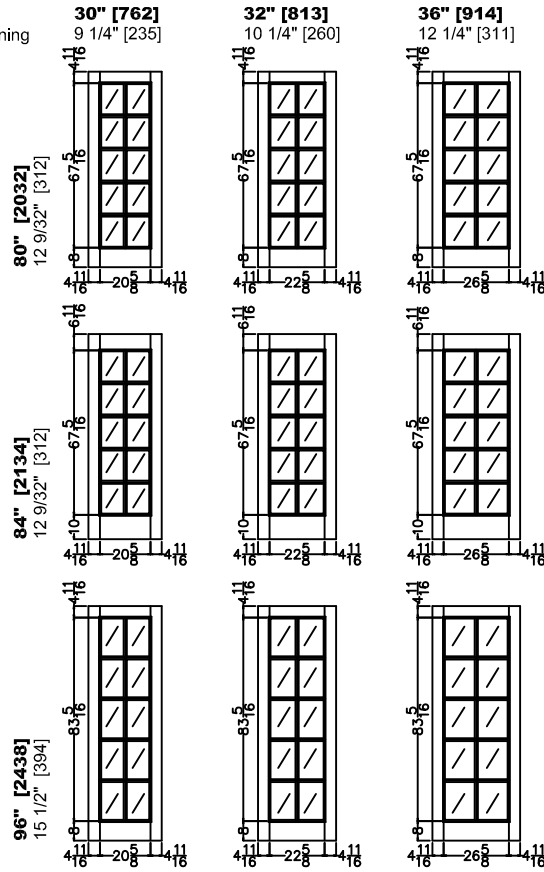

1/2 RADIUS TOP

Door Size
Daylight Opening

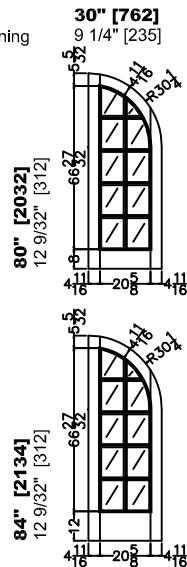

ELEVATION NOTES

Door Size = Book Size Before Prefit
Daylight Opening (DLO) = Visible Glass

Values in brackets [] are millimeter conversions.

DOOR CROSS-SECTION

Moulding Profile = 141
Panel Profile = n/a
See A5012 Cross Section sheet for more detail.

Door Size 30" [762]
Daylight Opening 9 1/4" [235]

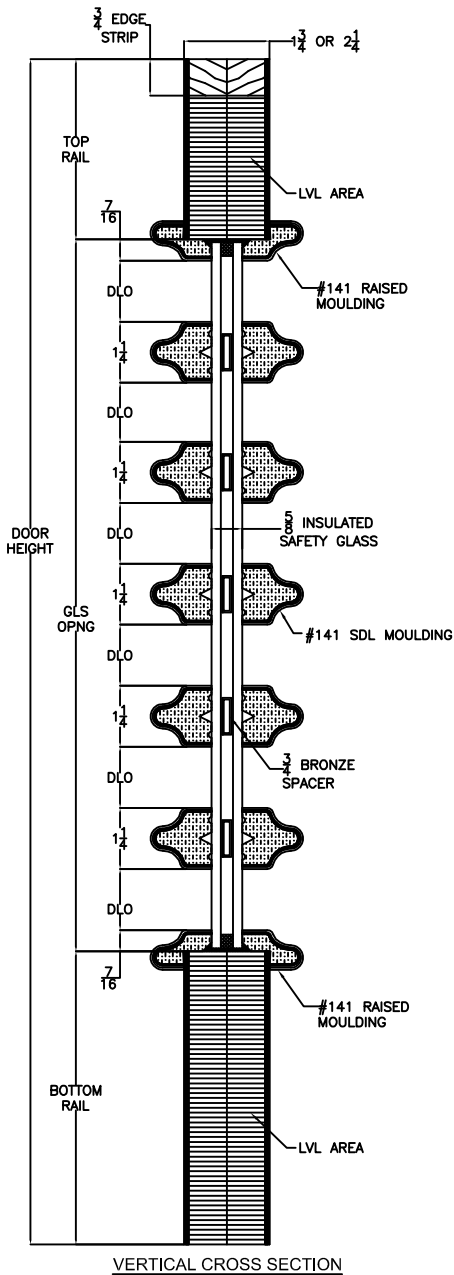
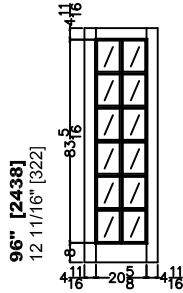

ELEVATION NOTES

Door Size = Book Size Before Prefit
Daylight Opening (DLO) = Visible Glass

Values in brackets [] are millimeter conversions.
Sidelight Match = A5705

DOOR CROSS-SECTION

Moulding Profile = 141
Panel Profile = n/a
See A5015 Cross Section sheet for more detail.

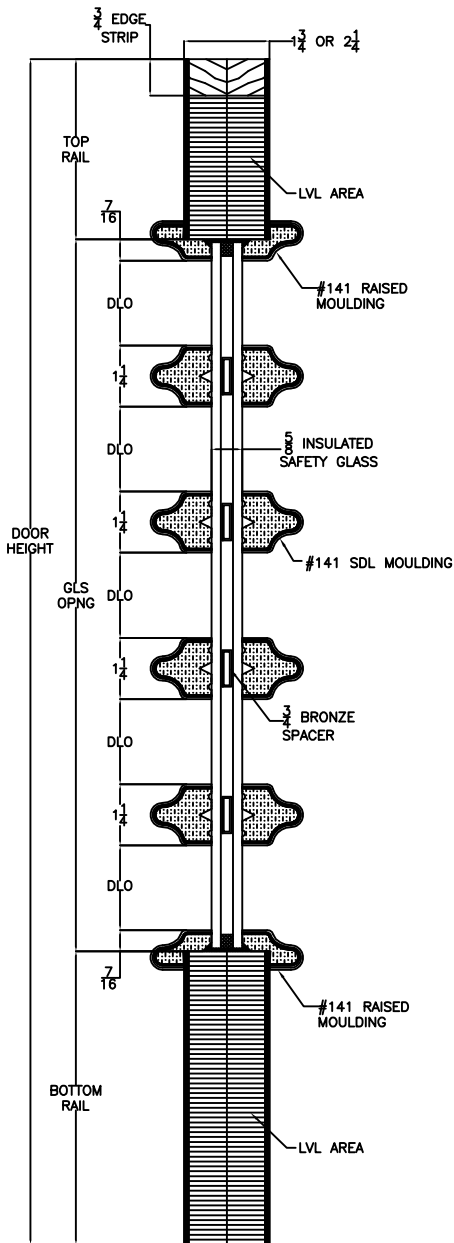

VERTICAL CROSS SECTION

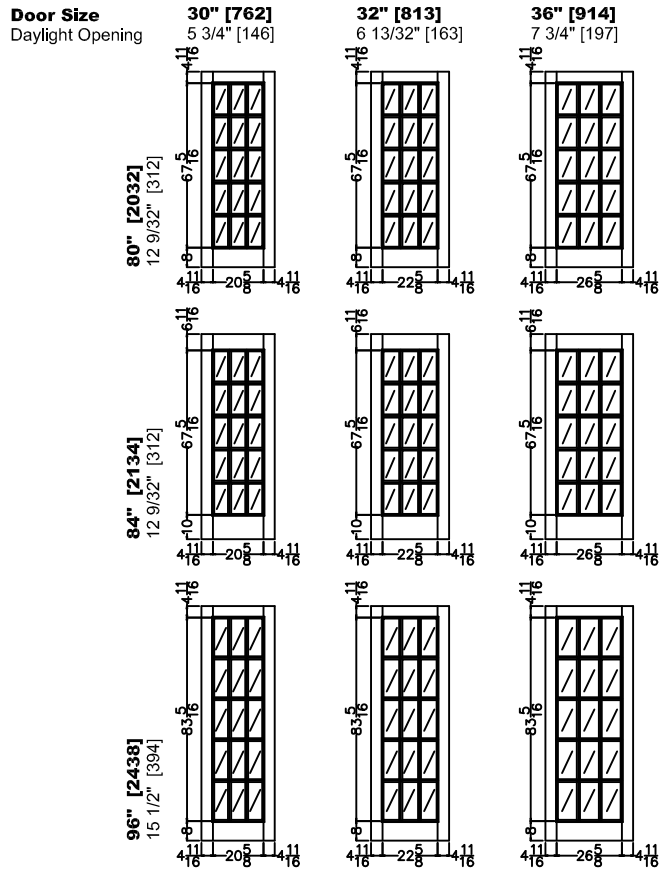

ELEVATION NOTES

Door Size = Book Size Before Prefit
Daylight Opening (DLO) = Visible Glass

Values in brackets [] are millimeter conversions.
Sidelight Match = A5037

DOOR CROSS-SECTION

Moulding Profile = 141
Panel Profile = n/a
See A5037 Cross Section sheet for more detail.

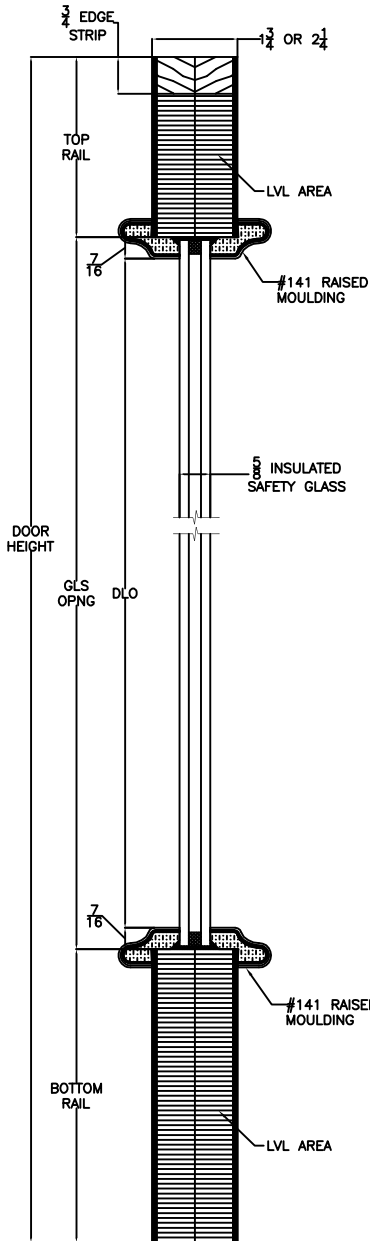

VERTICAL CROSS SECTION

Door Size
Daylight Opening

30" [762]
18 1/8" [460]

32" [813]
20 1/8" [511]

36" [914]
24 1/8" [613]

42" [1067]
30 1/8" [765]

SPECIAL LITES

36" [914]
Various

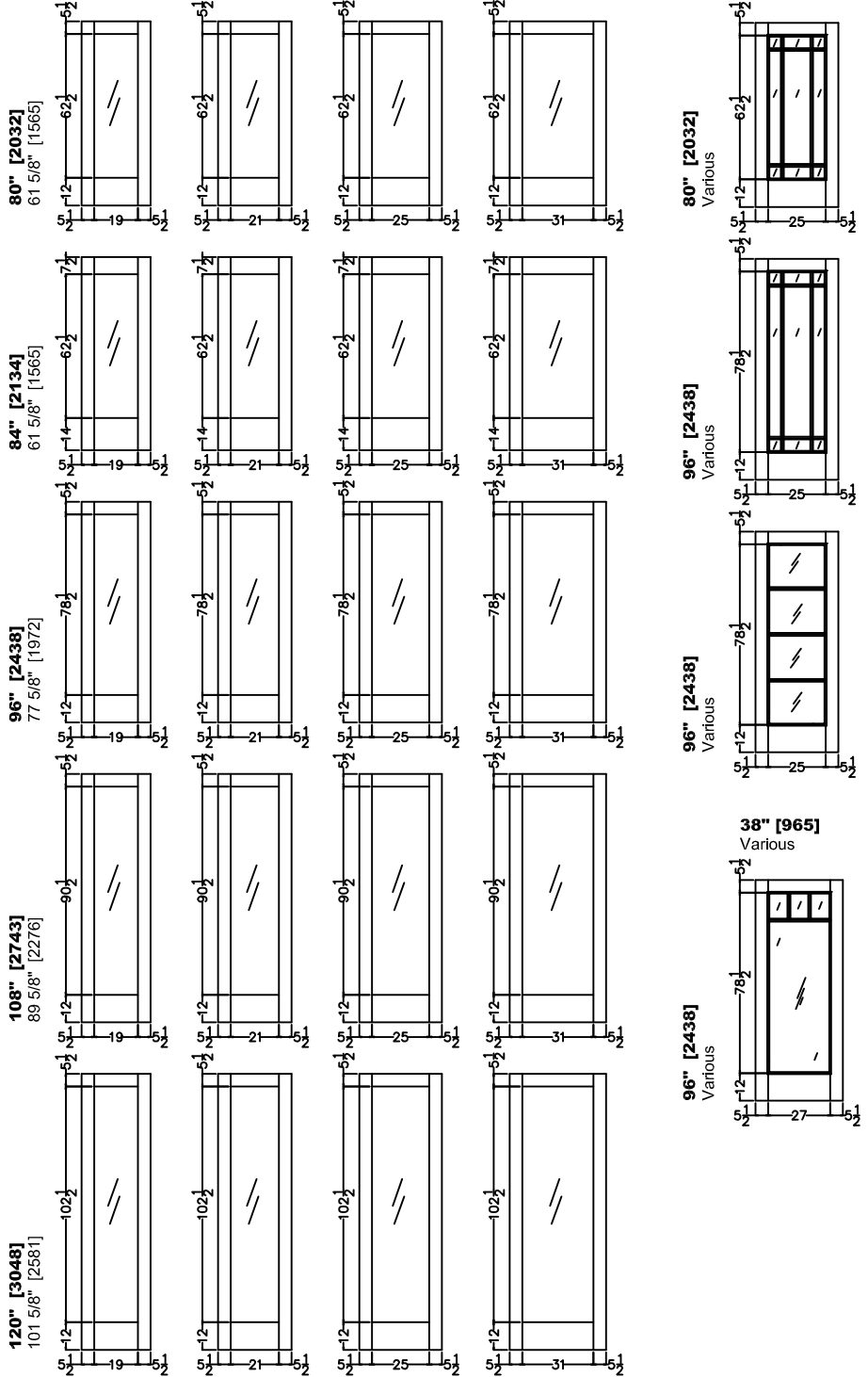

ELEVATION NOTES

Door Size = Book Size Before Prefit
 Daylight Opening (DLO) = Visible Glass

Values in brackets [] are millimeter conversions.

DOOR CROSS-SECTION

Moulding Profile = 141
 Panel Profile = n/a
 See A5037 Cross Section sheet for more detail.

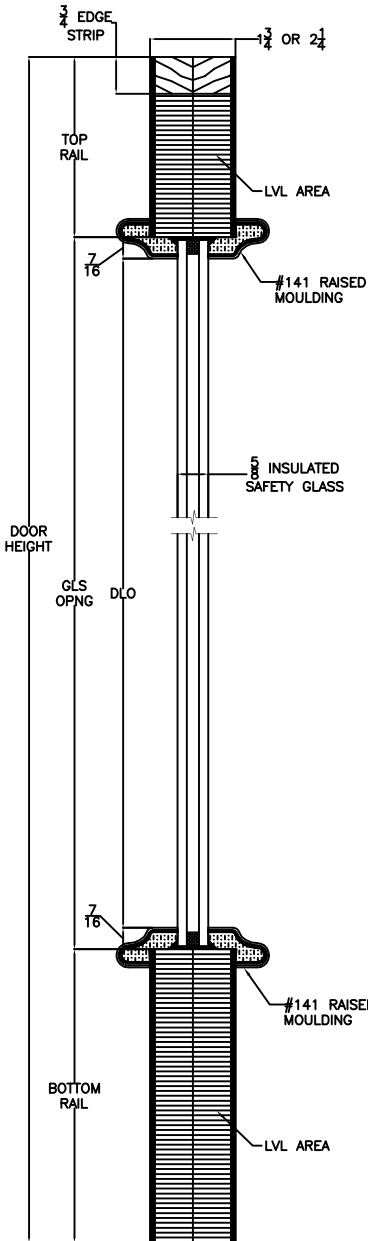

VERTICAL CROSS SECTION

Door Size	30" [762]	32" [813]	36" [914]	42" [1067]
Daylight Opening	18 1/8" [460]	20 1/8" [511]	24 1/8" [613]	30 1/8" [765]
80" [2032] 61 5/8" [1565]				
84" [2134] 61 5/8" [1565]				
96" [2438] 77 5/8" [1972]				
108" [2743] 89 5/8" [2276]				
120" [3048] 101 5/8" [2581]				

ELEVATION NOTES

Door Size = Book Size Before Prefit
 Daylight Opening (DLO) = Visible Glass

Values in brackets [] are millimeter conversions.
 Sidelight Match = A5037

DOOR CROSS-SECTION

Moulding Profile = 141
 Panel Profile = n/a
 See A5037 Cross Section sheet for more detail.

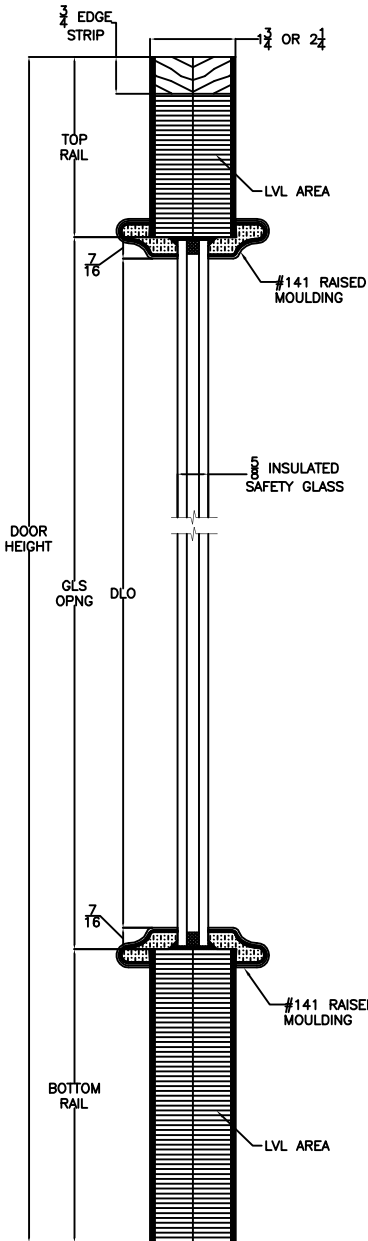

VERTICAL CROSS SECTION

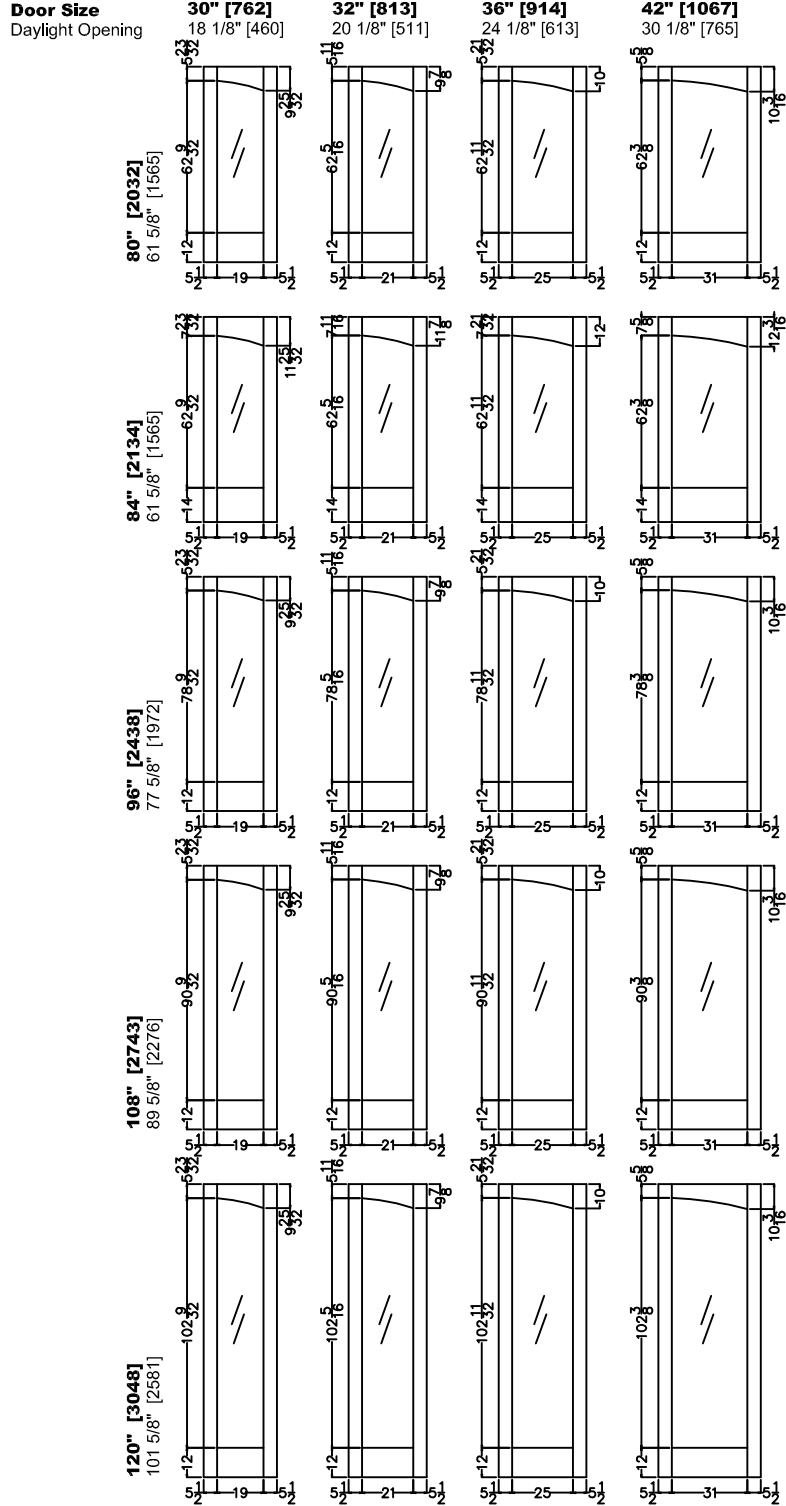

ELEVATION NOTES

Door Size = Book Size Before Prefit
Daylight Opening (DLO) = Visible Glass

Values in brackets [] are millimeter conversions.
Sidelight Match = A5037

DOOR CROSS-SECTION

Moulding Profile = 141
Panel Profile = n/a
See A5037 Cross Section sheet for more detail.

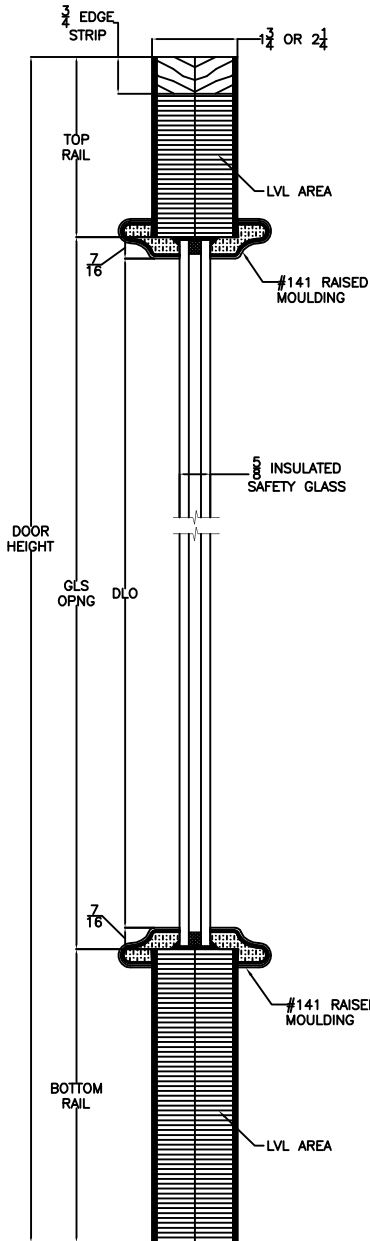

VERTICAL CROSS SECTION

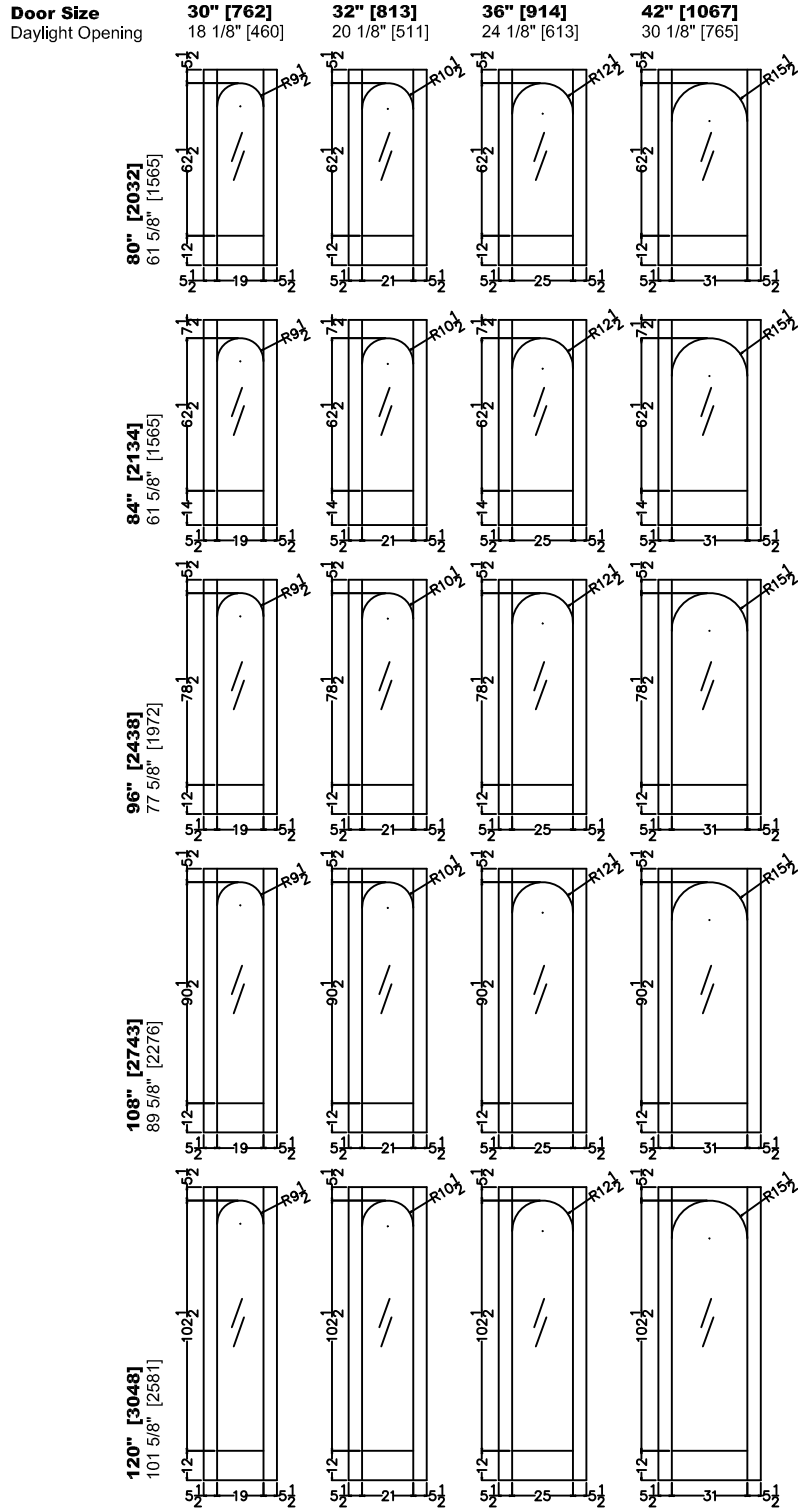

ELEVATION NOTES

Door Size = Book Size Before Prefit
 Daylight Opening (DLO) = Visible Glass

Values in brackets [] are millimeter conversions.
 Sidelight Match = A5037

DOOR CROSS-SECTION

Moulding Profile = 141
 Panel Profile = n/a
 See A5037 Cross Section sheet for more detail.

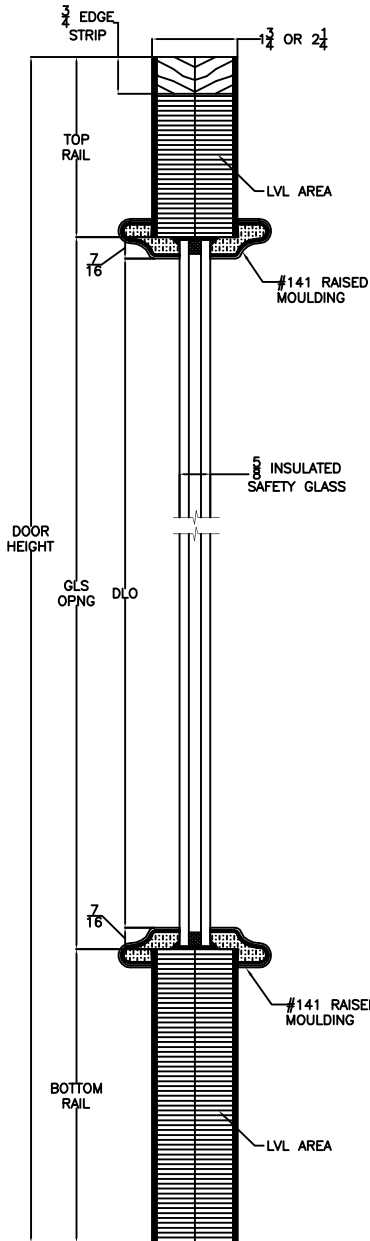

VERTICAL CROSS SECTION

Door Size
 Daylight Opening

30" [762]
 18 1/8" [460]

32" [813]
 20 1/8" [511]

36" [914]
 24 1/8" [613]

42" [1067]
 30 1/8" [765]

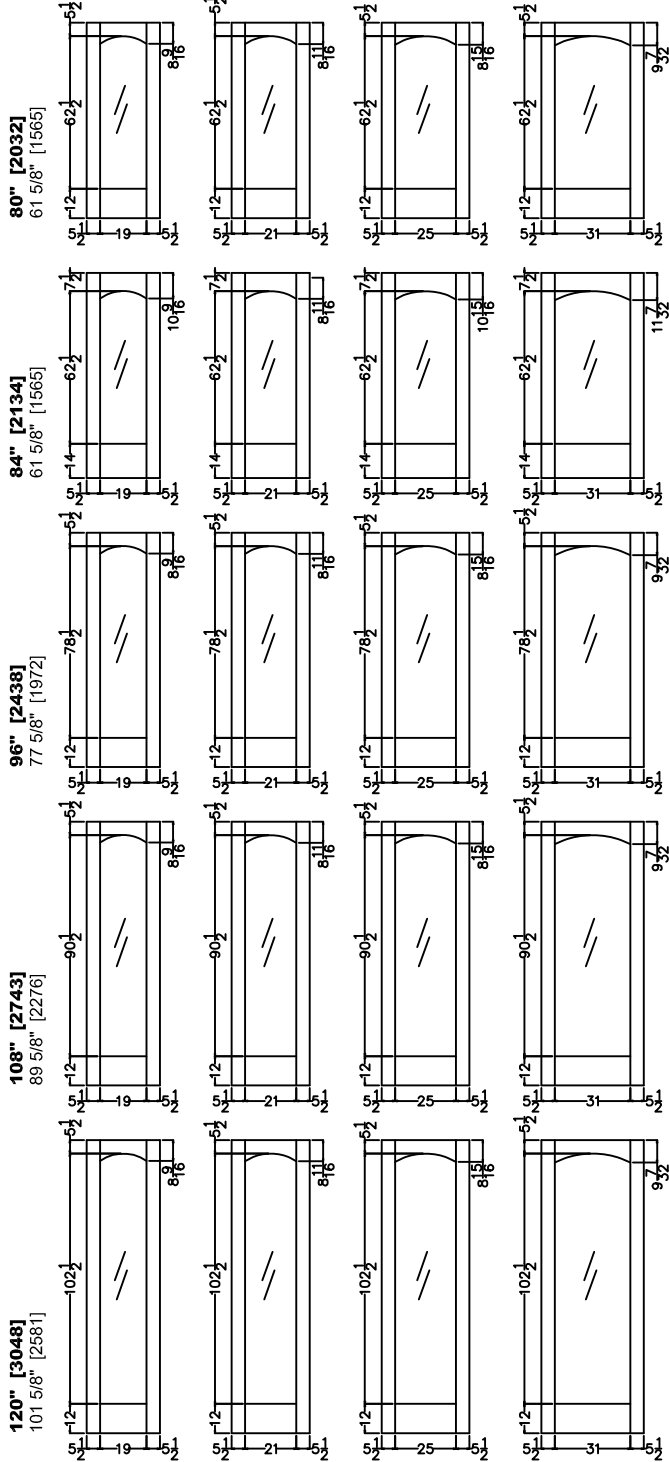

ELEVATION NOTES

Door Size = Book Size Before Prefit
Daylight Opening (DLO) = Visible Glass

Values in brackets [] are millimeter conversions.

DOOR CROSS-SECTION

Moulding Profile = 141
Panel Profile = n/a
See A5037 Cross Section sheet for more detail.

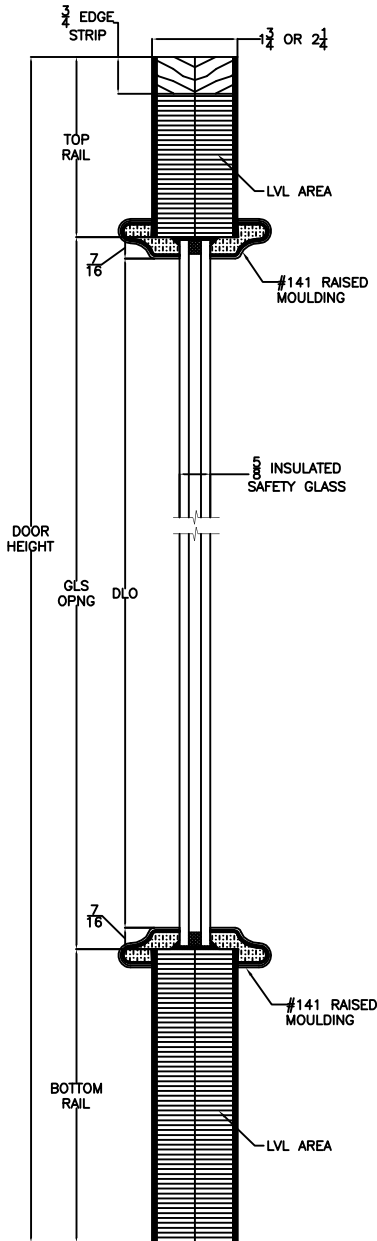

VERTICAL CROSS SECTION

	30" [762] 18 1/8" [460]	32" [813] 20 1/8" [511]	36" [914] 24 1/8" [613]	42" [1067] 30 1/8" [765]
80" [2032] 61 5/8" [1565]				
84" [2134] 61 5/8" [1565]				
96" [2438] 77 5/8" [1972]				
108" [2743] 89 5/8" [2276]				
120" [3048] 101 5/8" [2581]				

ELEVATION NOTES

Door Size = Book Size Before Prefit
Daylight Opening (DLO) = Visible Glass

Values in brackets [] are millimeter conversions.
Sidelight Match = A5037

DOOR CROSS-SECTION

Moulding Profile = 141
Panel Profile = n/a
See A5037 Cross Section sheet for more detail.

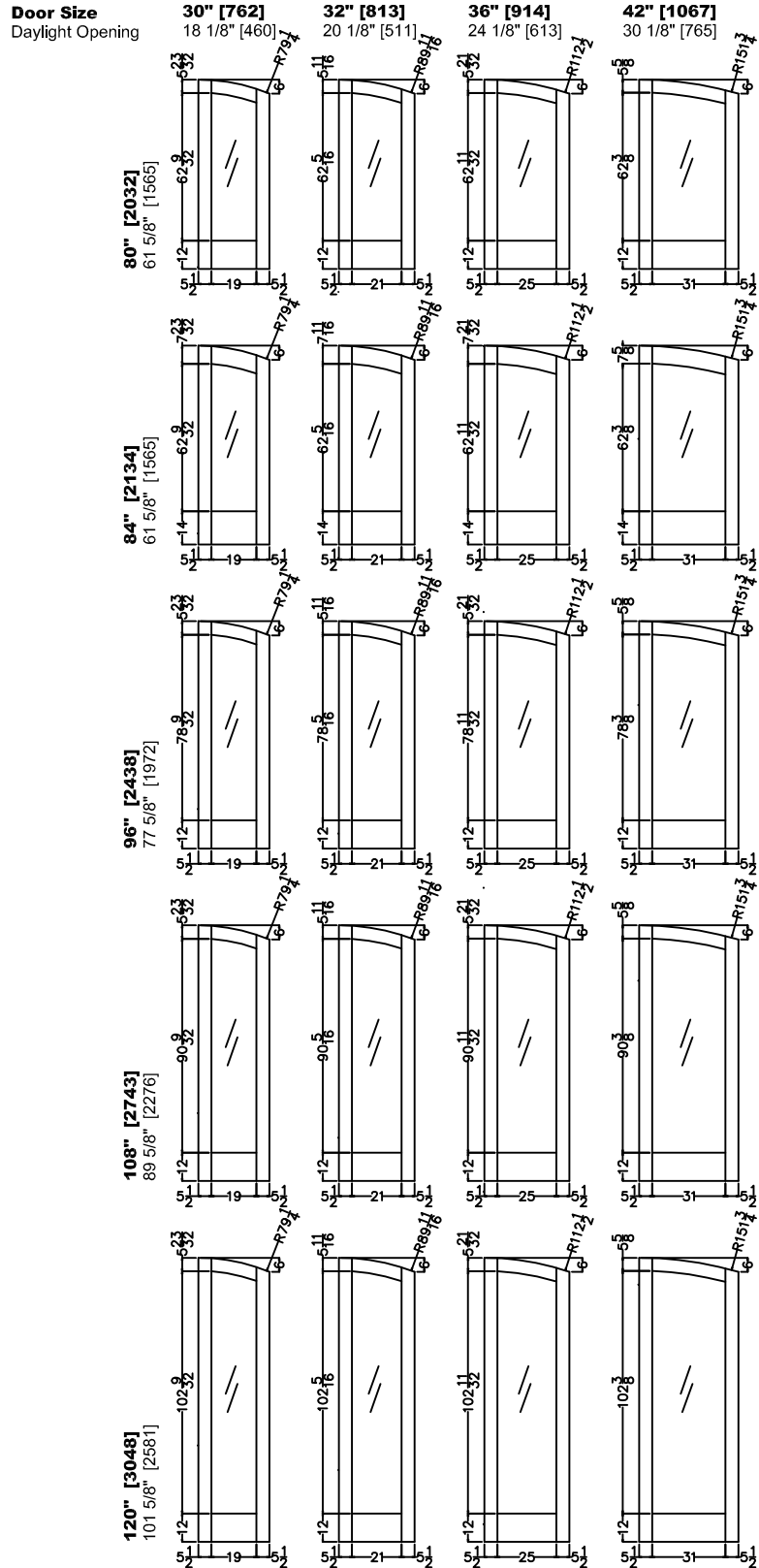
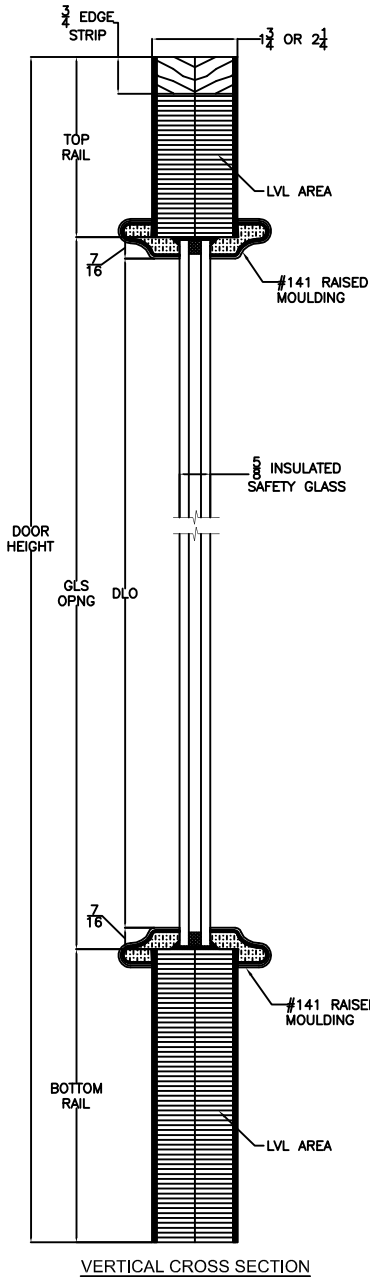

ELEVATION NOTES

Door Size = Book Size Before Prefit
Daylight Opening (DLO) = Visible Glass

Values in brackets [] are millimeter conversions.

DOOR CROSS-SECTION

Moulding Profile = 141
Panel Profile = n/a
See A5037 Cross Section sheet for more detail.

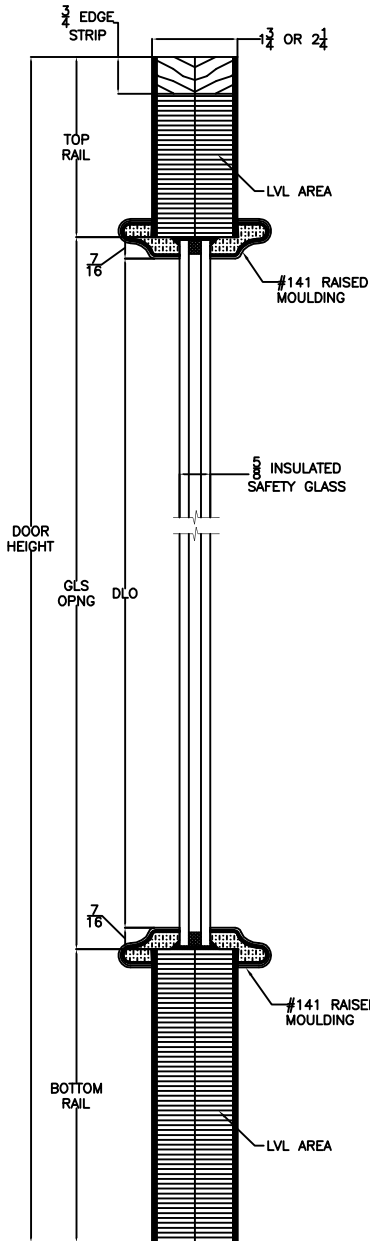

Door Size
Daylight Opening

30" [762]
18 1/8" [460]

32" [813]
20 1/8" [511]

36" [914]
24 1/8" [613]

42" [1067]
30 1/8" [765]

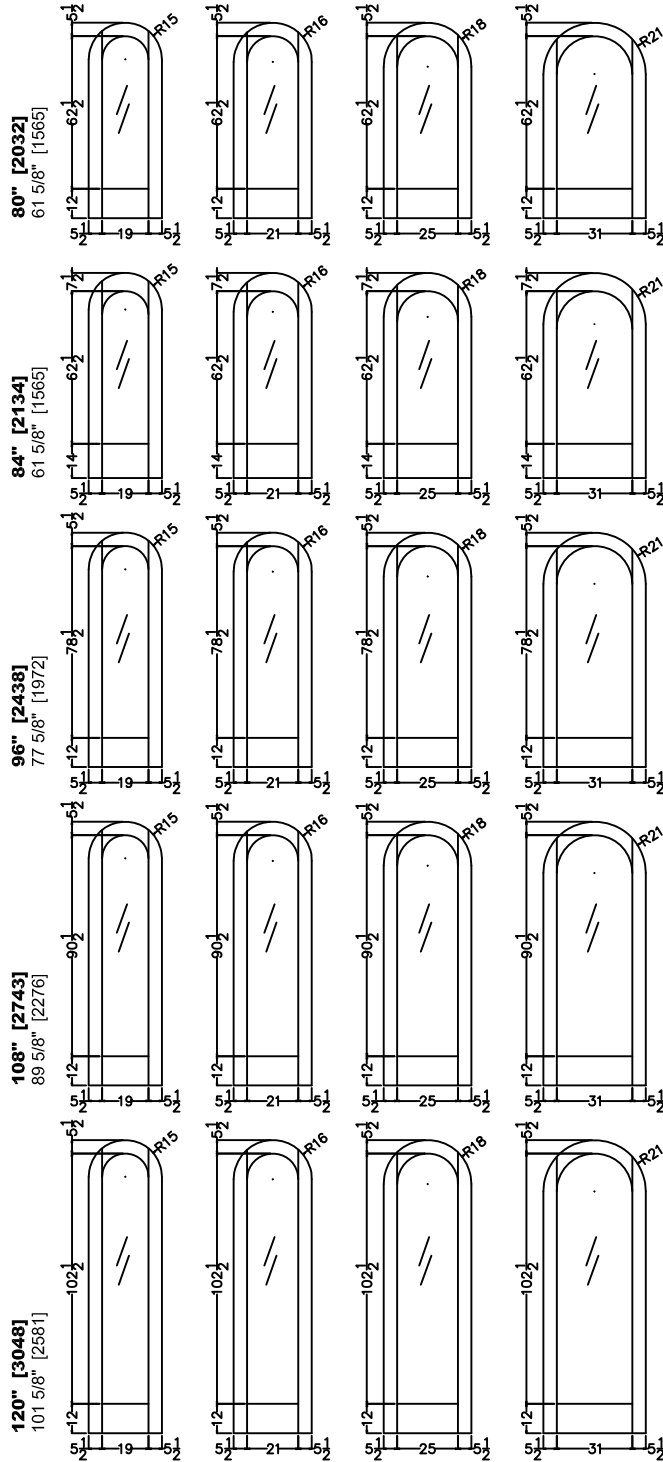

VERTICAL CROSS SECTION

ELEVATION NOTES

Door Size = Book Size Before Prefit
Daylight Opening (DLO) = Visible Glass

Values in brackets [] are millimeter conversions.

DOOR CROSS-SECTION

Moulding Profile = 141
Panel Profile = n/a
See A5037 Cross Section sheet for more detail.

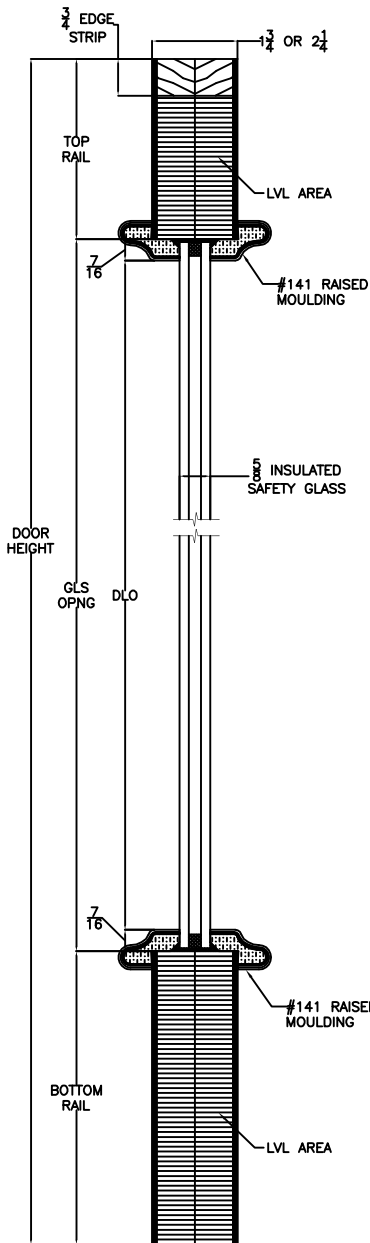

VERTICAL CROSS SECTION

Door Size
Daylight Opening

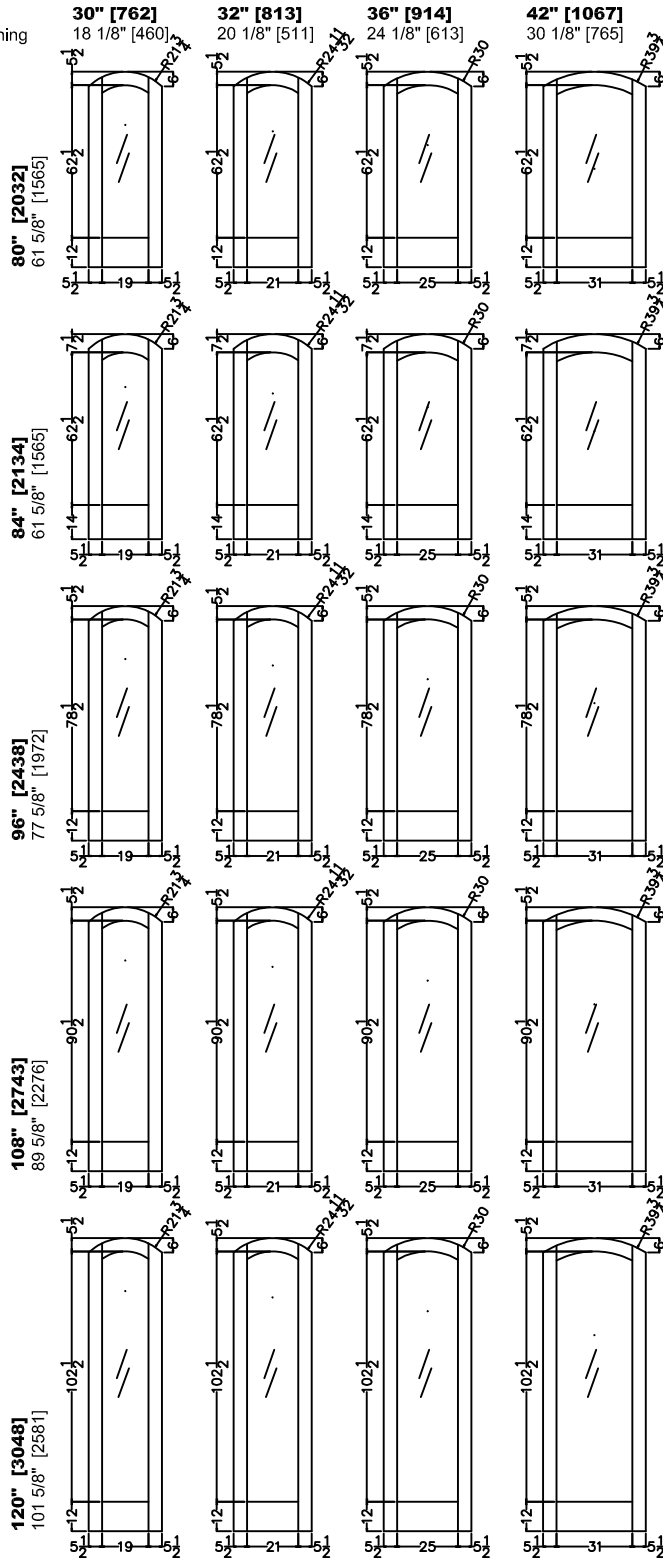

ELEVATION NOTES

Door Size = Book Size Before Prefit
Daylight Opening (DLO) = Visible Glass

Values in brackets [] are millimeter conversions.

DOOR CROSS-SECTION

Moulding Profile = 141
Panel Profile = n/a
See A5037 Cross Section sheet for more detail.

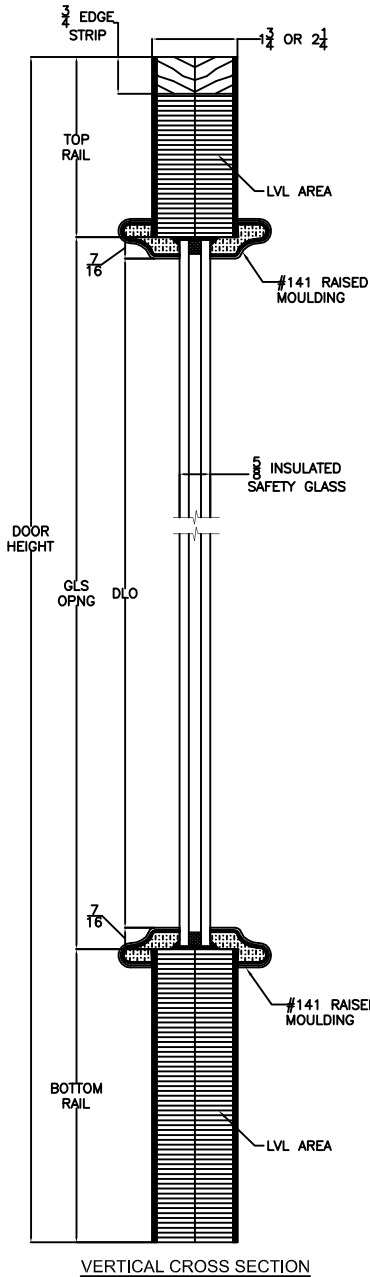

FLAT SIDELIGHT EXAMPLE

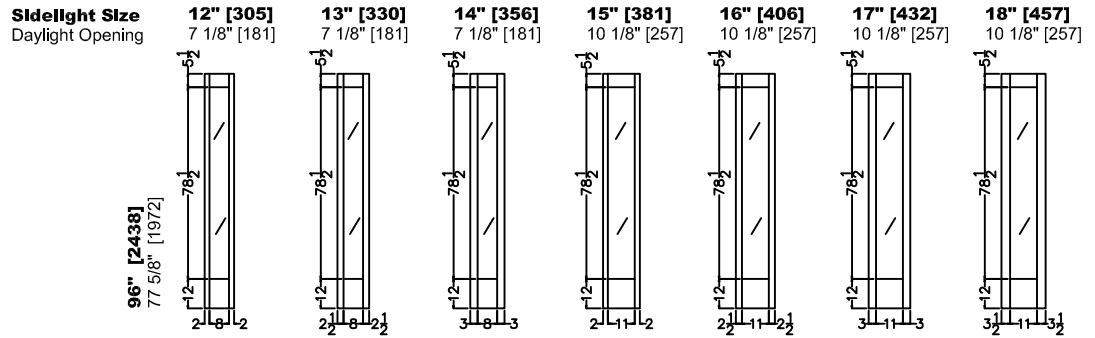

FLAT SIDELIGHT W/ SEGMENT GLASS EXAMPLE

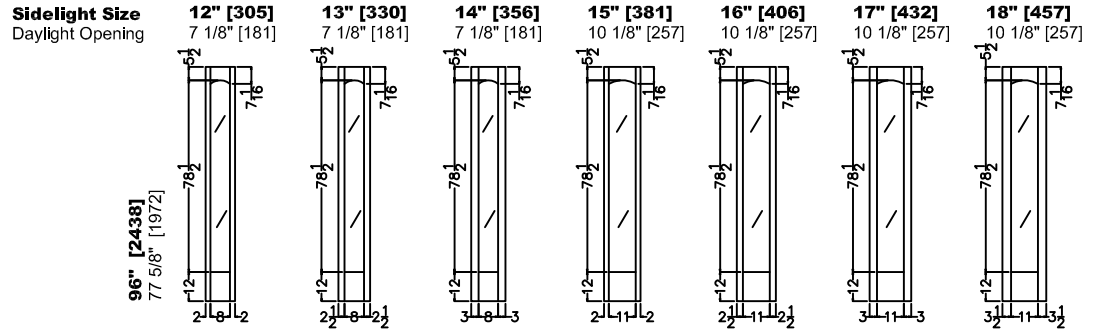

FLAT SIDELIGHT W/ RADIUS GLASS EXAMPLE

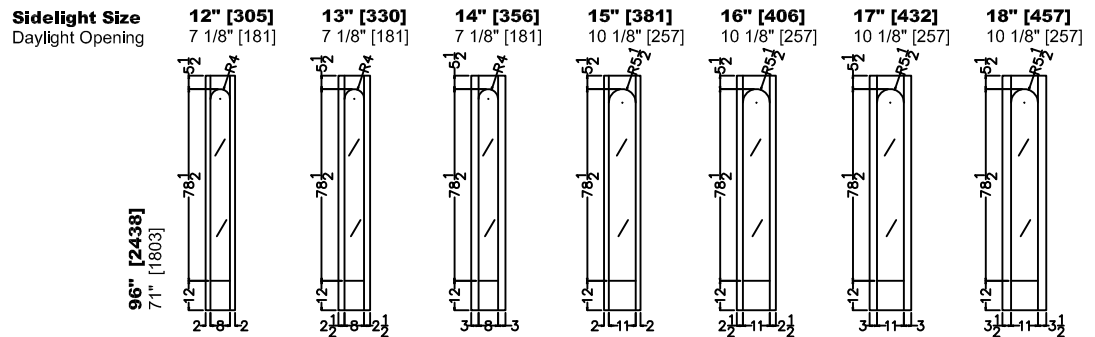

FLAT SIDELIGHT W/ 1/2 SEGMENT GLASS EXAMPLE

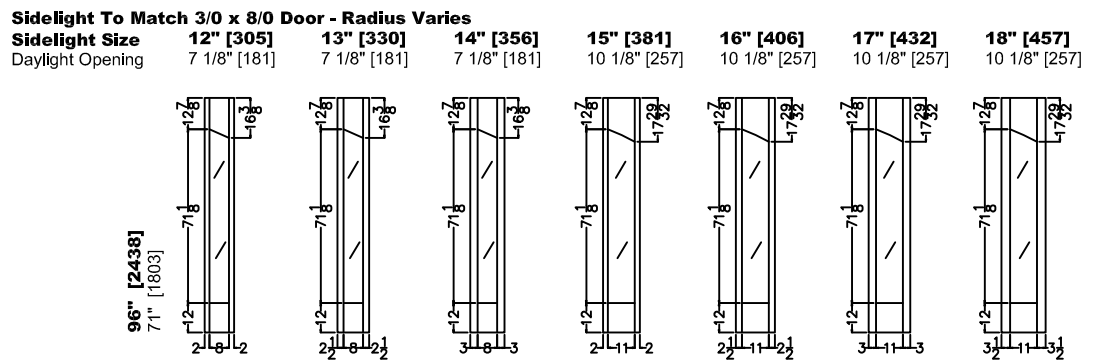

1/2 SEGMENT SIDELIGHT EXAMPLE

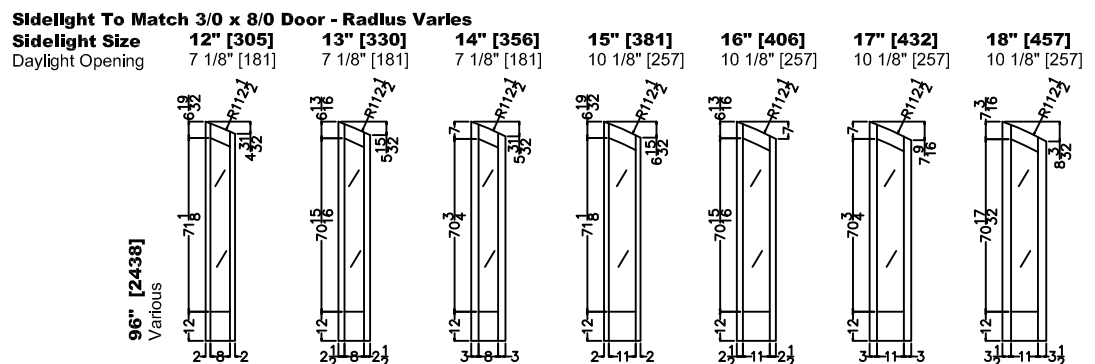

ELEVATION NOTES

Door Size = Book Size Before Prefit
Daylight Opening (DLO) = Visible Glass

Values in brackets [] are millimeter conversions.
See A1101 Glass Detail Sheet for glass options.

DOOR CROSS-SECTION

Moulding Profile = 141
Panel Profile = n/a
See A1101 Cross Section sheet for more detail.

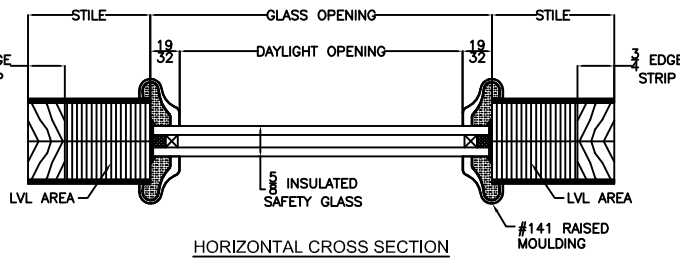
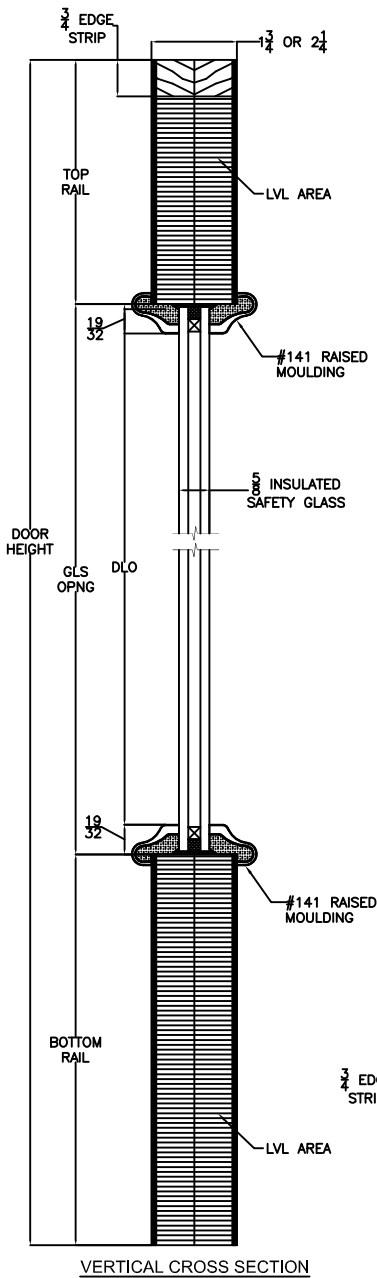

Sidelight Size	12" [305]	13" [330]	14" [356]	15" [381]	16" [406]	17" [432]	18" [457]
Daylight Opening	5 13/16" [148]	5 13/16" [148]	5 13/16" [148]	5 13/16" [148]	9 13/16" [249]	9 13/16" [249]	9 13/16" [249]

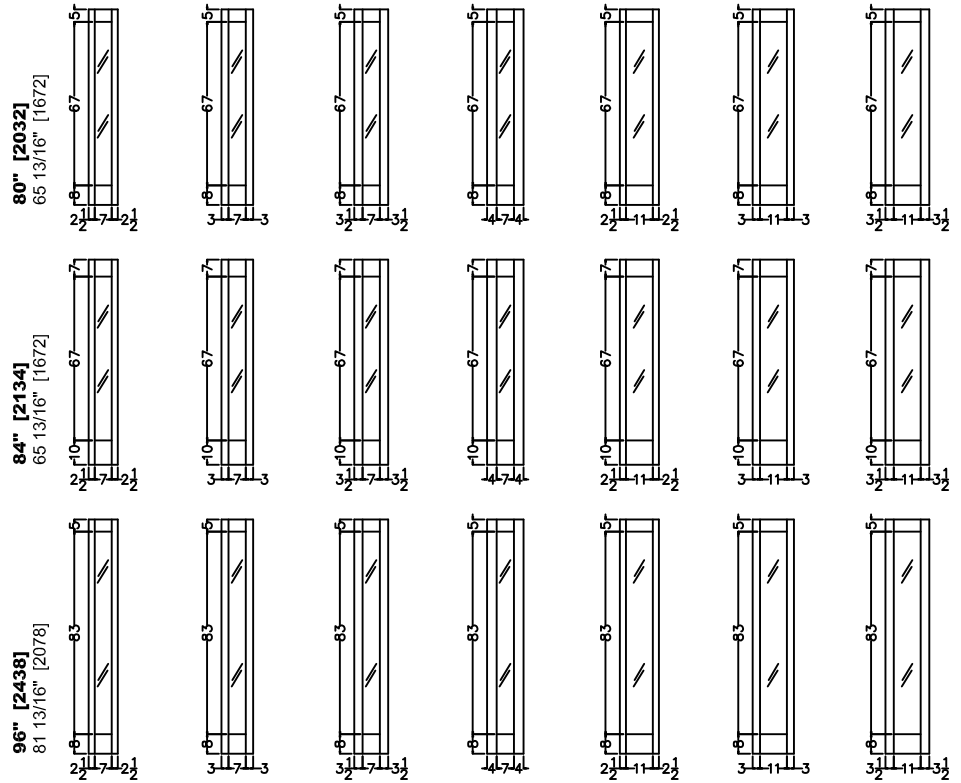

ELEVATION NOTES

Door Size = Book Size Before Prefit
Daylight Opening (DLO) = Visible Glass

Values in brackets [] are millimeter conversions.
See A1103 Glass Detail Sheet for glass options.

DOOR CROSS-SECTION

Moulding Profile = Square
Panel Profile = n/a
See A1103 Cross Section sheet for more detail.

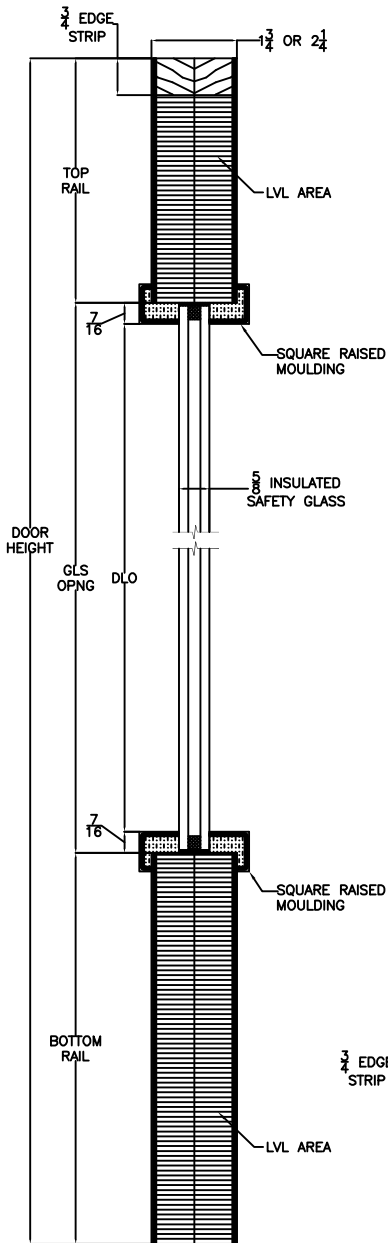

VERTICAL CROSS SECTION

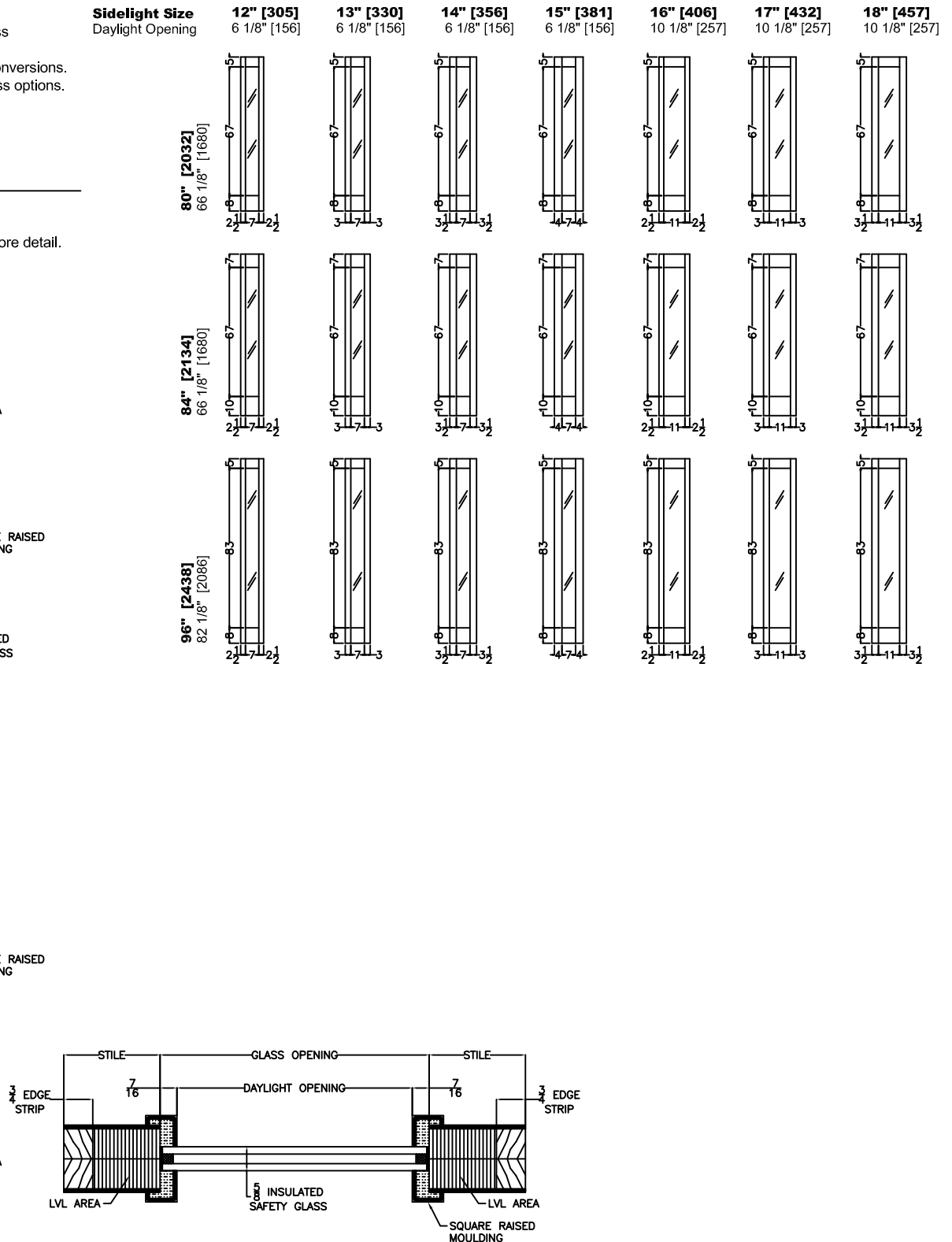

HORIZONTAL CROSS SECTION

ELEVATION NOTES

Door Size = Book Size Before Prefit
Daylight Opening (DLO) = Visible Glass

Values in brackets [] are millimeter conversions.

DOOR CROSS-SECTION

Moulding Profile = 141
Panel Profile = n/a
See A5701 Cross Section sheet for more detail.

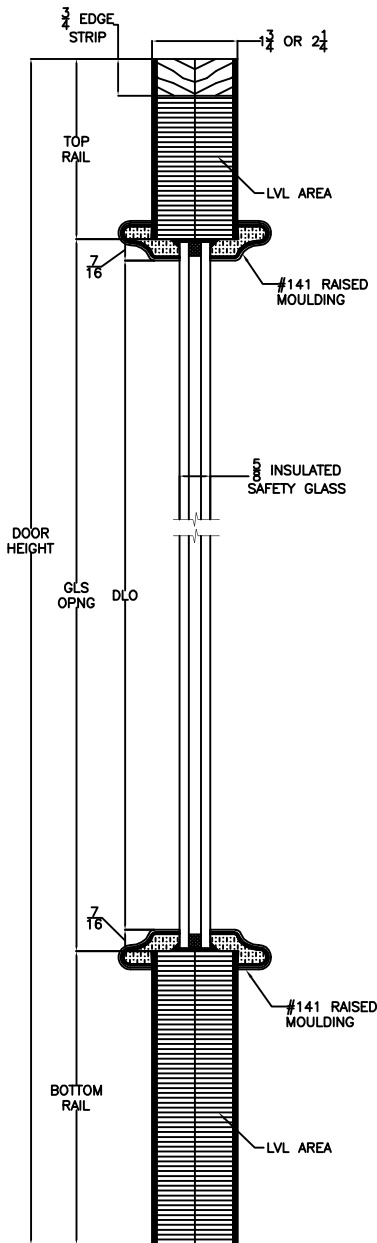

VERTICAL CROSS SECTION

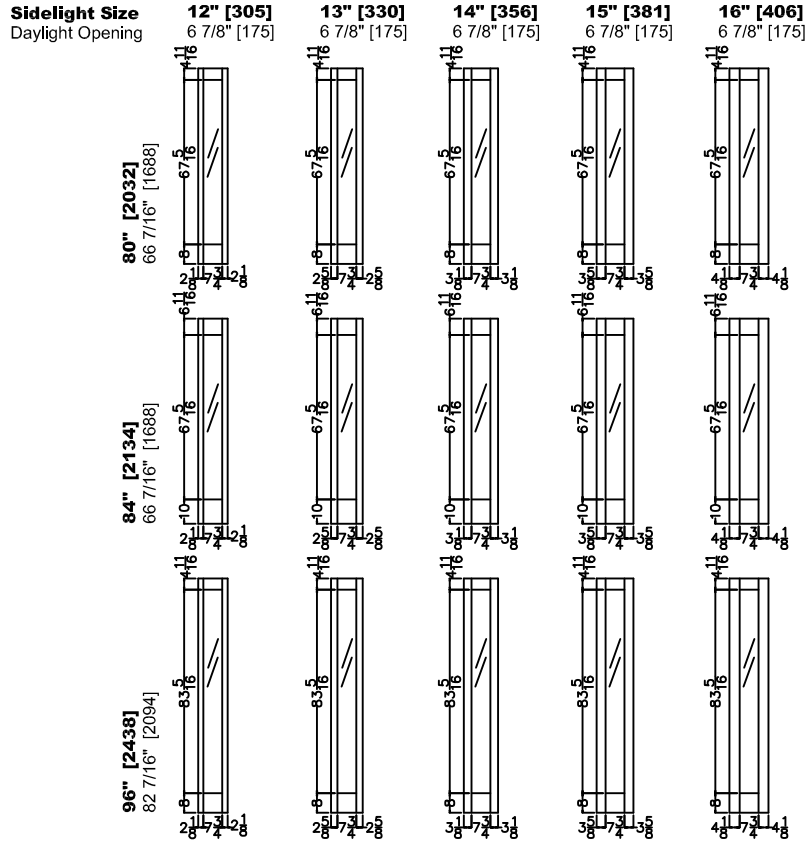

ELEVATION NOTES

Door Size = Book Size Before Prefit
Daylight Opening (DLO) = Visible Glass

Values in brackets [] are millimeter conversions.

DOOR CROSS-SECTION

Moulding Profile = 141
Panel Profile = n/a
See A5705 Cross Section sheet for more detail.

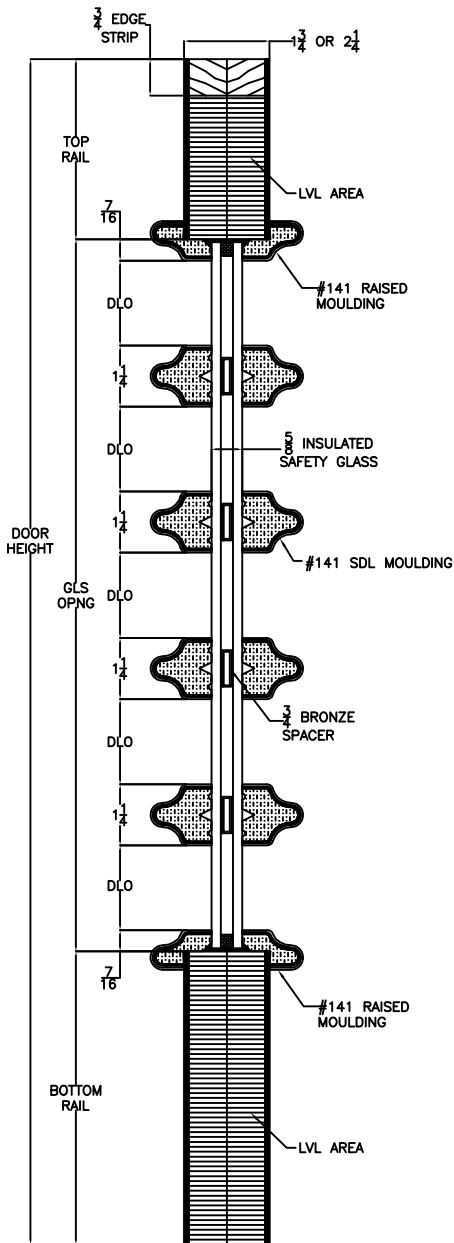

VERTICAL CROSS SECTION

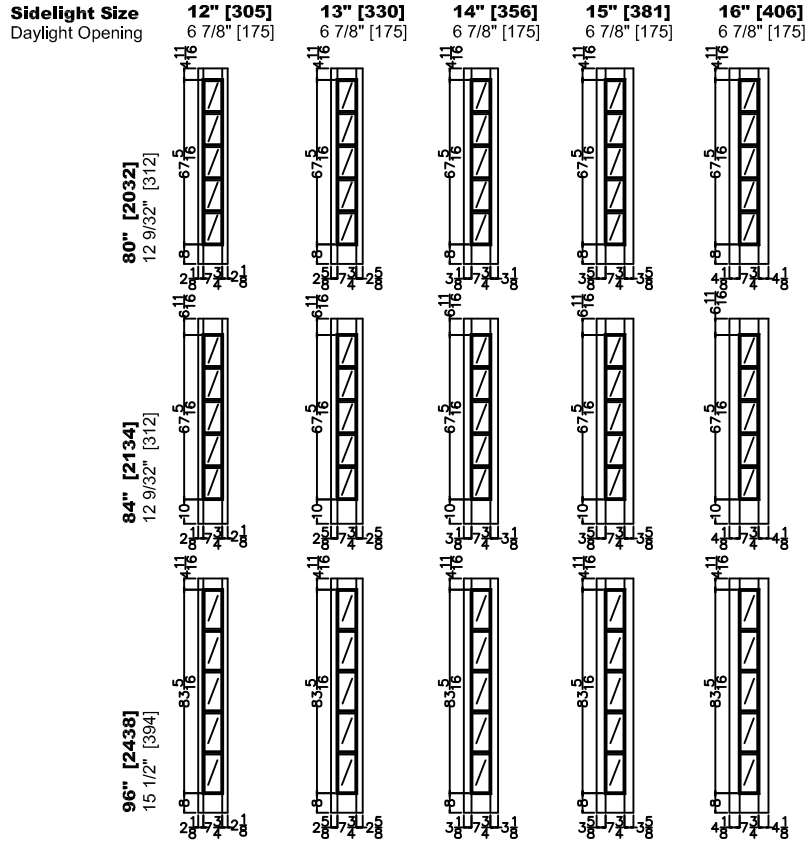



ROUND CLAVOS

Size Options: 1" diameter, 1.75" diameter
Finish Options: Dark Patina, Rust Patina
Material: Composite



DIAMOND CLAVOS

Size Options: 1", 1.75"
Finish Options: Dark Patina, Rust Patina
Material: Composite

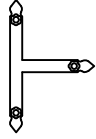

RAIL STRAP

Finish Options: Dark Patina, Rust Patina
Material: Composite



CORNER STRAP

Finish Options: Dark Patina, Rust Patina
Material: Composite

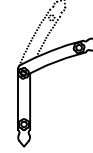

RADIUS STRAP

Finish Options: Dark Patina, Rust Patina
Material: Composite
Adjustable for Segment/Radius Shapes

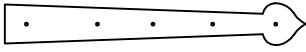

EXTENDED STRAP

Size: 25" x 3 1/4"
Finish Options: Dark Patina, Rust Patina
Material: Composite

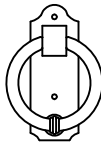

COLONIAL DOOR KNOCKER

Base: 2" Wide x 5 5/8" Tall, Handle: 4" Wide
Finish Options: Dark Patina, Rust Patina
Material: Composite



FLEUR de LIS DOOR KNOCKER

Base + Handle: 3 3/4" Wide x 4 7/8" Tall
Finish Options: Dark Patina, Rust Patina
Material: Composite

SPEAKEASY/DOOR LIGHT

Glass Options: Clear IG, Clear SG, Bevel IG, Bevel SG, Glue Chip IG,
Low E IG, Rain IG, Reed IG, Frosted IG, Open for Glass
Handing: Will be Handed to Match the Door unless Otherwise Specified
Frame Size: 12" x 15", Daylight Opening: 8" x 11", Actual Glass Size: 8 7/8" x 11 7/8"

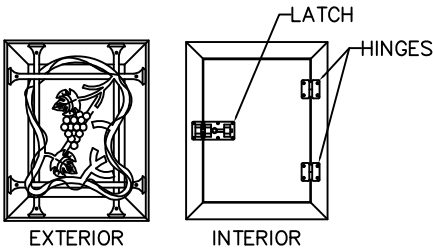

BORDEAUX SPEAKEASY

Hardware Finish Options: Dark Patina, Rust Patina
Material: Composite (Aluminum Hardware)

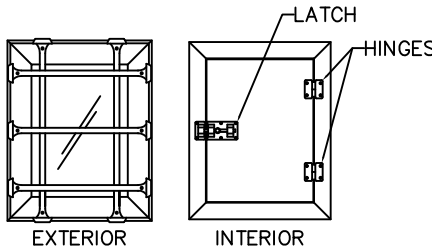

RUSTIC SPEAKEASY

Hardware Finish Options: Dark Patina, Rust Patina
Material: Composite (Aluminum Hardware)

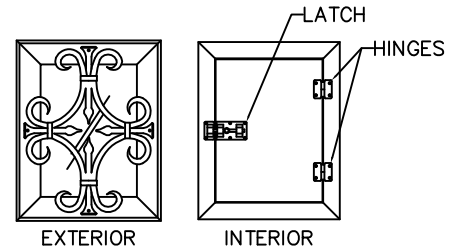

SEVILLE SPEAKEASY

Hardware Finish Options: Dark Patina, Rust Patina
Material: Composite (Aluminum Hardware)

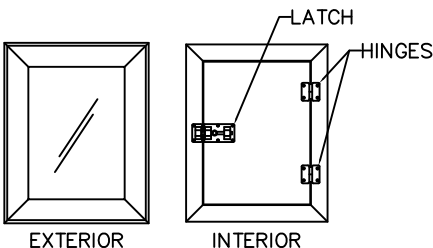

SPEAKEASY (NO GRILLE)

Hardware Finish Options: Dark Patina, Rust Patina
Material: Composite (Aluminum Hardware)

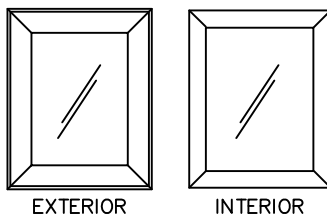

RECTANGLE DOOR LIGHT

Hardware Finish Options: n/a
Material: Composite
Available with All Speakeasy Grilles

INSULATED GLASS

- Clear Safety
- Clear Beveled
- Glue Chip
- Low-E
- Rain
- Frosted

TRIPLE GLAZED

A

"A" GLASS

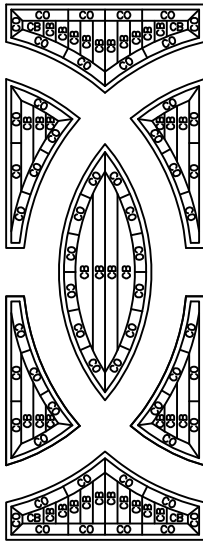

LEGEND
 CB-Clear Bevel
 CO-Cotswald

Door Size 12"-14"
Glass Size 7 1/8"

15"-18"
 9 1/8"

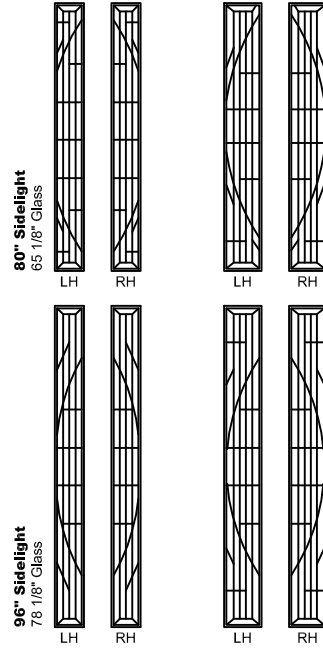

Door Size
Glass Size

30"
 Various

32"
 Various

36"
 Various

42"
 Various

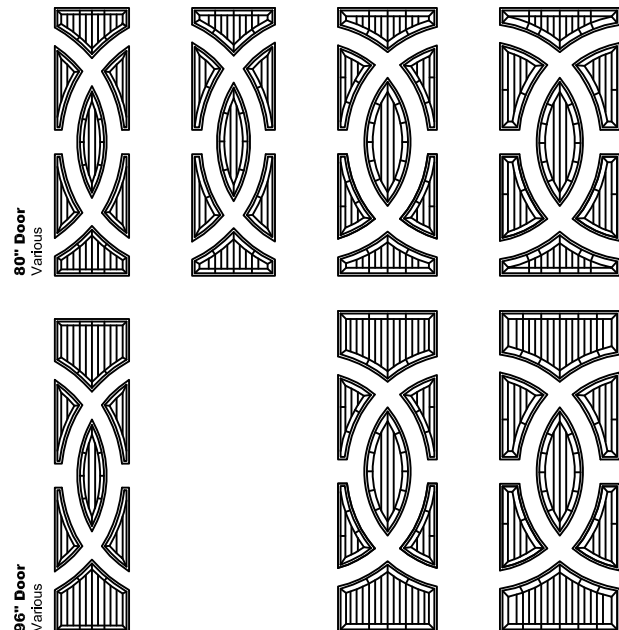

INSULATED GLASS

Clear Safety
Clear Beveled
Glue Chip
Low-E
Rain
Reed
Frosted

TRIPLE GLAZED

ND - NV - NT - Q

"Q" GLASS

Door Size
Glass Size

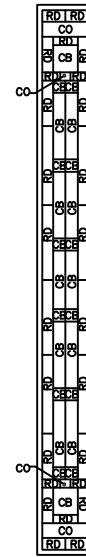

LEGEND
CB-Clear Bevel
CO-Cotswald
RD-Reed

12"-15"
6 7/8"



80"/84" Door
66 7/8" Glass

16"-18"
10 7/8"

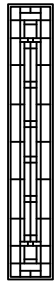

96" Door
82 7/8" Glass



"ND" GLASS

Door Size
Glass Size

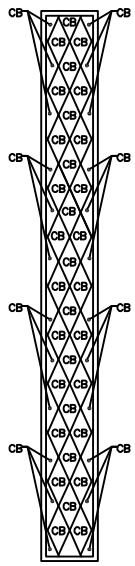

LEGEND
CB-Clear Bevel

12"-15"
6 7/8"



80"/84" Door
66 7/8" Glass

16"-18"
10 7/8"



96" Door
82 7/8" Glass



"NV" GLASS

Door Size
Glass Size

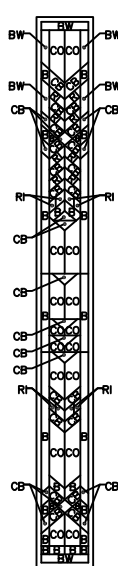

LEGEND
CB-Clear Bevel
CO-Cotswald
RI-Ripple
BW-Antique Brown
B-Blue

12"-15"
6 7/8"



80"/84" Door
66 7/8" Glass

16"-18"
10 7/8"



96" Door
82 7/8" Glass



"NT" GLASS

Door Size
Glass Size

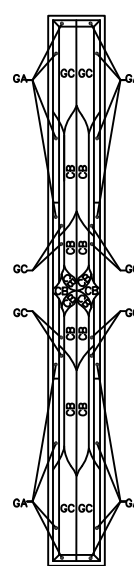

LEGEND
CB-Clear Bevel
GC-Glue Chip
GA-Clear Gotta

12"-15"
6 7/8"



80"/84" Door
66 7/8" Glass

16"-18"
10 7/8"

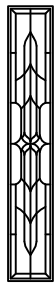

96" Door
82 7/8" Glass



INSULATED GLASS

Clear Safety
Clear Beveled
Glue Chip
Low-E
Rain
Reed
Frosted

TRIPLE GLAZED

ND - NV - NT
Q - X - Z

"ND" GLASS

Door Size
Glass Size

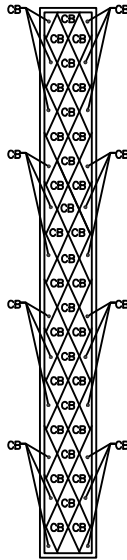

LEGEND
CB-Clear Bevel

12"-15"
6 7/8"



80"/84" Door
66 7/8" Glass



96" Door
82 7/8" Glass

16"-18"
10 7/8"



"NT" GLASS

Door Size
Glass Size

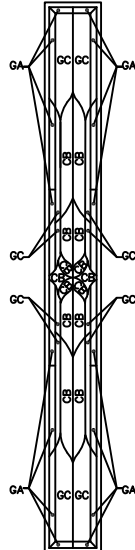

LEGEND
CB-Clear Bevel
GC-Glue Chip
GA-Clear Gotta

12"-15"
6 7/8"



80"/84" Door
66 7/8" Glass



96" Door
82 7/8" Glass

16"-18"
10 7/8"



"NV" GLASS

Door Size
Glass Size

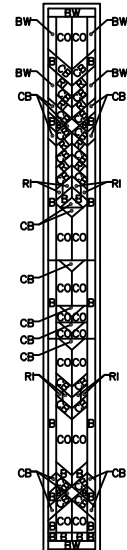

LEGEND
CB-Clear Bevel
CO-Cotswald
RI-Ripple
BW-Antique Brown
B-Blue

12"-15"
6 7/8"



80"/84" Door
66 7/8" Glass



96" Door
82 7/8" Glass

16"-18"
10 7/8"



"Q" GLASS

Door Size
Glass Size

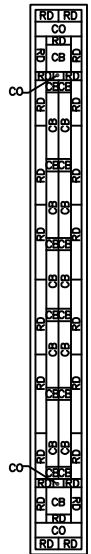

LEGEND
CB-Clear Bevel
CO-Cotswald
RD-Reed

12"-15"
6 7/8"



80"/84" Door
66 7/8" Glass



96" Door
82 7/8" Glass

16"-18"
10 7/8"

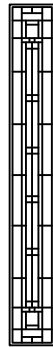

"X" GLASS

Door Size
Glass Size

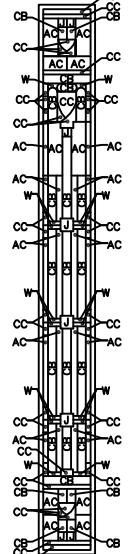

LEGEND
CB-Clear Bevel
AC-Clear Antique
CC-Clear Crackle
IG-Iridescent Gotta
W-Wispy White
J-Jewel

12"-15"
6 7/8"



80"/84" Door
66 7/8" Glass



96" Door
82 7/8" Glass

16"-18"
10 7/8"



"Z" GLASS

Door Size
Glass Size

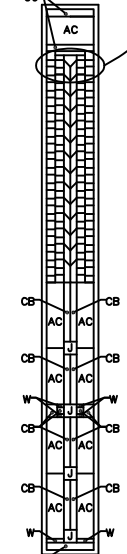

LEGEND
CB-Clear Bevel
AC-Clear Antique
CC-Clear Crackle
W-Wispy White
J-Jewel

12"-15"
6 7/8"



80"/84" Door
66 7/8" Glass



96" Door
82 7/8" Glass

16"-18"
10 7/8"

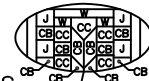



DECORATIVE GRILLES A1101 SIDELIGHT

Scale: 3/16" = 1'-0"

GRILLE NOTES

Finish: Dark Patina
Material: Aluminum

- To Match Aurora Estate Series Doors (Flat Top)
- Grilles Are Fixed (Non-Operable)
- Design may Vary by Size/Shape (16" x 96" Shown)
- Surface Mounted to Stiles
- Grilles May be Customized



BORDEAUX



RUSTIC



SEVILLE



TUSCANY

GRILLE NOTES

Finish: Dark Patina
Material: Aluminum

- Door & Sidelight Grilles are Operable
(Handed to Match Door)
- Design may Vary by Size/Shape of Door
(18"/36" x 96" Shown)
- Grilles May be Customized

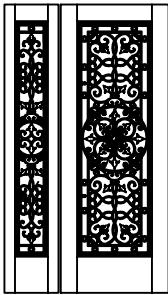

ARMADA

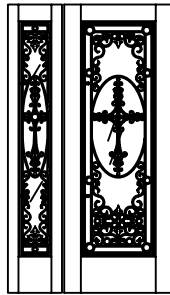

CATHEDRAL

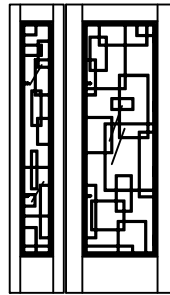

CENTURY

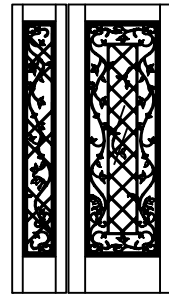

CHATEAU

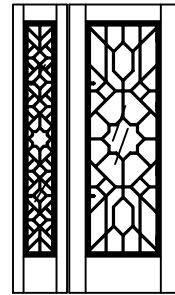

ETRUSCAN

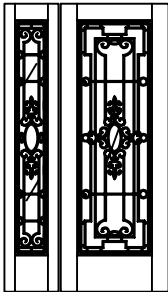

GEORGIAN

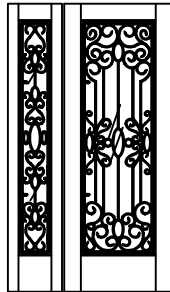

HERITAGE

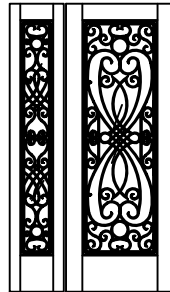

INFINITY

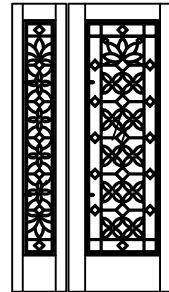

LOTUS

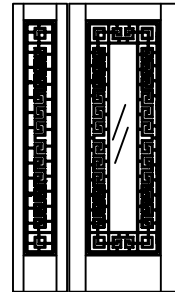

MEANDER

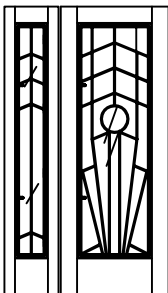

METROPOLIS

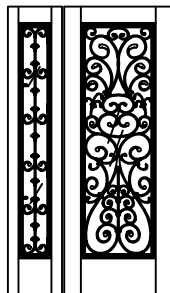

MONTE CARLO

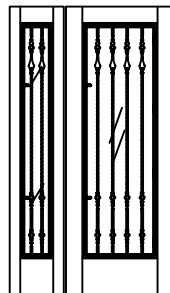

REGAL

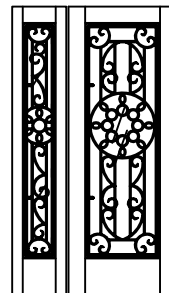

SUNDIAL

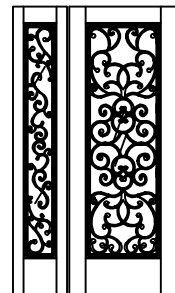

VERSAILLES

A252
CROSS SECTIONS

Scale: 3" = 1'-0"

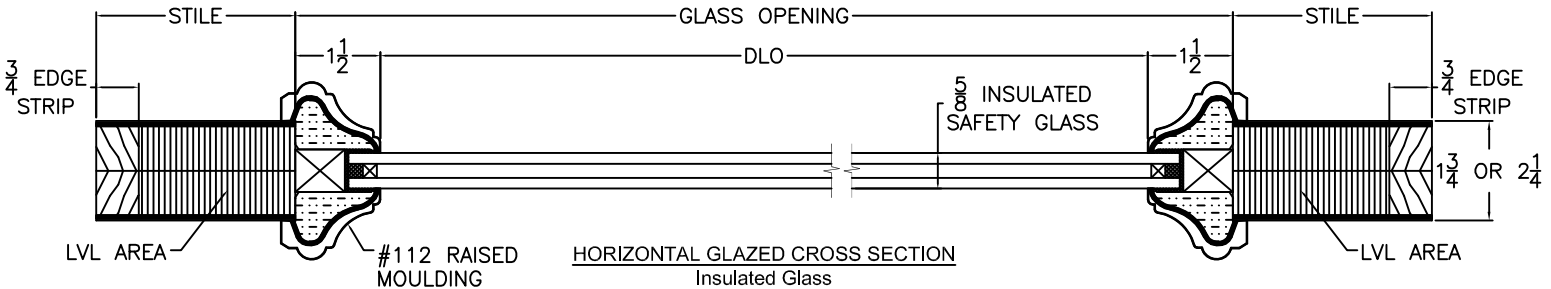
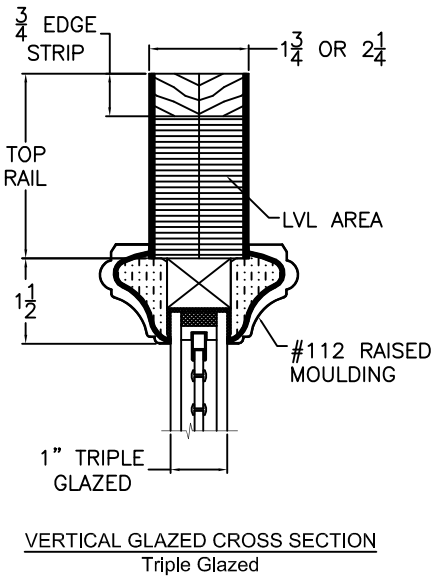
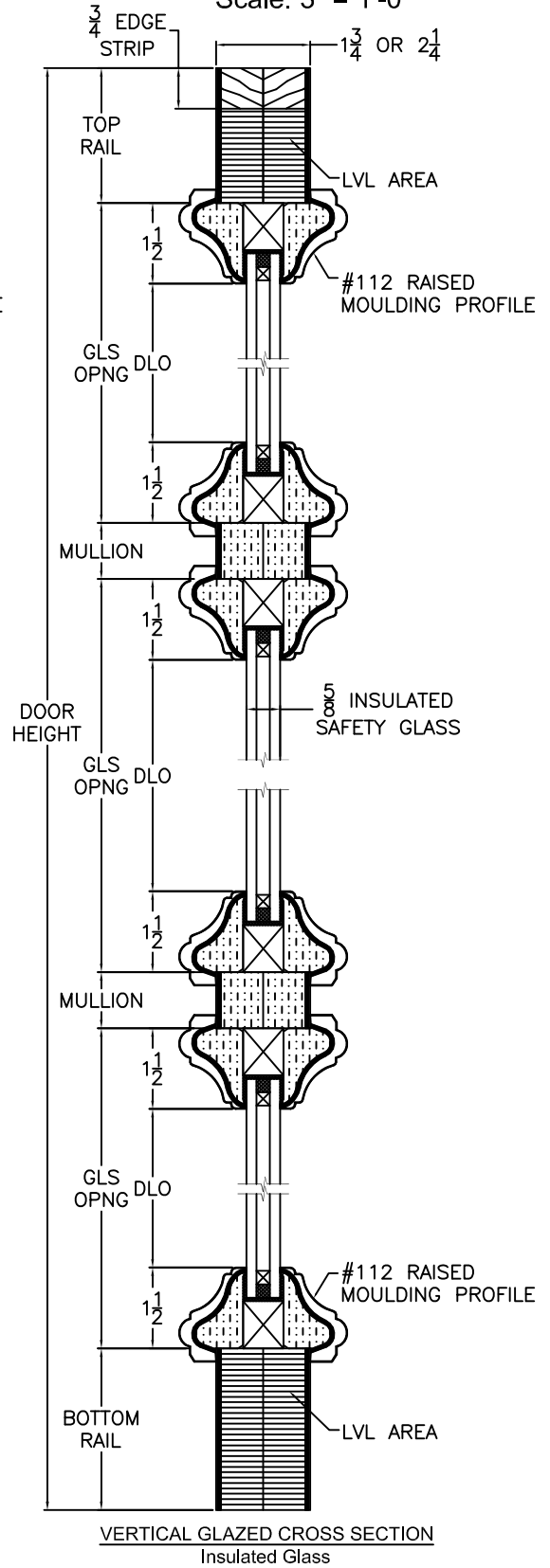
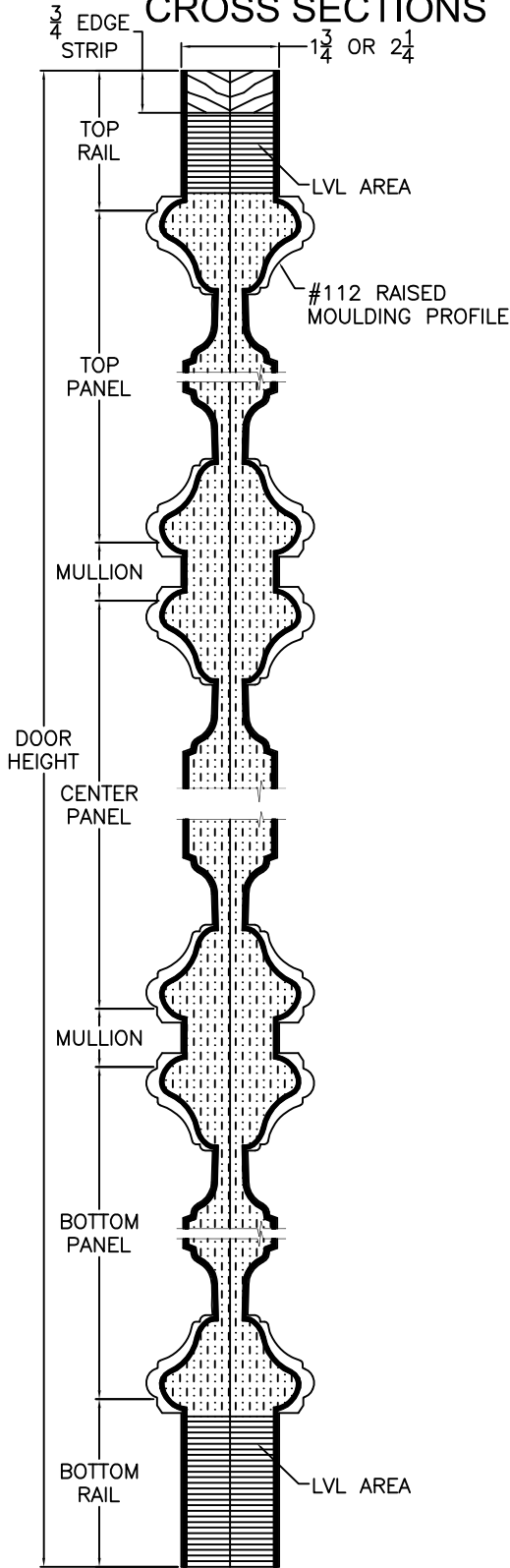
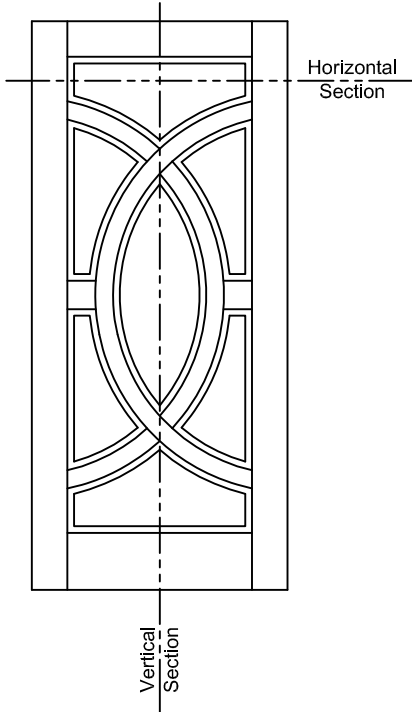

**A5001
CROSS SECTIONS**

Scale: 3" = 1'-0"

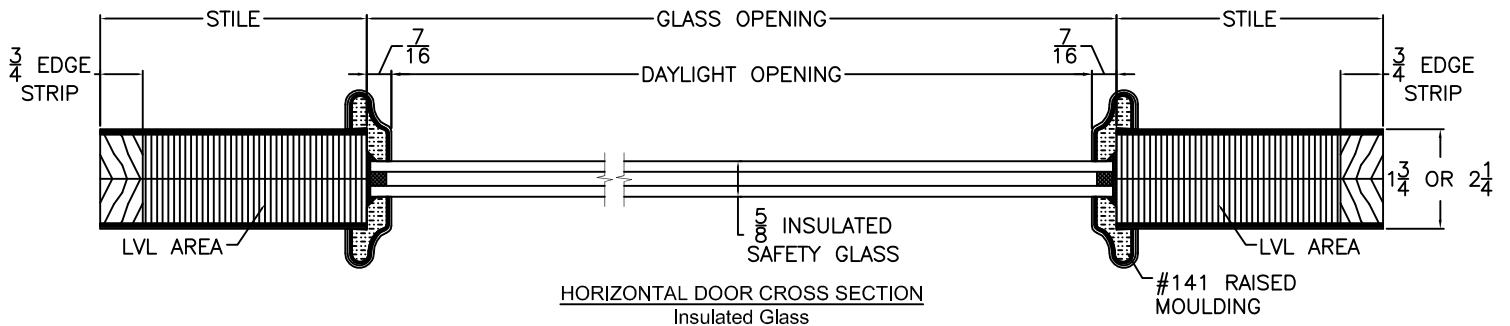
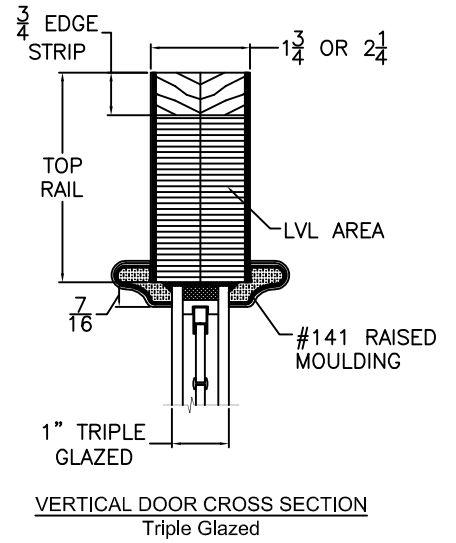
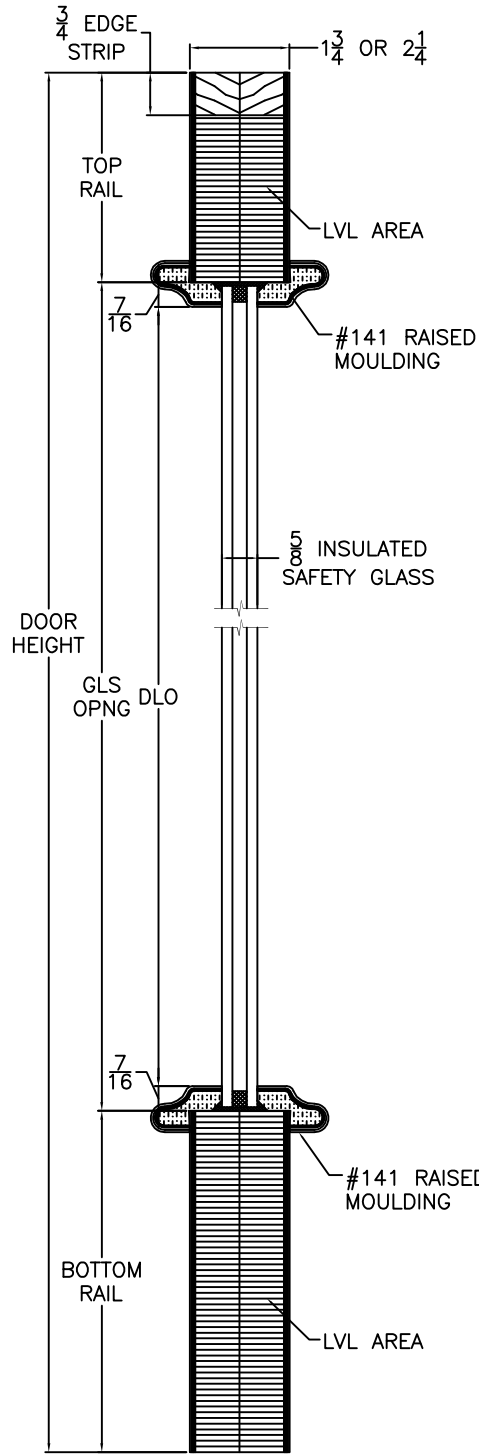
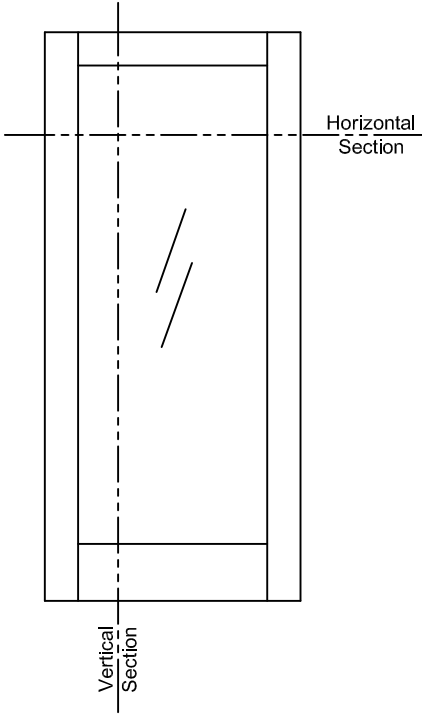

A5009 CROSS SECTIONS

Scale: 3" = 1'-0"
Rev. 0 07/24/09

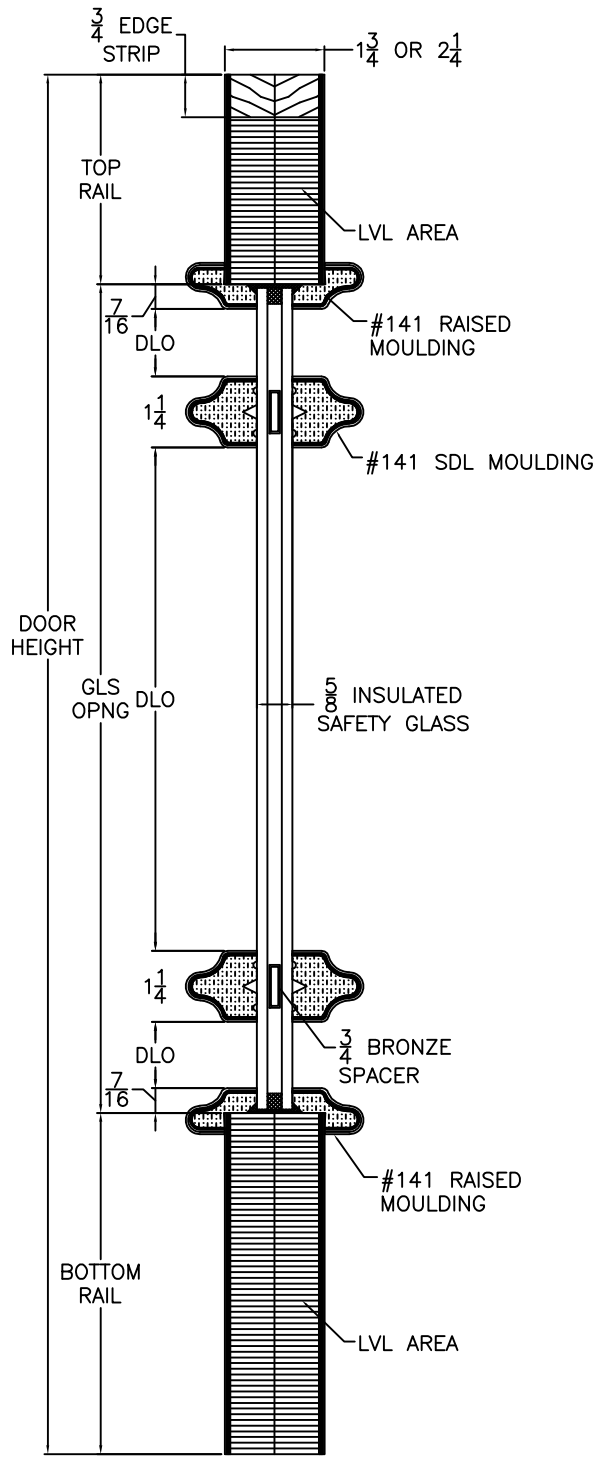
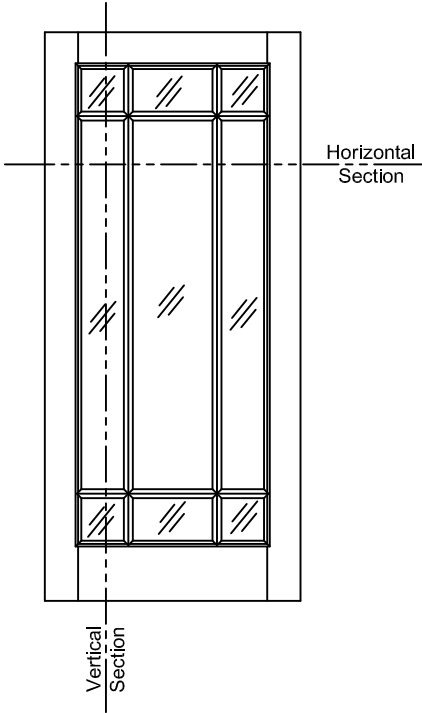

VERTICAL DOOR CROSS SECTION
Insulated Glass

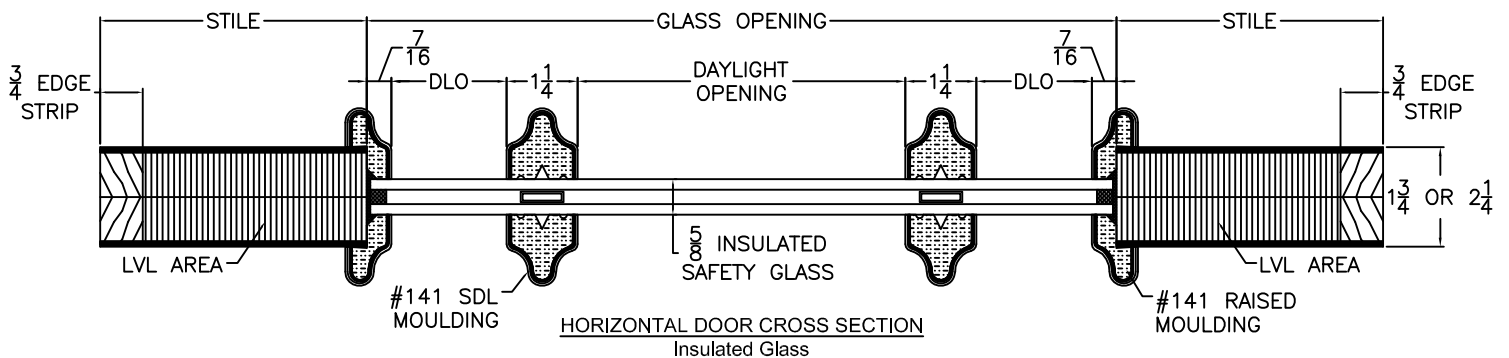

A5010 CROSS SECTIONS

Scale: 3" = 1'-0"

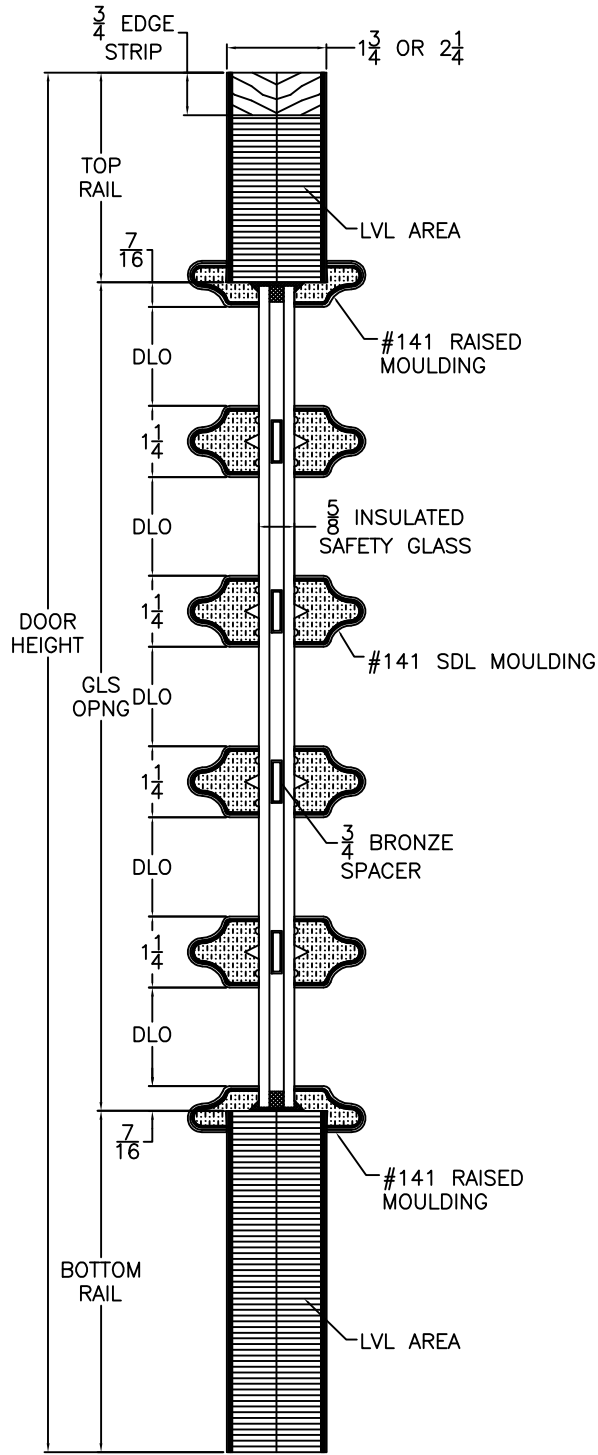
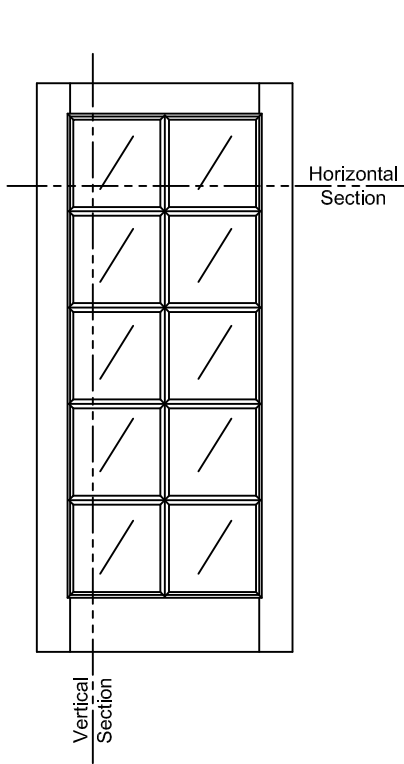

VERTICAL DOOR CROSS SECTION
Insulated Glass

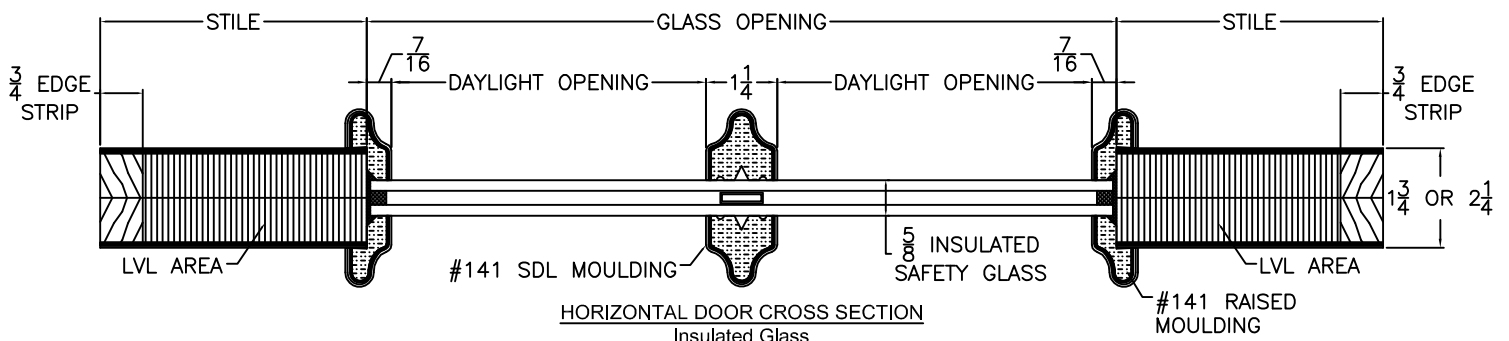

HORIZONTAL DOOR CROSS SECTION
Insulated Glass

A5012 CROSS SECTIONS

Scale: 3" = 1'-0"

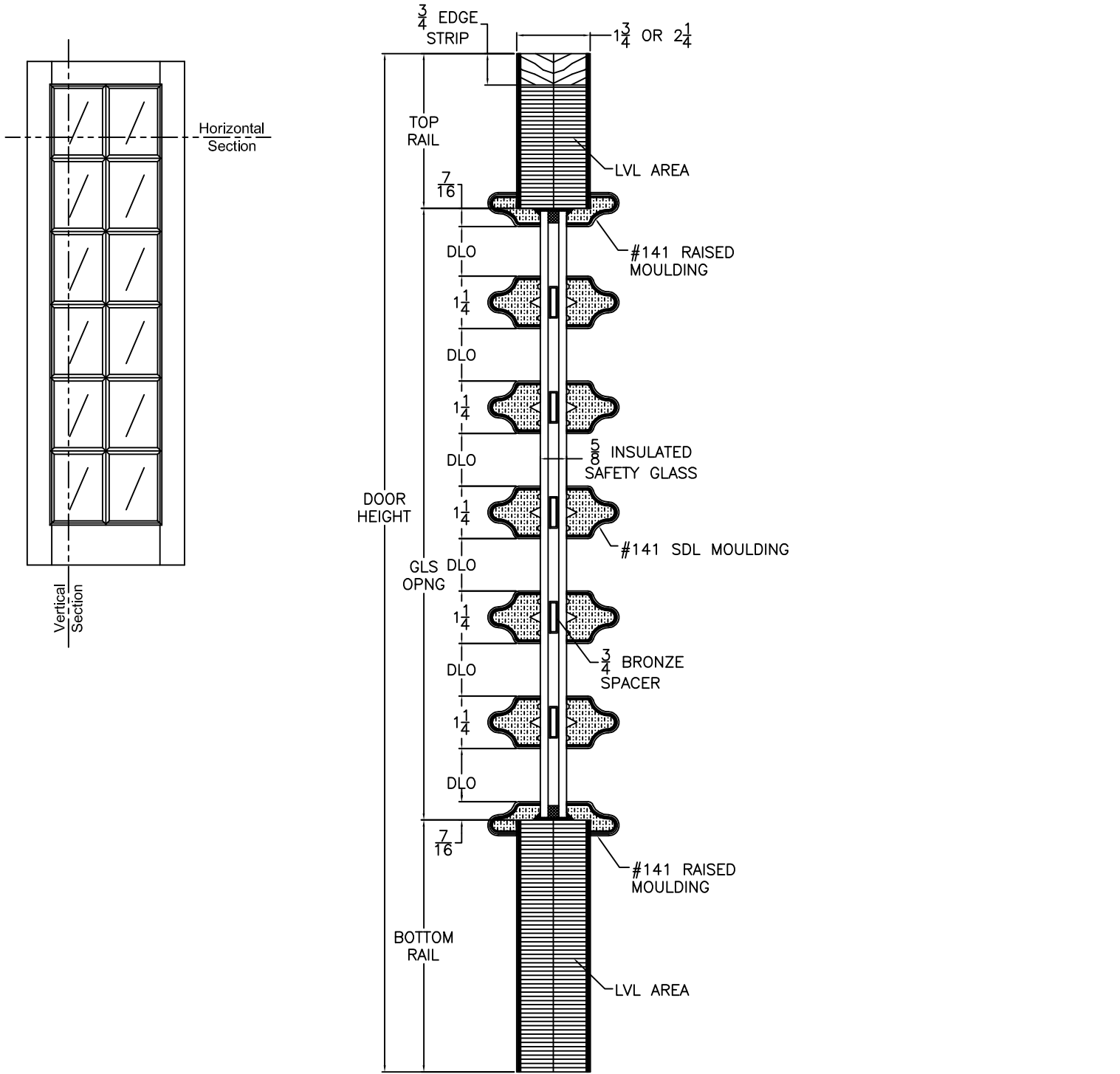

VERTICAL DOOR CROSS SECTION
Insulated Glass

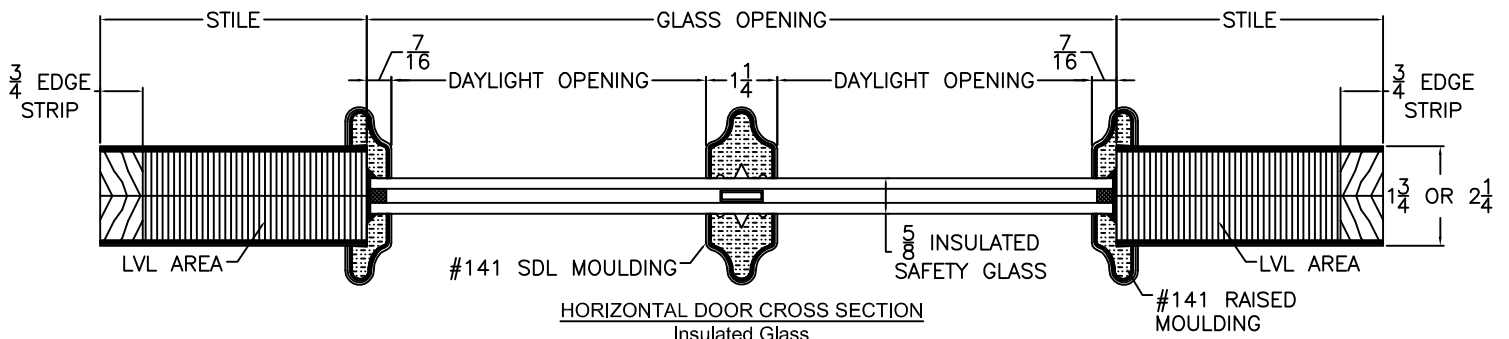

HORIZONTAL DOOR CROSS SECTION
Insulated Glass

A5015
CROSS SECTIONS

Scale: 3" = 1'-0"

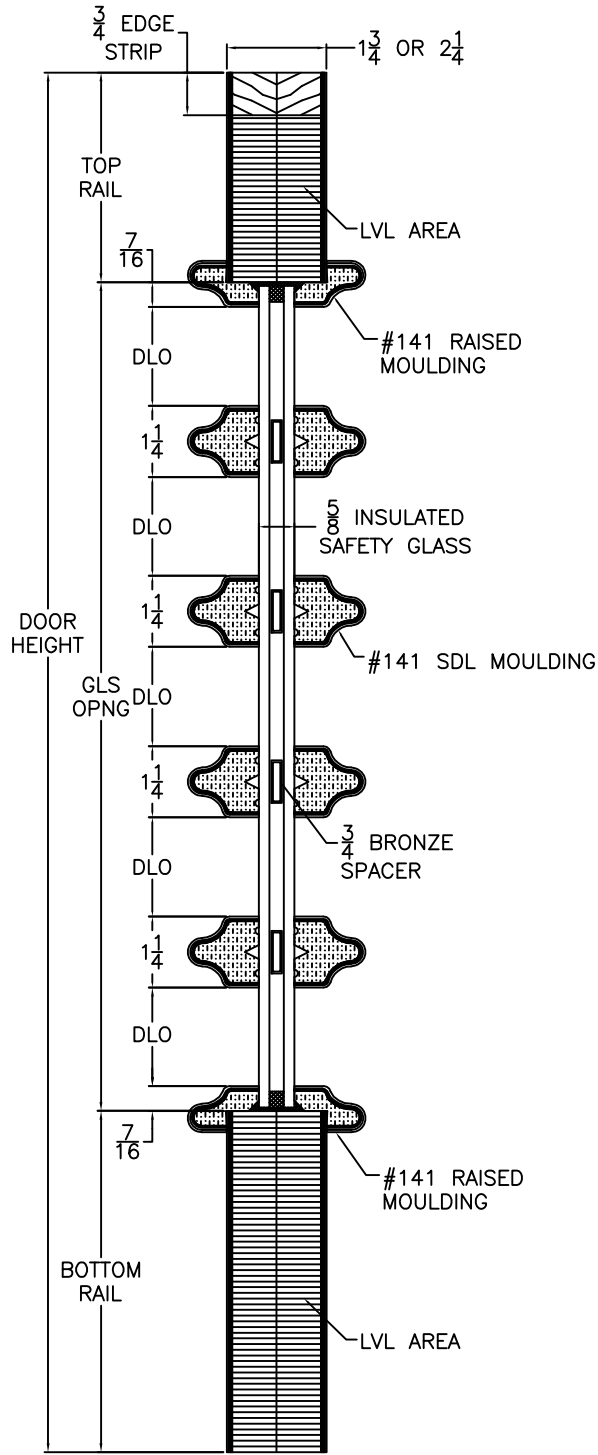
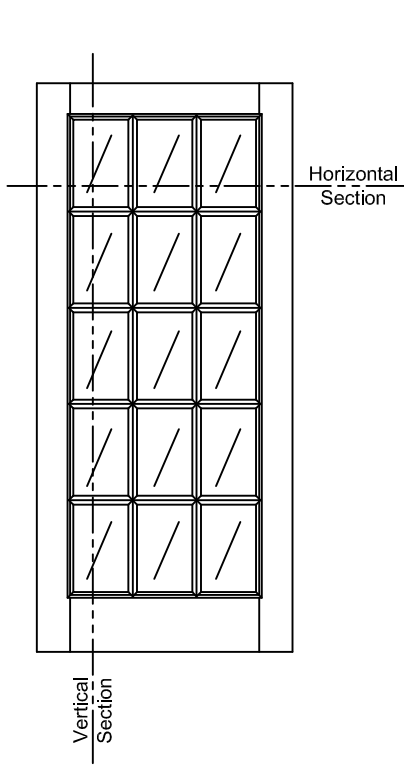

VERTICAL DOOR CROSS SECTION
Insulated Glass

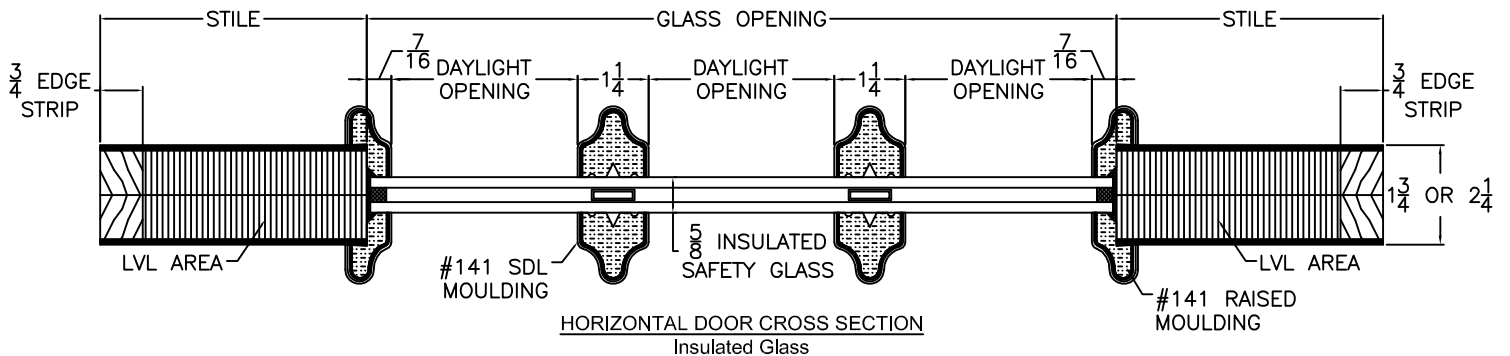

HORIZONTAL DOOR CROSS SECTION
Insulated Glass

A5037 CROSS SECTIONS

Scale: 3" = 1'-0"

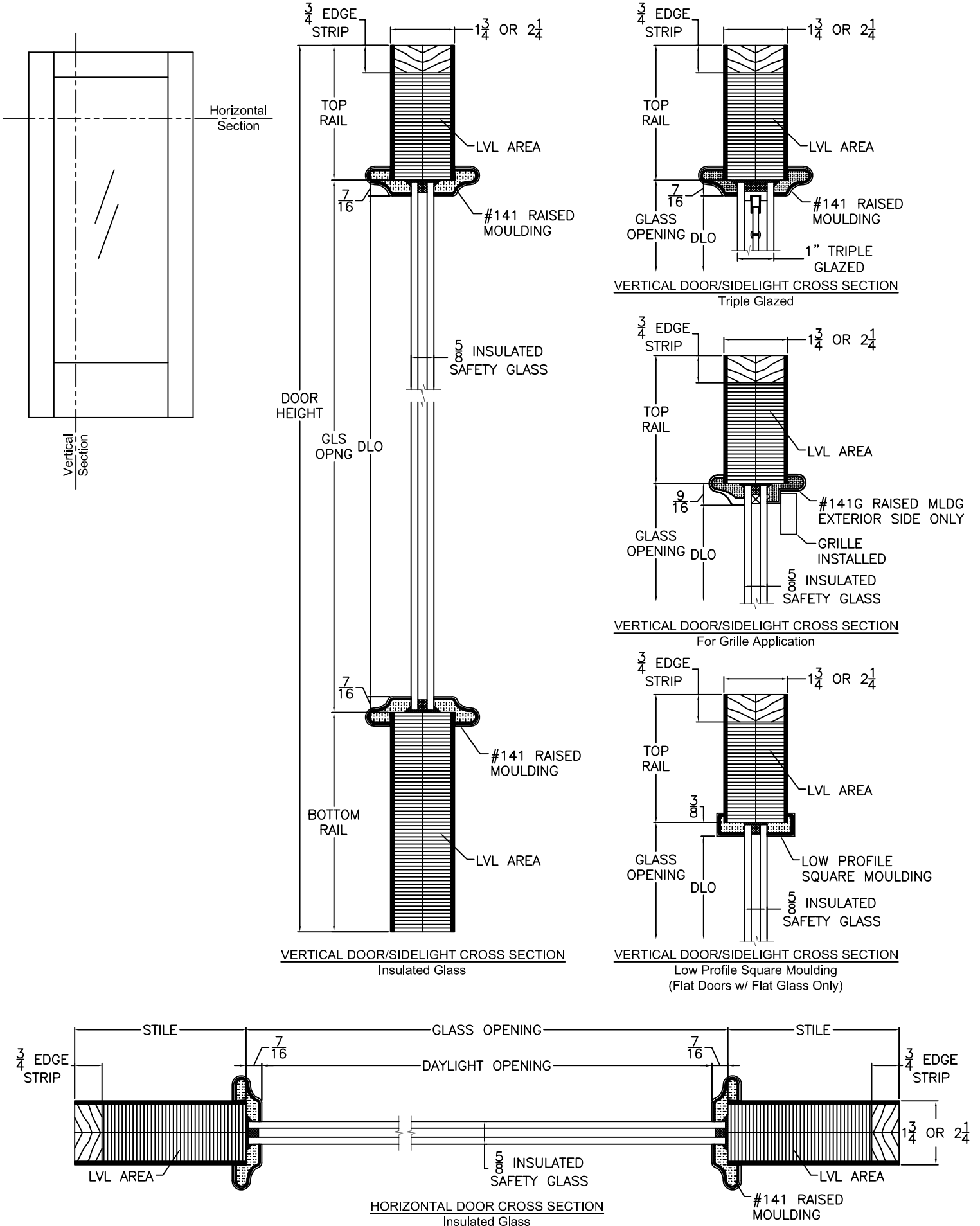

A1101
CROSS SECTIONS

Scale: 3" = 1'-0"

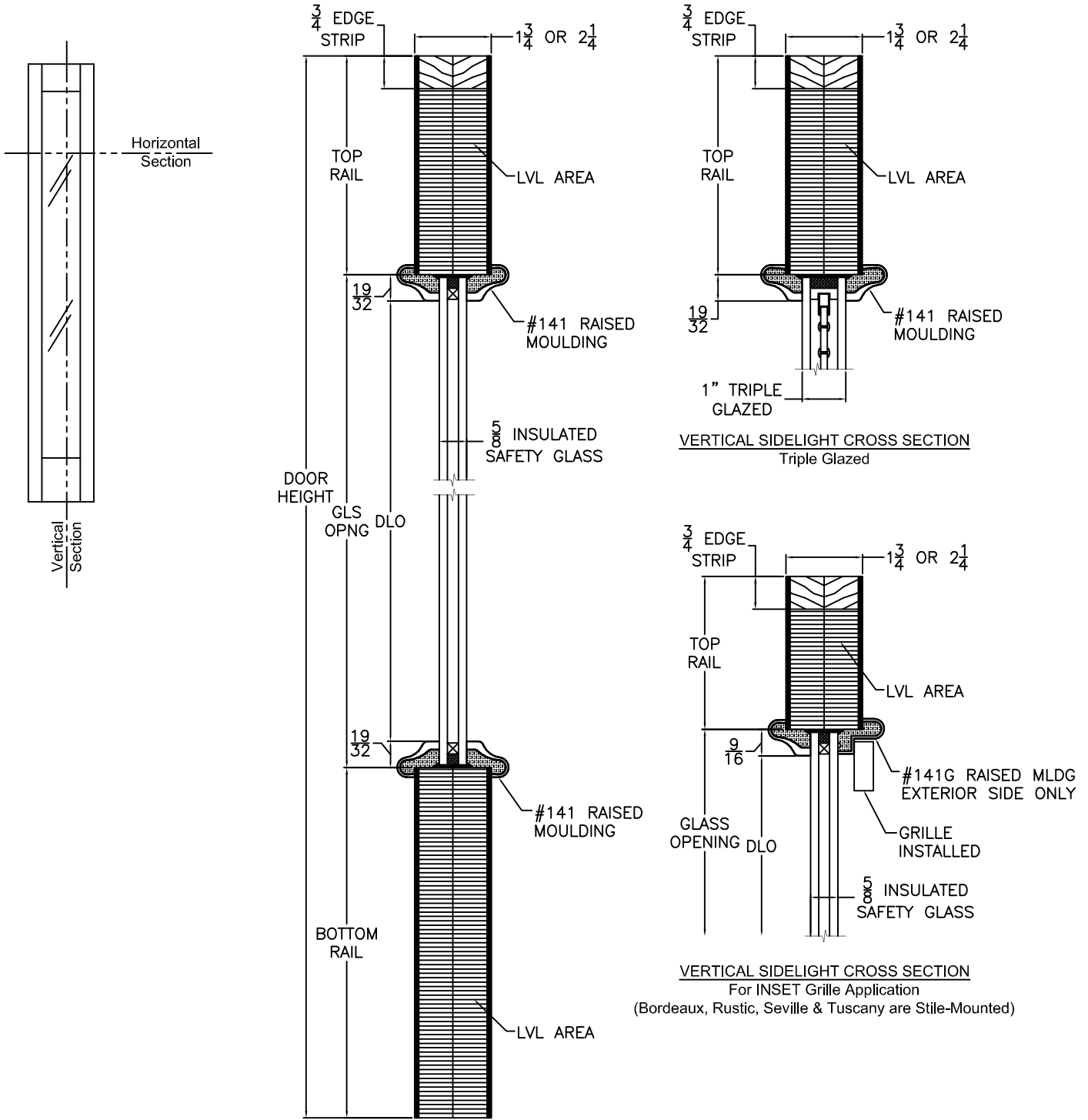

VERTICAL SIDELIGHT CROSS SECTION
Triple Glazed

VERTICAL SIDELIGHT CROSS SECTION
For INSET Grille Application
(Bordeaux, Rustic, Seville & Tuscany are Stile-Mounted)

VERTICAL SIDELIGHT CROSS SECTION
Insulated Glass

HORIZONTAL SIDELIGHT CROSS SECTION
Insulated Glass

A1103 CROSS SECTIONS

Scale: 3" = 1'-0"

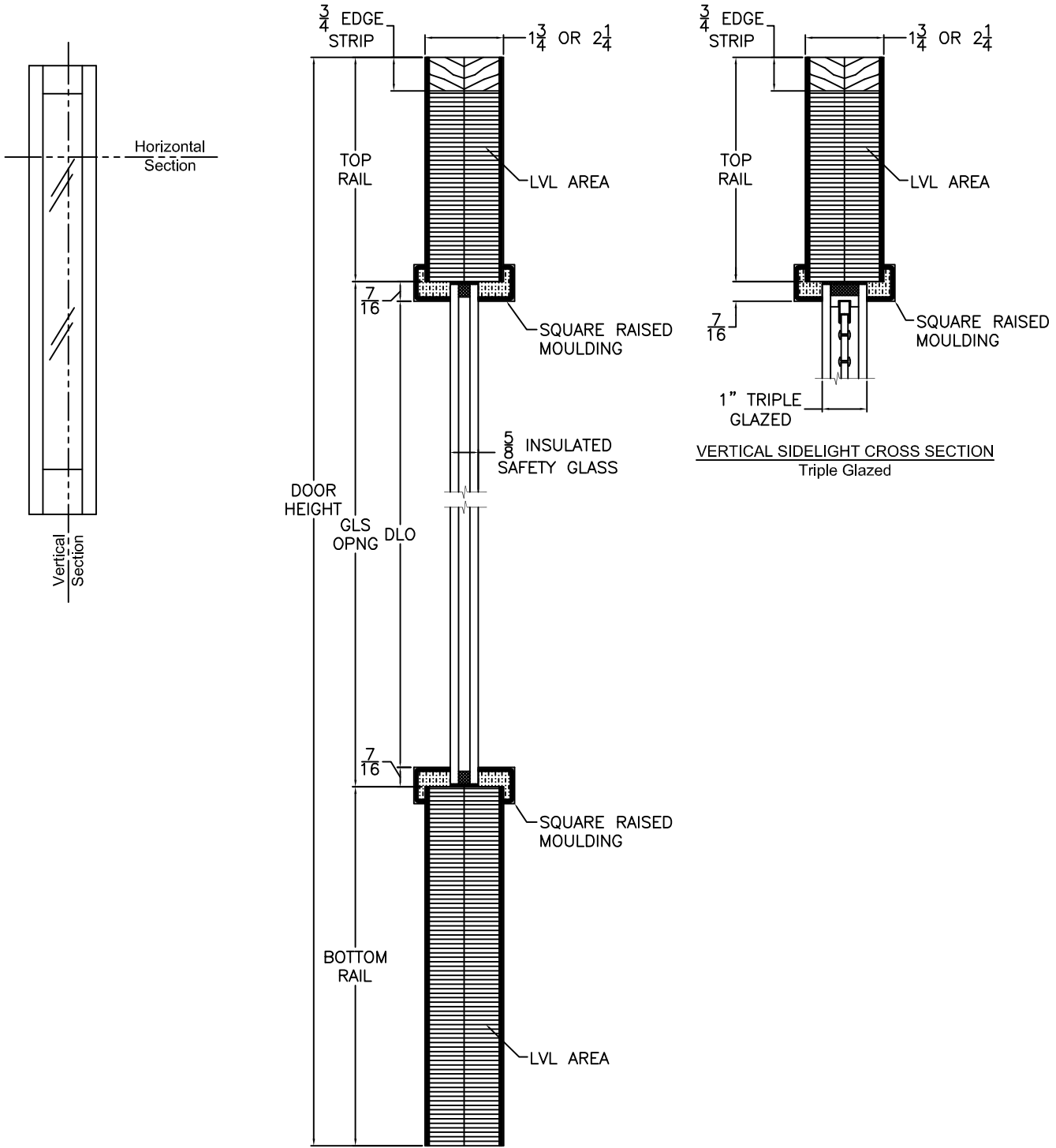

VERTICAL SIDELIGHT CROSS SECTION
Insulated Glass

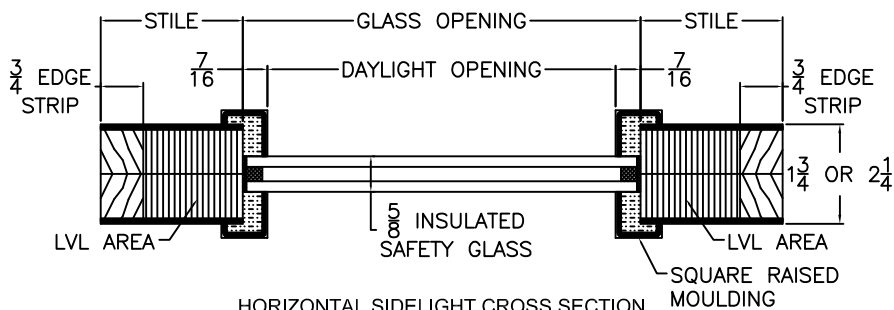

HORIZONTAL SIDELIGHT CROSS SECTION
Insulated Glass

A5701
CROSS SECTIONS

Scale: 3" = 1'-0"

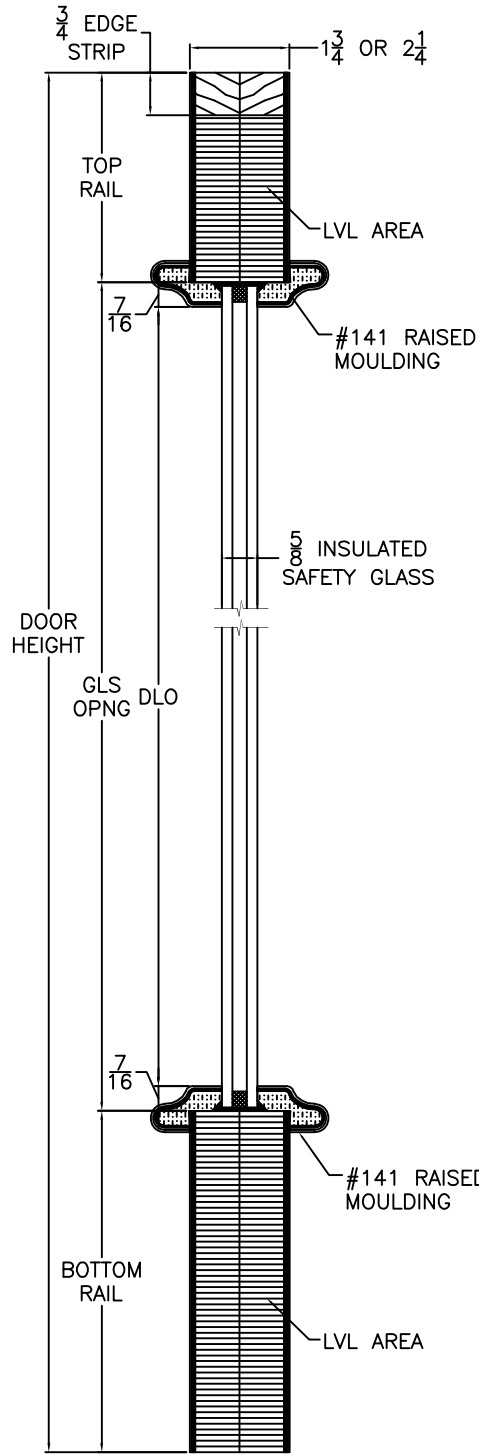
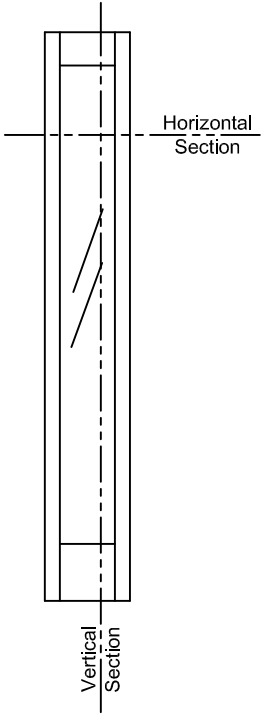

VERTICAL SIDELIGHT CROSS SECTION
Insulated Glass

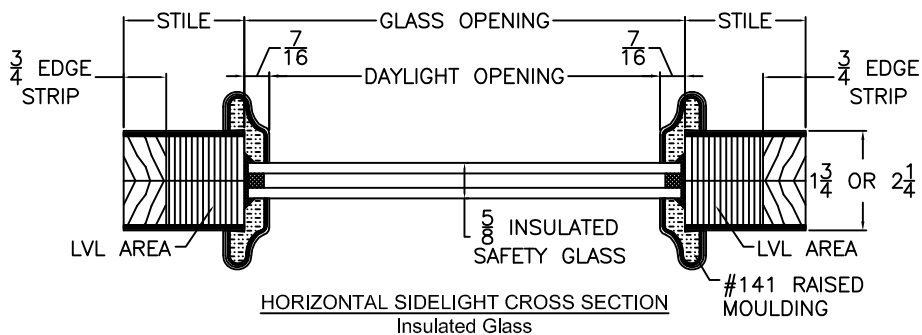
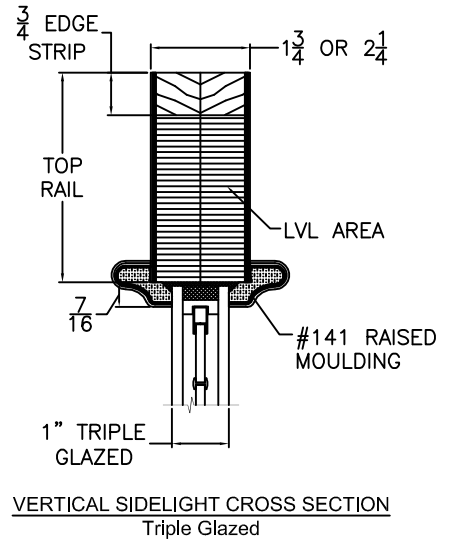

A5705
CROSS SECTIONS

Scale: 3" = 1'-0"

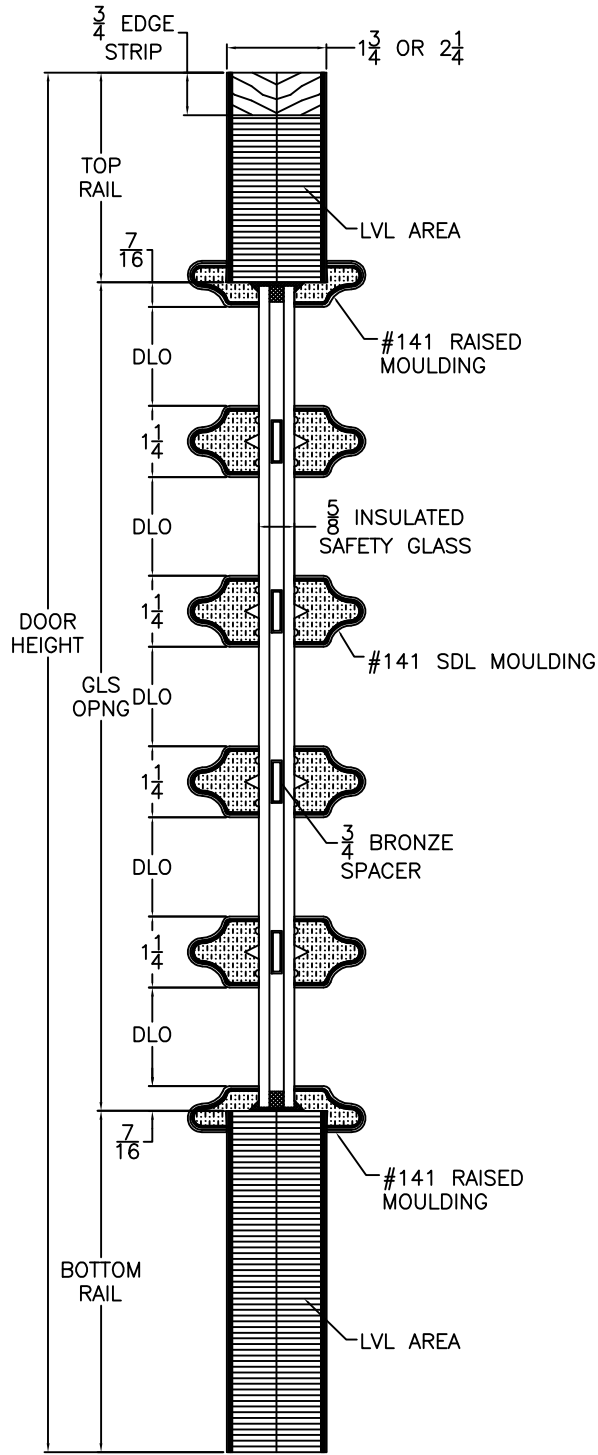
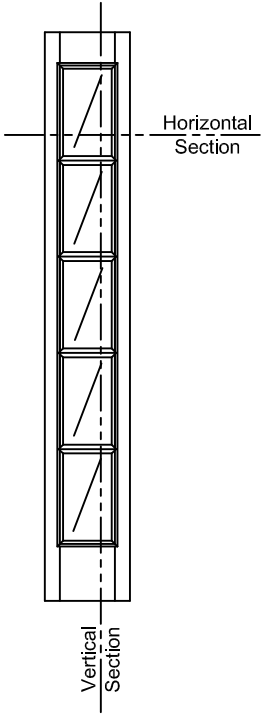

VERTICAL SIDELIGHT CROSS SECTION
Insulated Glass

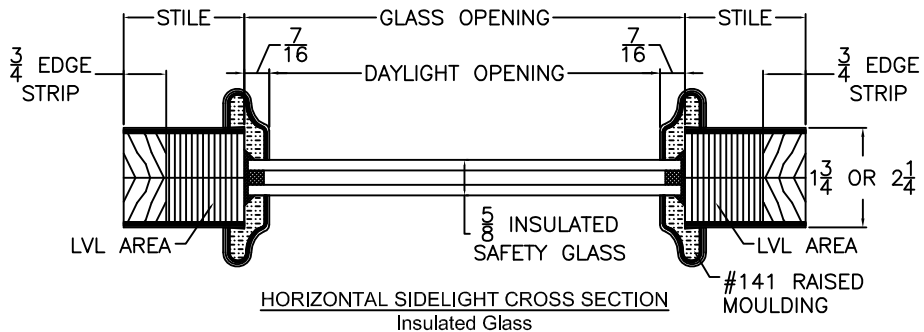

HORIZONTAL SIDELIGHT CROSS SECTION
Insulated Glass