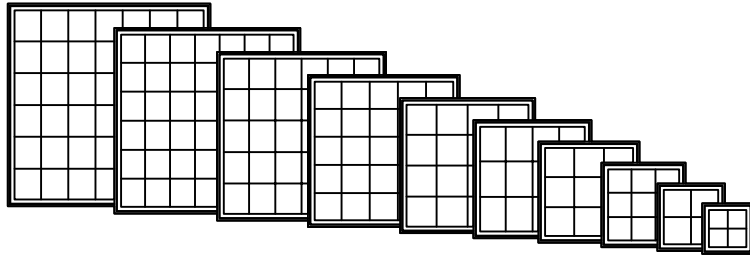

TABLE OF CONTENTS

Table of Contents.	1-1
General Information.	1-2
Grille & SDL Patterns.	1-3
Casement Handling & Operation.	1-4
Unit Sizing, Rough Opening & Masonry Openings	1-5
Trim Options	1-6
Jamb Options	1-8
Mullion Details & Specialty Trim	1-10
Glazing Options	1-15
Elevation Notes	1-21
General Sector Top Information	1-22
Sector Top Casement Handling & Operation	1-23
Sector Top Elevation Notes	1-24
Section Details: 6" Scale.	1-25
Bays & Bows Opening Specifications	1-39
Section Details: Bays & Bows-6" Scale.	1-45

GENERAL INFORMATION
CASEMENT



DIMENSIONAL WINDOWS

Clad casement windows may be specified as "dimensional", by adjusting the desired rough opening width or height in 1/16" increments from standard.

Clad casement windows are available with left or right hand operation, or stationary (non-venting). Operating mechanism includes corrosion resistant steel hinges and dual arm roto-type operator with hardened steel gears and operating arms. Sash locks are concealed unison type with an exposed locking lever and escutcheon plate. There are several interior hardware finish options. Refer to the Specifications for finish options.

MULTIPLE ASSEMBLIES

Clad casement windows may be mullered above, below, or beside other clad casement windows, or other clad window products. Factory assembled mulls are limited in height (100"), width (150"), and a total area (75 square feet).

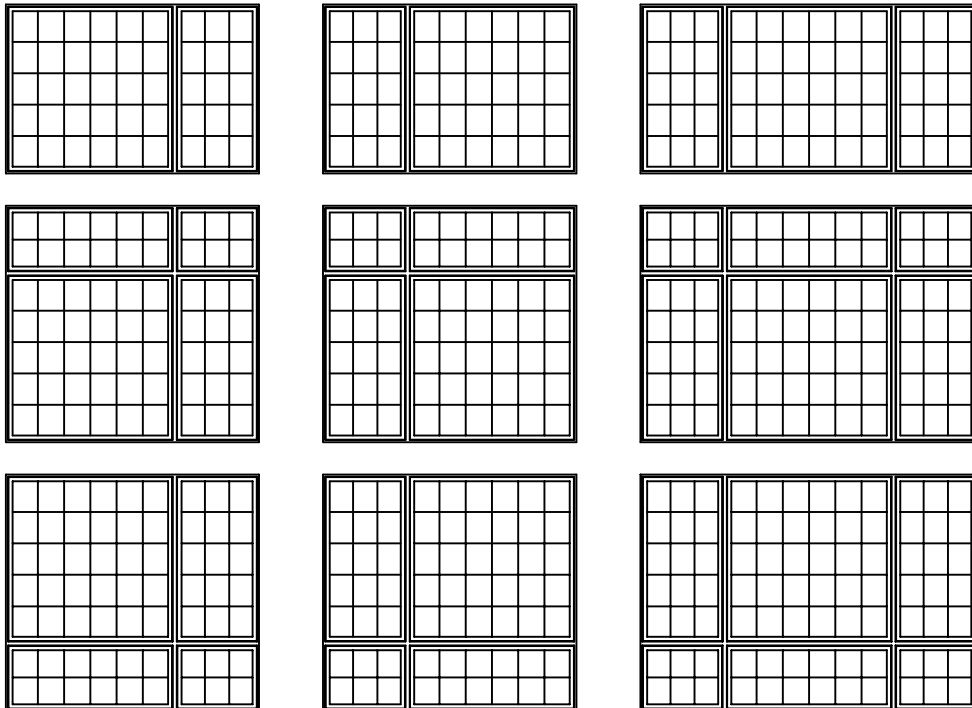

LITE CUT INFORMATION

Clad casement windows are available with removable grilles in 7/8", 1-1/8" and 1-3/8" widths, Airspace (between the panes) grilles, and Simulated Divided Lites. Standard lite cuts are rectangular, and conform to the layouts noted in the charts on the next page. To use the chart, refer to the appropriate table by the type of window and type of bars or grilles the section drawings illustrate. Then simply cross reference the frame Height and Width to determine the standard lite cut.

LITE CUT OPTIONS

Special lite cut patterns can include a wide variety of straight line and radius patterns. The illustrations shown here represent just a few of the possibilities. Rectangular, horizontal, vertical and Prairie lite patterns are available in all standard size clad casement windows. Uneven, diamond, radius and Gothic lite cuts are available, subject to approval. Approvals are based on the ability to fulfill the design requirement while maintaining the construction integrity of the finished product.

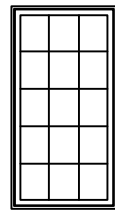

RECTANGULAR

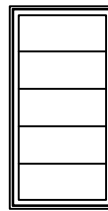

HORIZONTAL

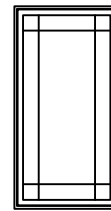

PRAIRIE

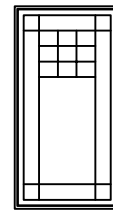

UNEVEN

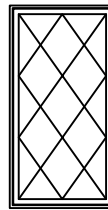

DIAMOND

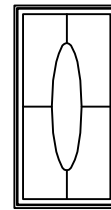

RADIUS

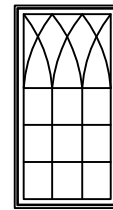

GOthic

BAR ALIGNMENT

Alignment of divided lite muntin bars from one window to the next is often required by fine architectural design. Wood grilles, Grilles Between the Glass, grilles, and Simulated Divided Lites may be specified with muntin bars aligned.

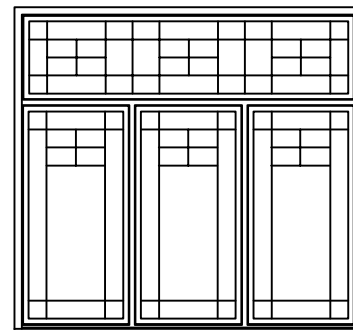

HANDLING & OPERATION
CASEMENT

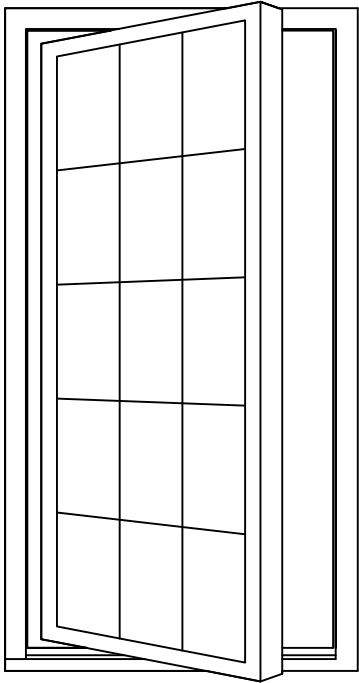

LEFT
HAND

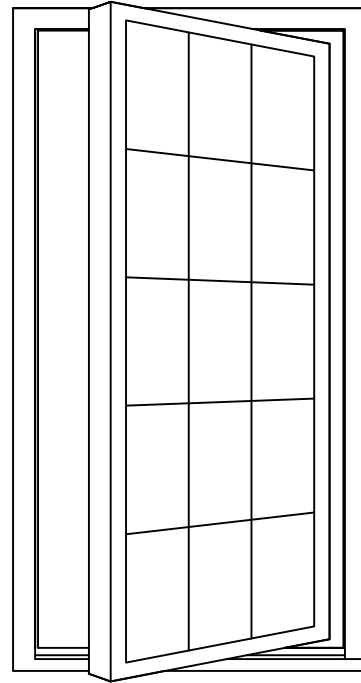

RIGHT
HAND

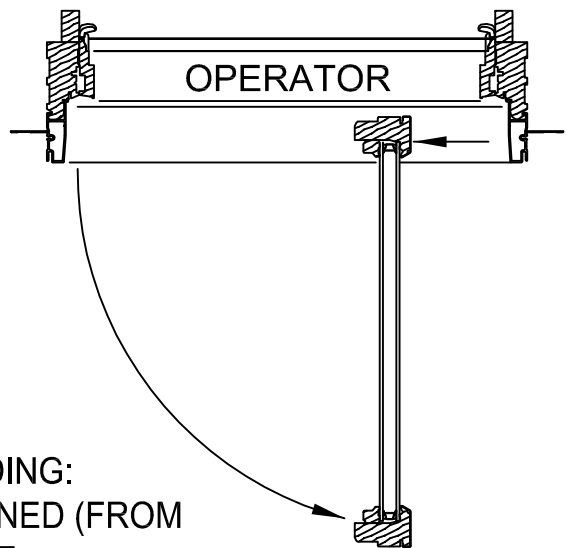
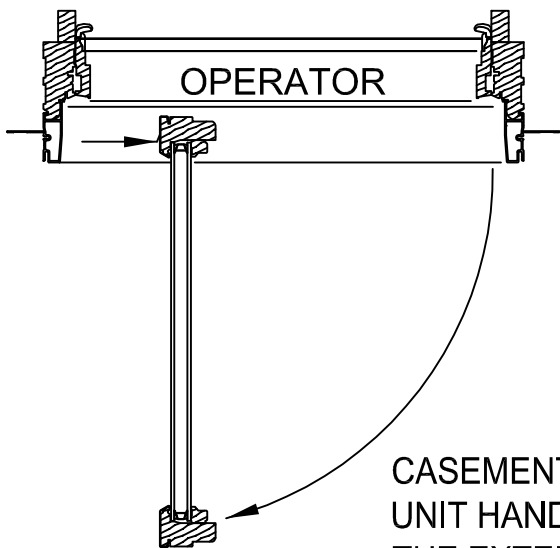

CASEMENT UNIT HANDING:
UNIT HANDING IS DEFINED (FROM
THE EXTERIOR) AS THE
DIRECTION THE SASH OPENS.

UNIT SIZING, ROUGH OPENINGS & MASONRY OPENINGS

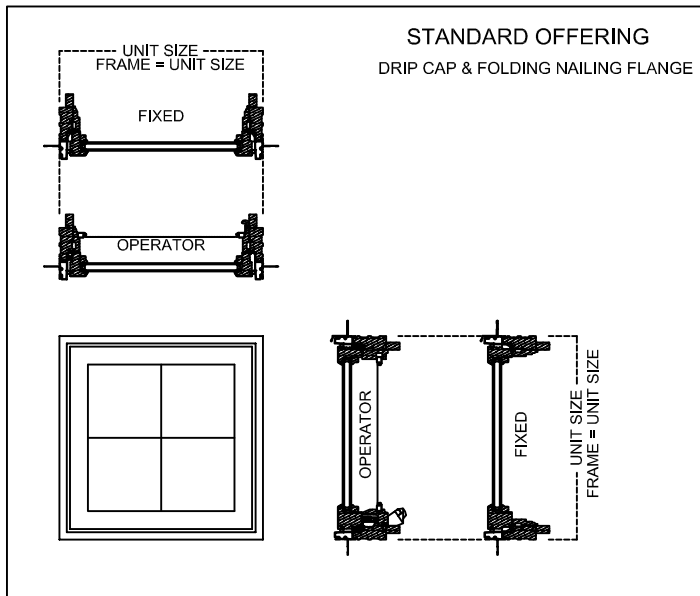

GENERAL NOTES:

UNITS WITH NO TRIM AND SILL NOSE:
UNIT SIZE = FRAME SIZE

UNIT SIZE IS ALWAYS THE
EXTREME SIZE OF THE WINDOW
WITH OR WITHOUT TRIM
(DRIP CAP & NAILING FLANGE ARE
NOT ADDED TO ANY UNIT SIZING)

MASONRY OPENING:

MASONRY OPENING IS ALWAYS 1/2" OVER
THE UNIT SIZE OF THE WINDOW

ROUGH OPENING:

ROUGH OPENING IS ALWAYS 3/4" OVER
FRAME SIZE OF THE WINDOW

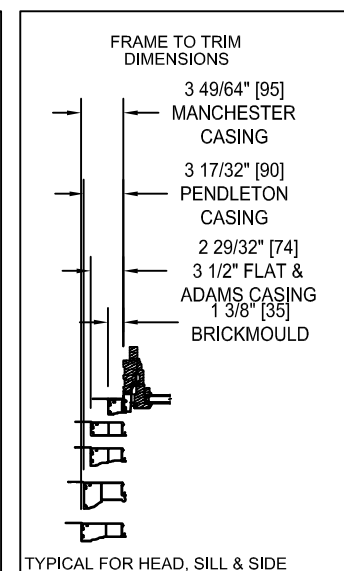
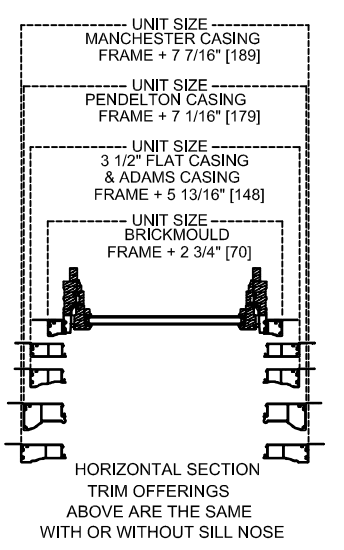
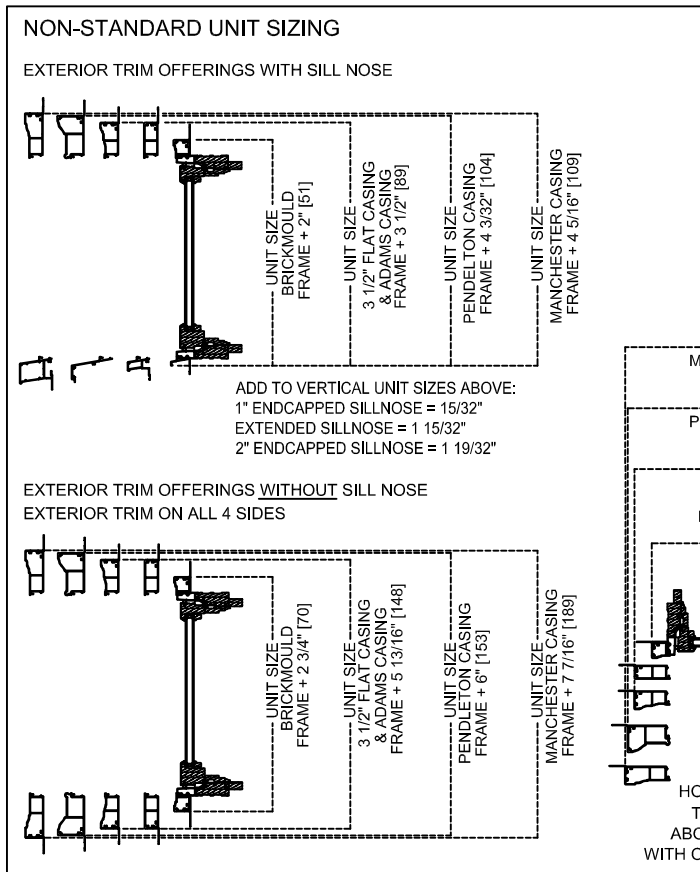
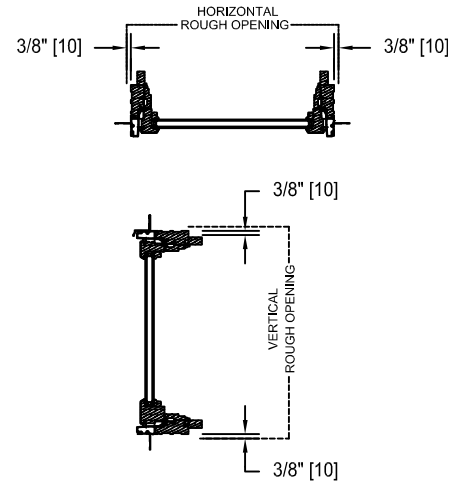

**TRIM OPTIONS
CASEMENT**

EXTERIOR TRIM

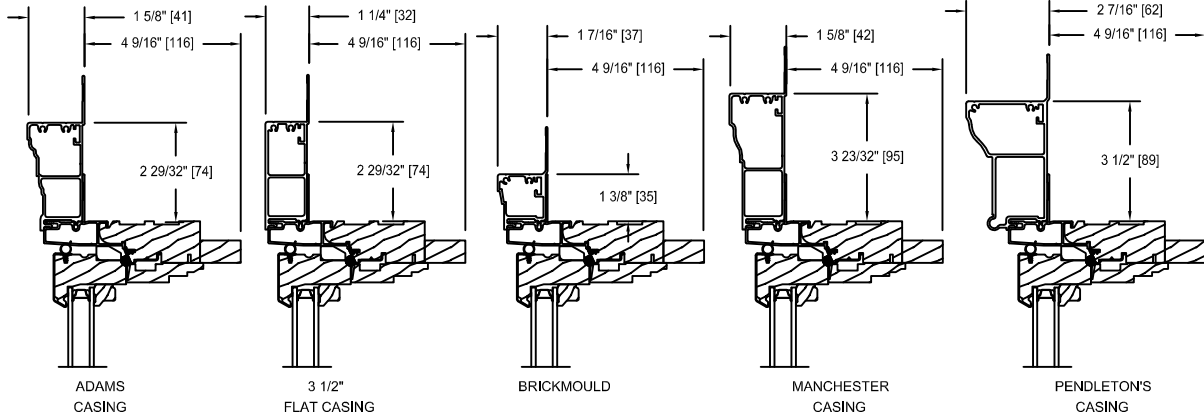

SILL NOSE OPTIONS

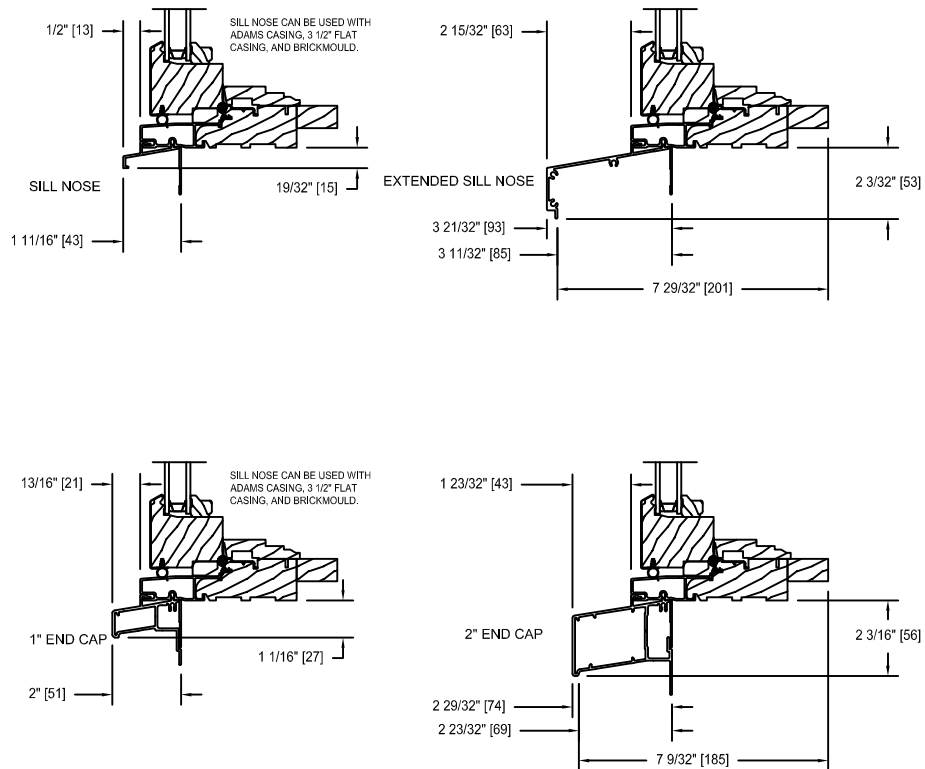

TRIM OPTIONS
SECTOR TOP RADIUS

EXTERIOR TRIM

TRIM OPTIONS NOTE:
JAMB EXTENDERS & SILL OPTIONS ARE
CONSISTENT WITH CUSTOM CLAD CASEMENT
(STRAIGHTLINE).

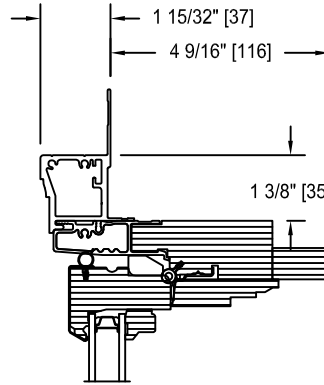

BRICKMOULD

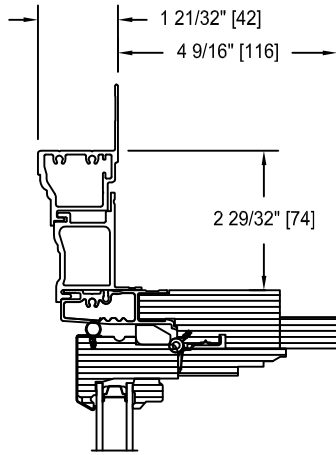

ADAMS
CASING

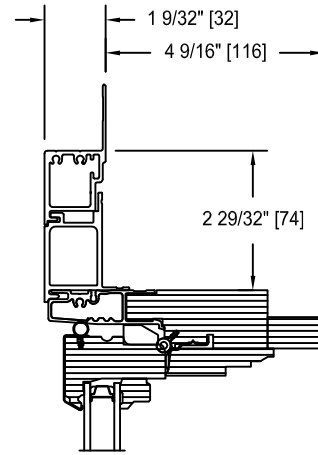

3 1/2"
FLAT CASING

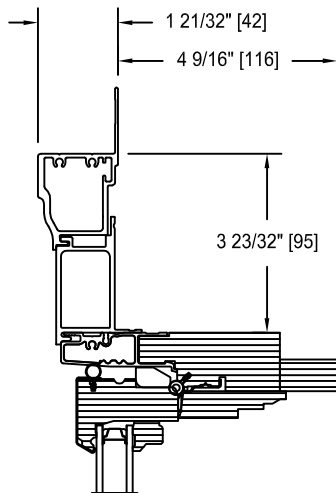

MANCHESTER
CASING

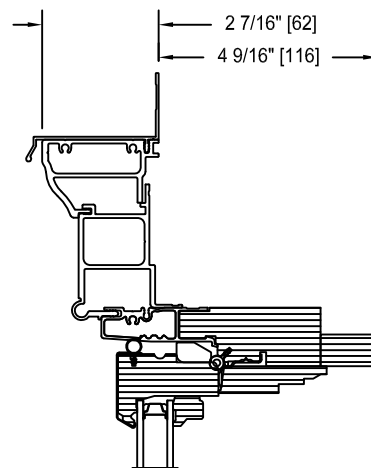

PENDLETON'S
CASING

JAMB EXTENDER OPTIONS

4 9/16" WALL

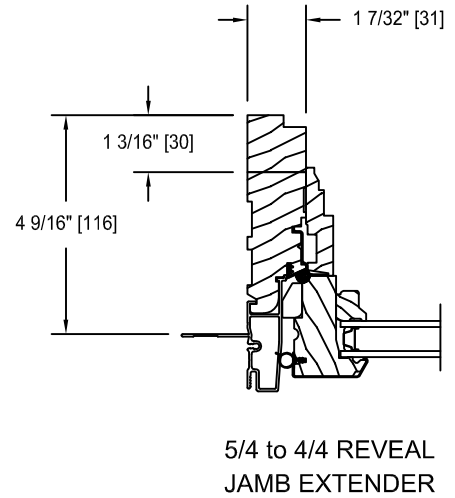
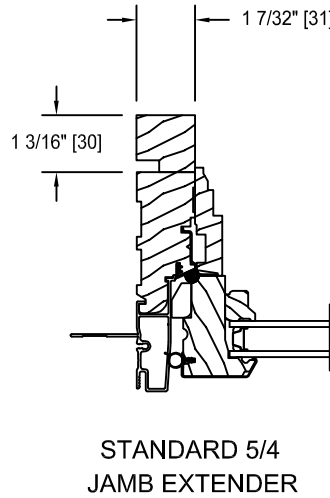
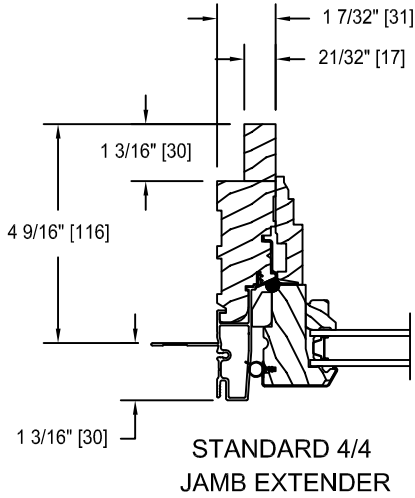

6 9/16" WALL

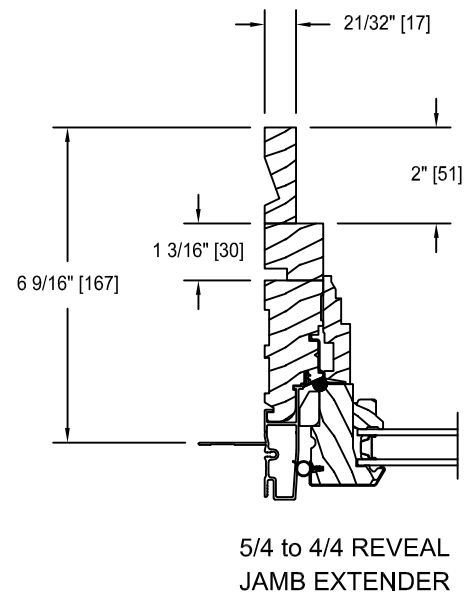
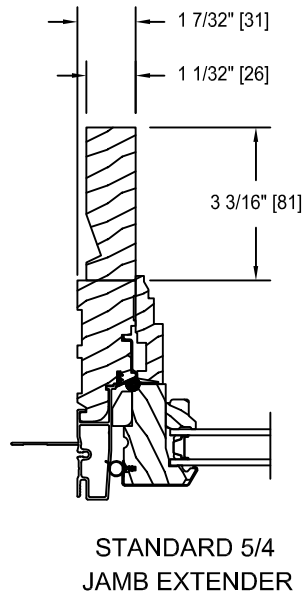
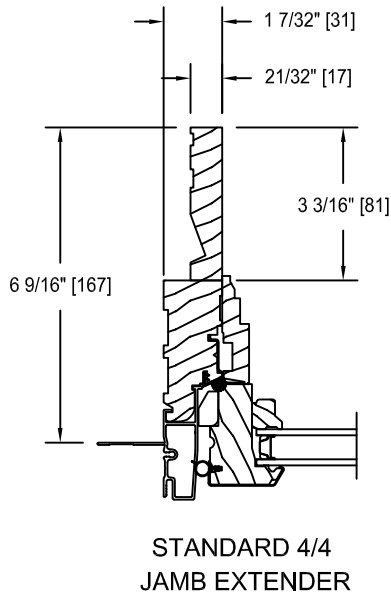

MAXIMUM JAMB WIDTHS

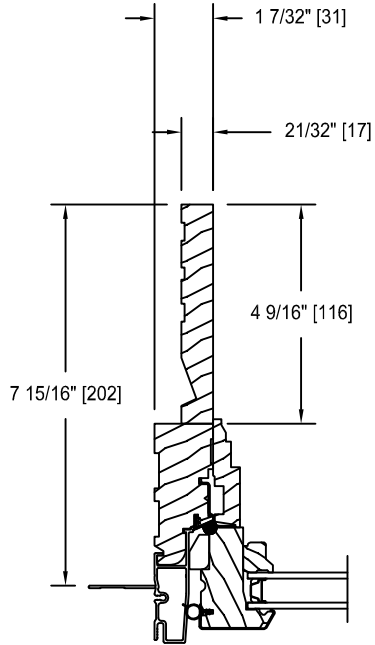

STANDARD 4/4
JAMB EXTENDER

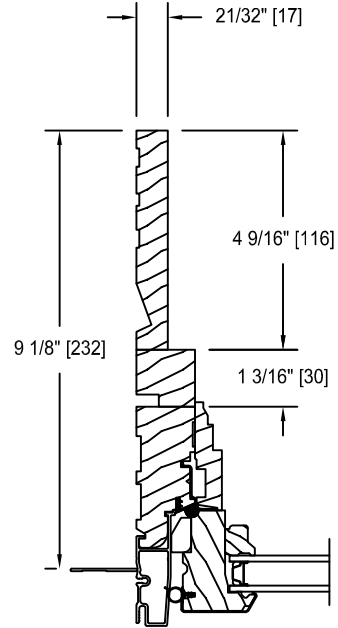

5/4 to 4/4 REVEAL
JAMB EXTENDER

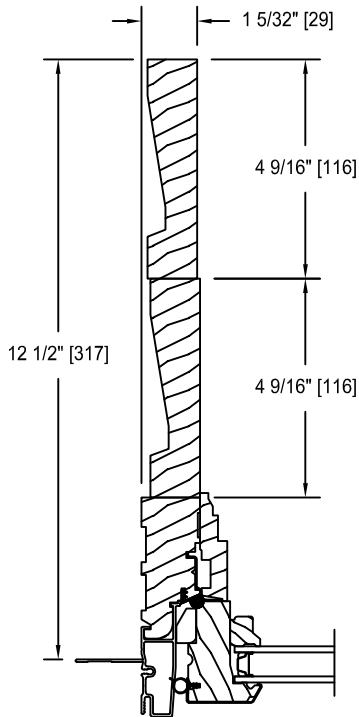

STANDARD 5/4
JAMB EXTENDER

STANDARD MULLION DETAILS

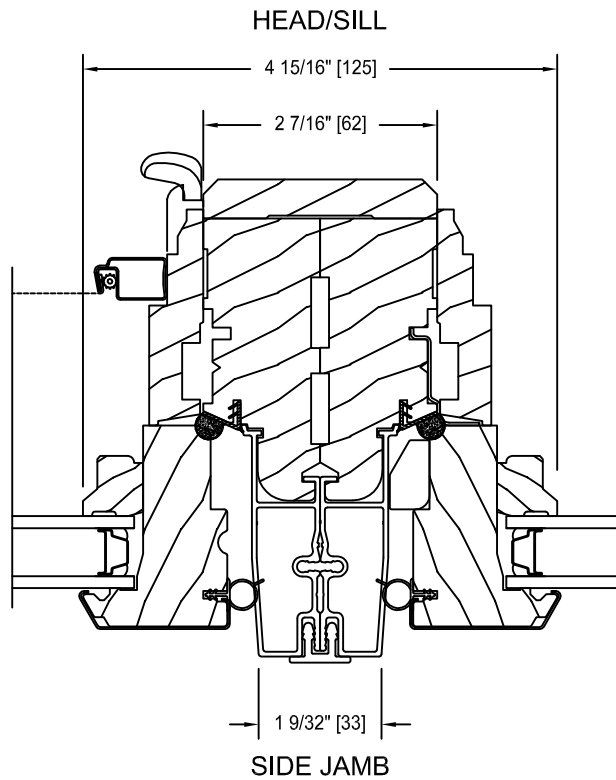
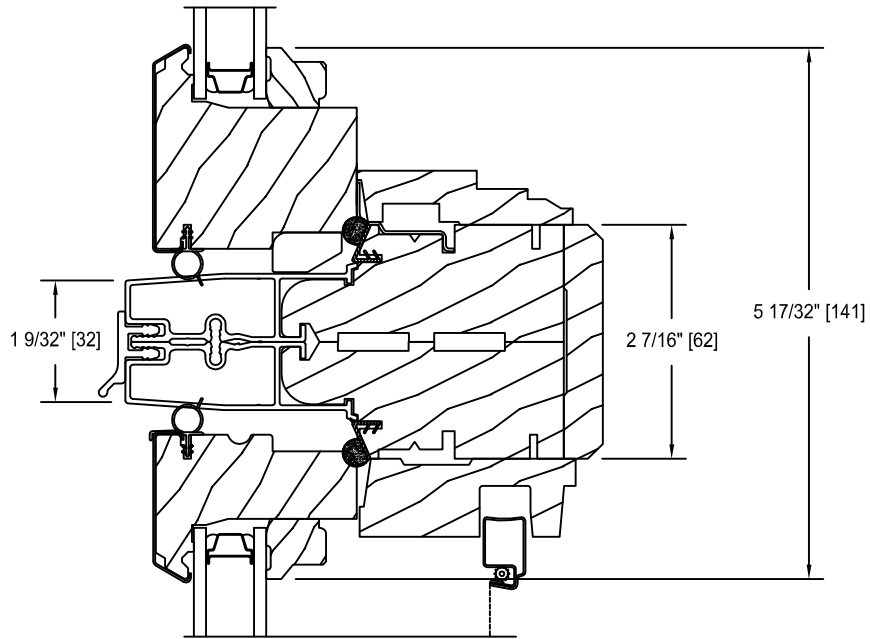

SPECIALTY EXTERIOR TRIM OPTIONS

FRAME EXTENSIONS & RETURNS

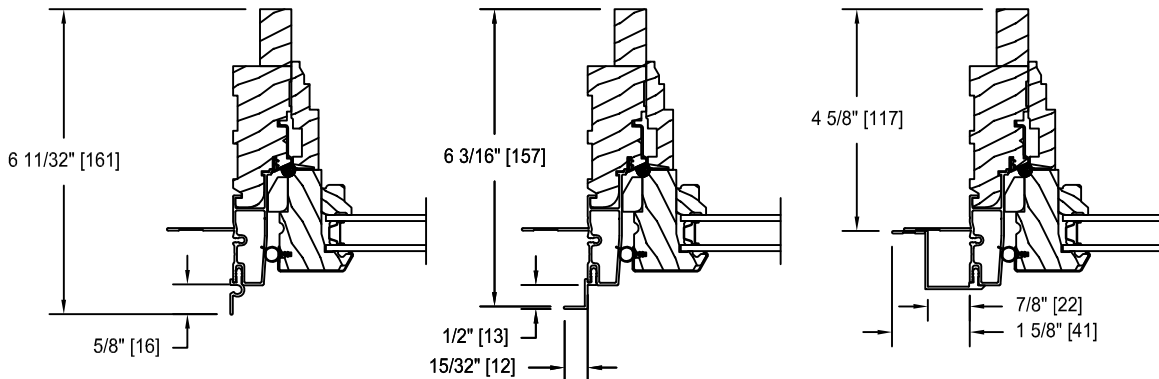

FRAME EXPANDERS
STRAIGHTLINE ONLY

FRAME EXPANDER CAPS
STRAIGHTLINE ONLY

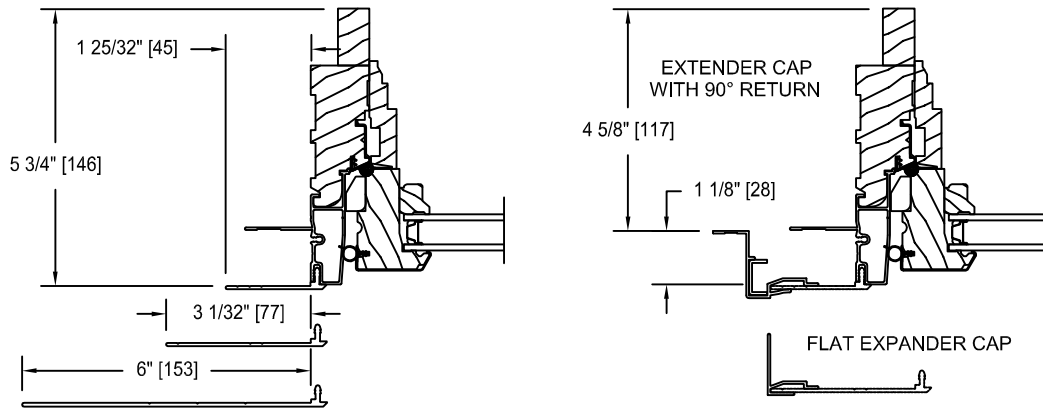

SNAP TRIM OPTIONS

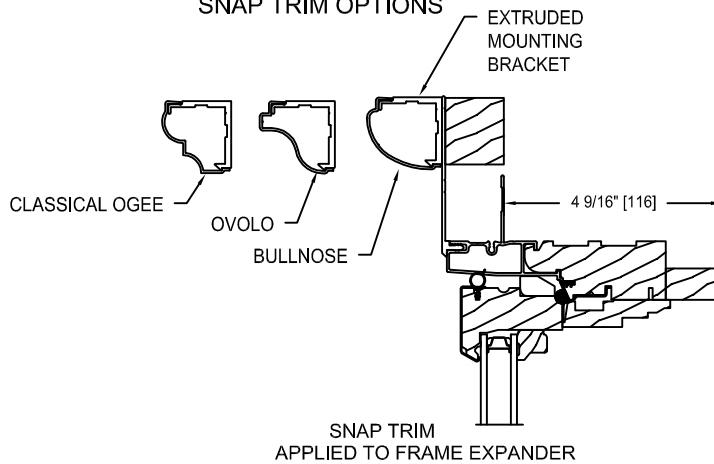

SNAP TRIM
APPLIED TO FRAME EXPANDER

SPECIALTY TRIM & MULLION DETAILS
SPREAD MULLION DETAILS
CLAD CASEMENT

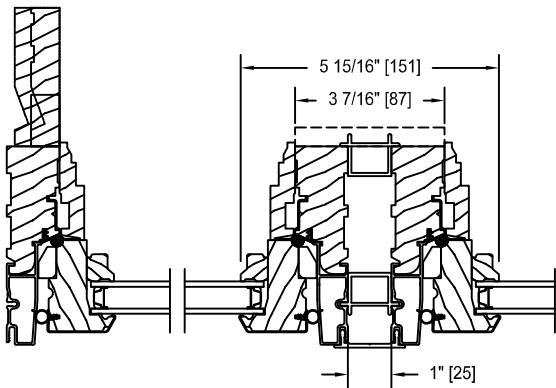
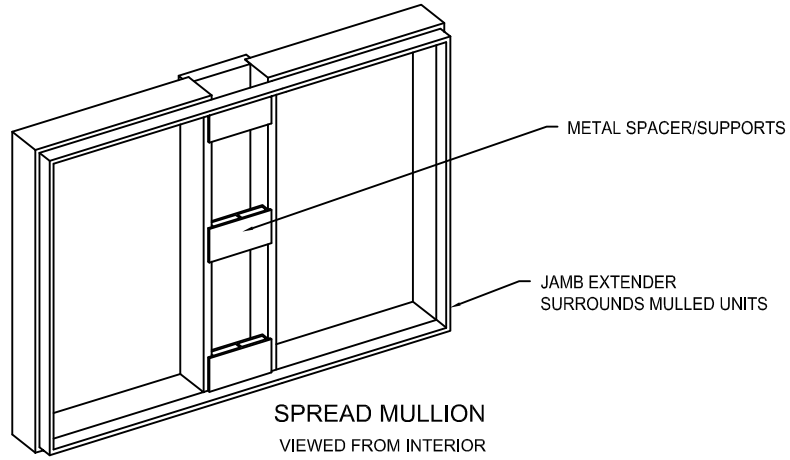

1" SPREAD MULLION

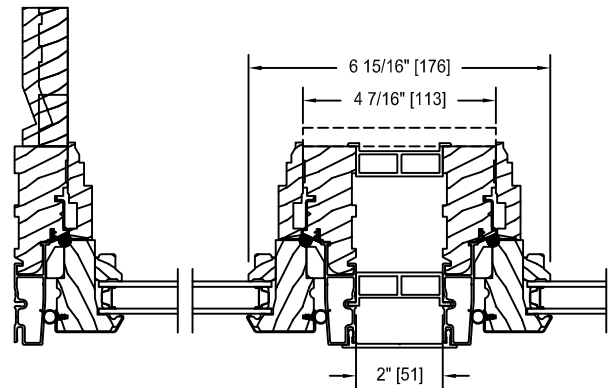

2" SPREAD MULLION

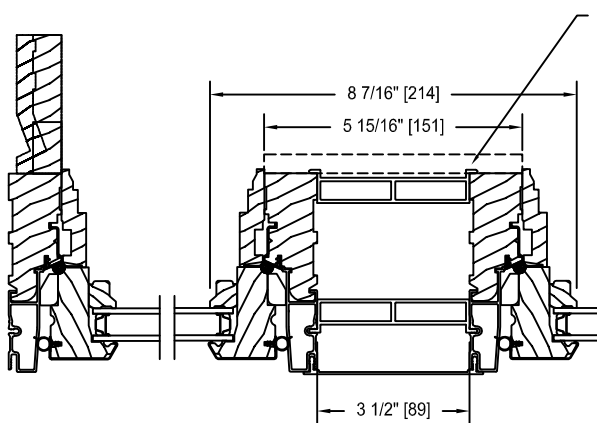

3 1/2" SPREAD MULLION

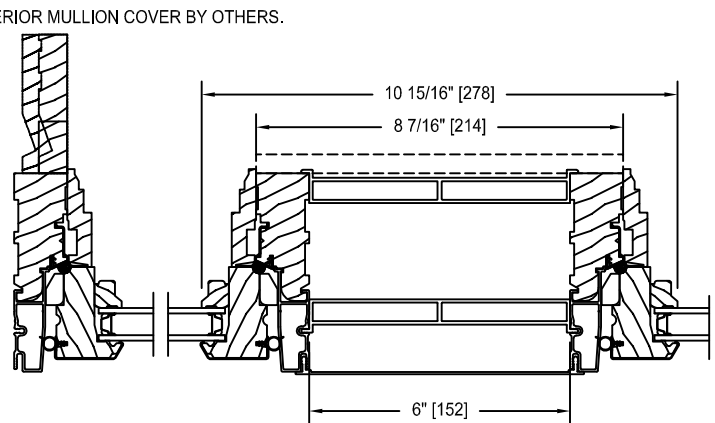

6" SPREAD MULLION

SPECIALTY TRIM & MULLION DETAILS
STUD POCKET DETAILS
CLAD CASEMENT

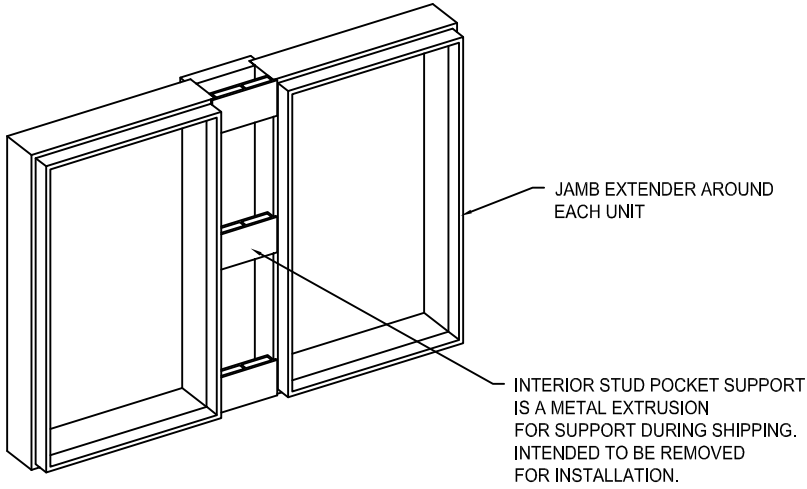

STUD POCKET MULLION
VIEWED FROM INTERIOR

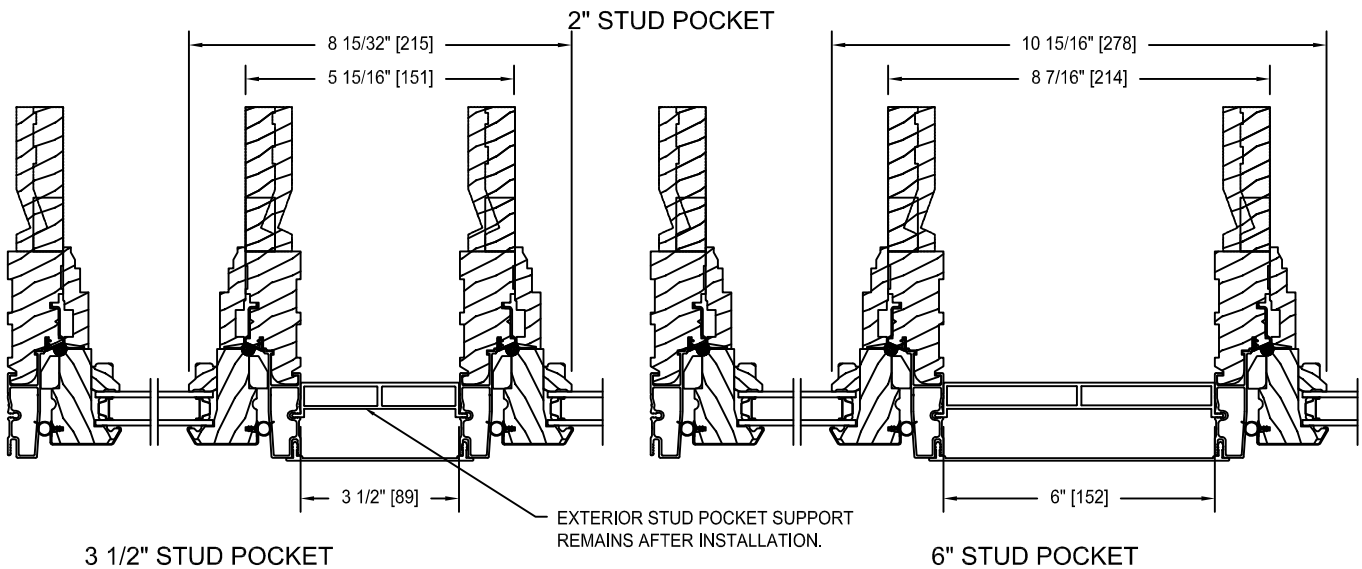
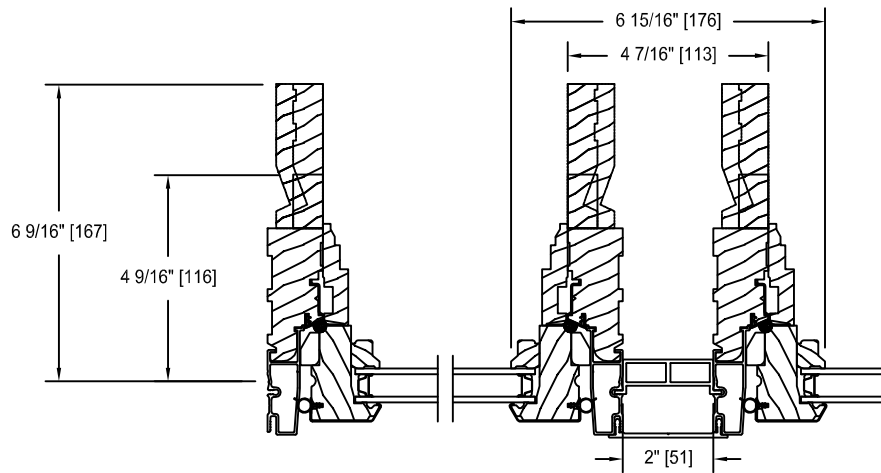

SPECIALTY TRIM & MULLION DETAILS
SPREAD MULLION DETAILS

EXTERIOR SPREAD MULLIONS &
STUD POCKET COVERS

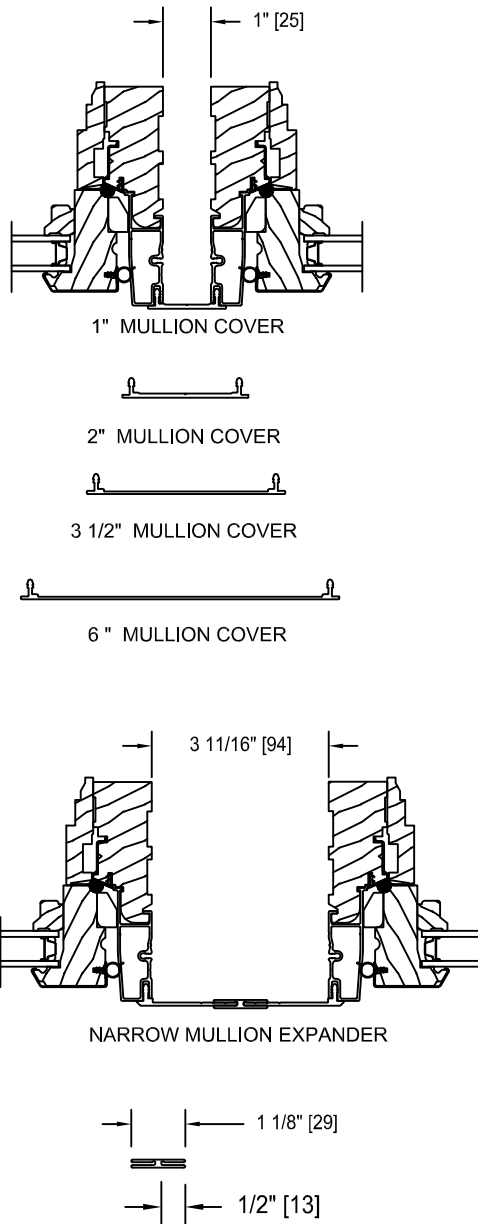

90° CORNER MULLION

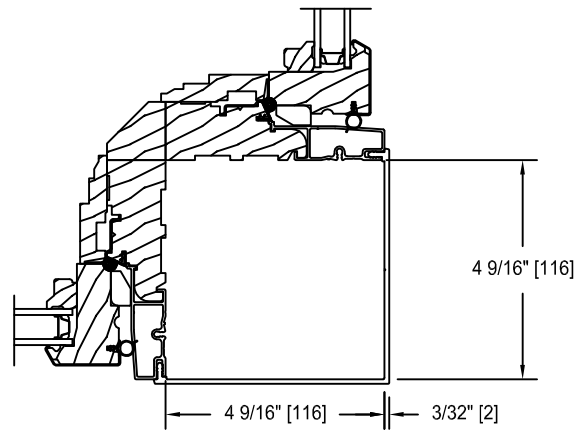

MULLION EXPANDERS

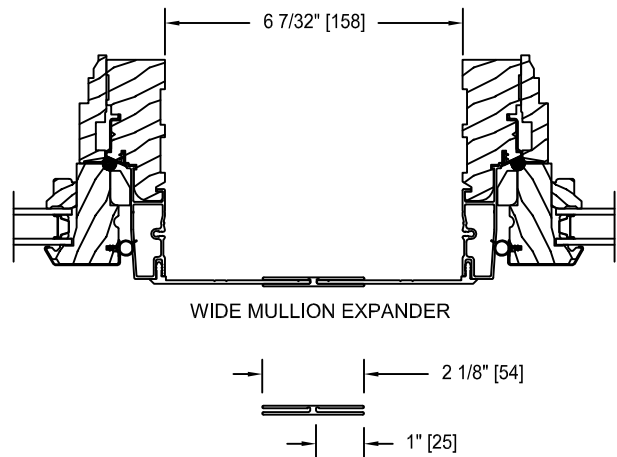

GLAZING OPTIONS
CASEMENT
INTERIOR GLAZED
INSULATED 3/4" [19] GLASS

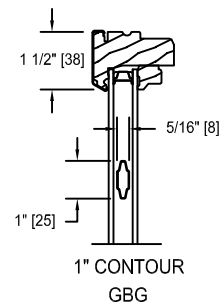
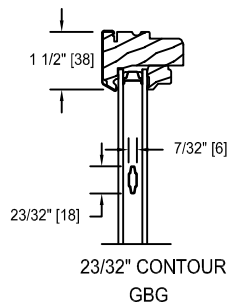
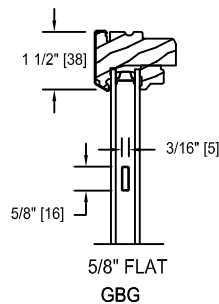
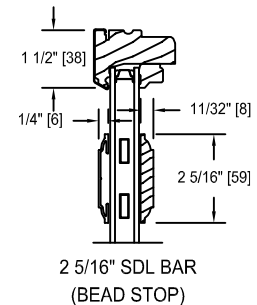
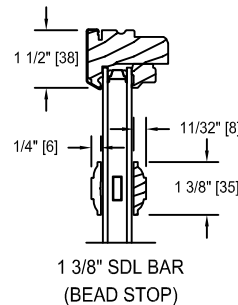
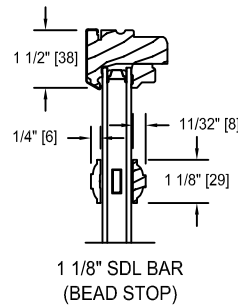
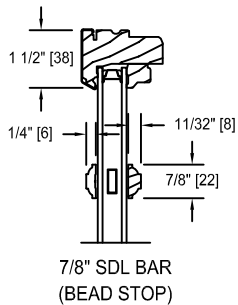
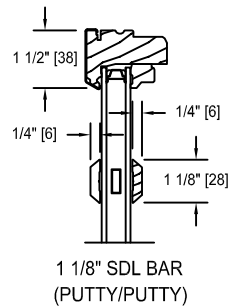
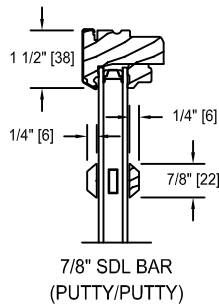
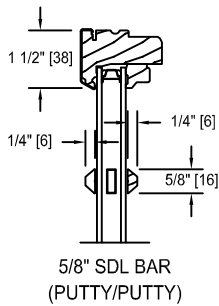
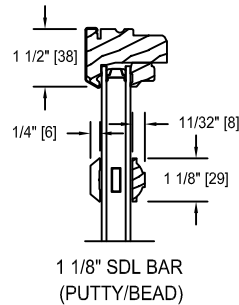
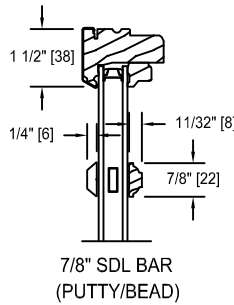
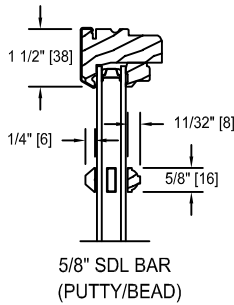
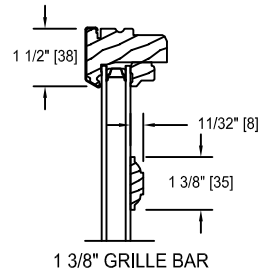
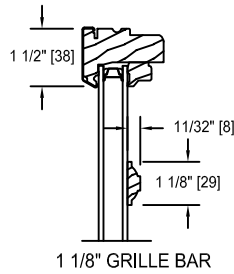
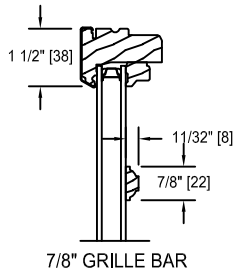

GLAZING OPTIONS
CASEMENT
INTERIOR GLAZED
INSULATED 1/8" [3] GLASS

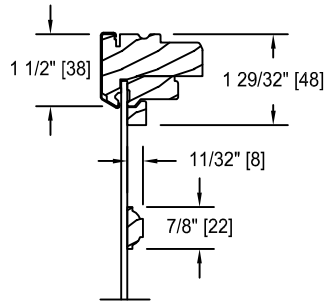

7/8" GRILLE BAR

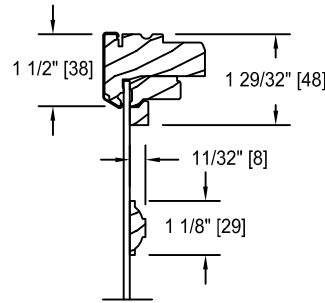

1 1/8" GRILLE BAR

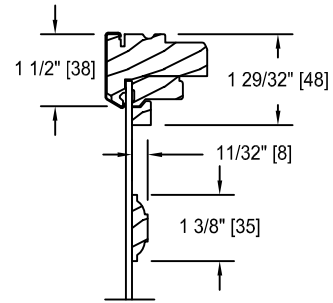

1 3/8" GRILLE BAR

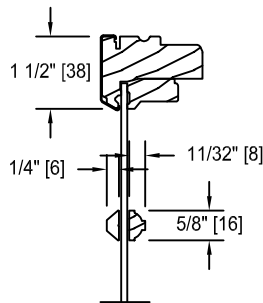

5/8" SDL
(PUTTY/BEAD)

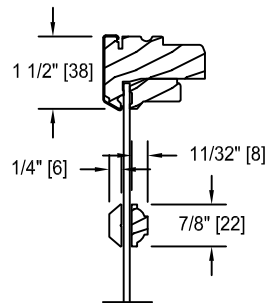

7/8" SDL
(PUTTY/BEAD)

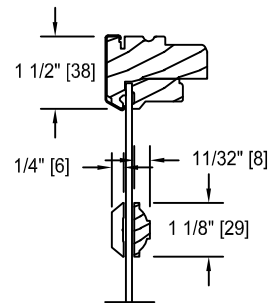

1 1/8" SDL
(PUTTY/BEAD)

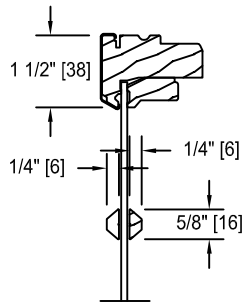

5/8" SDL
(PUTTY/PUTTY)

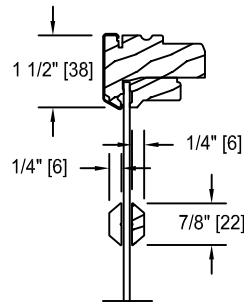

7/8" SDL
(PUTTY/PUTTY)

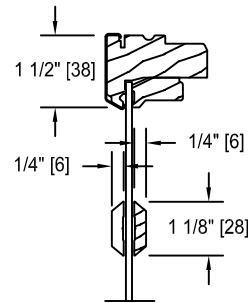

1 1/8" SDL
(PUTTY/PUTTY)

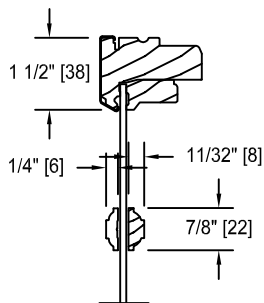

7/8" SDL
(BEAD STOP)

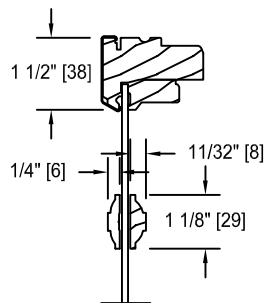

1 1/8" SDL
(BEAD STOP)

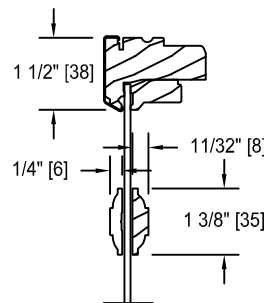

1 3/8" SDL
(BEAD STOP)

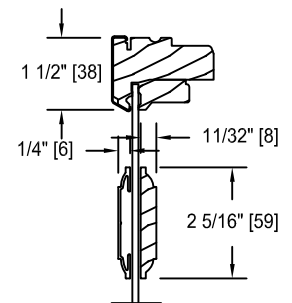

2 5/16" SDL BAR
(BEAD STOP)

GLAZING OPTIONS
CASEMENT
INTERIOR GLAZED
IMPACT RESISTANT GLASS

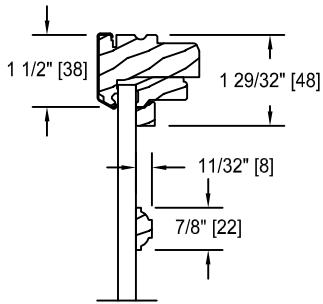

7/8" GRILLE BAR

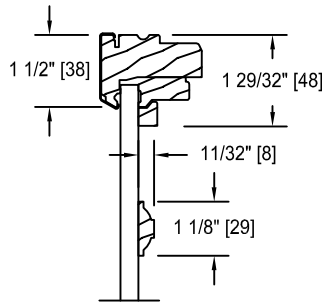

1 1/8" GRILLE BAR

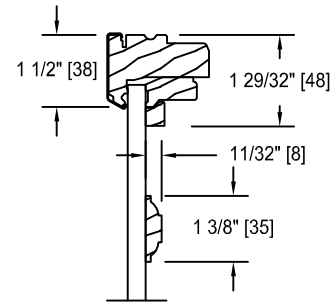

1 3/8" GRILLE BAR

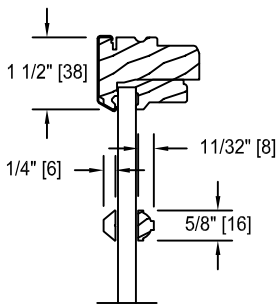

5/8" SDL
(PUTTY/BEAD)

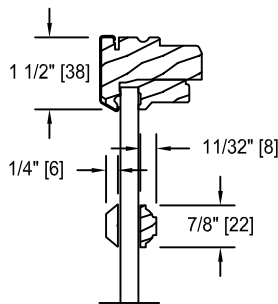

7/8" SDL
(PUTTY/BEAD)

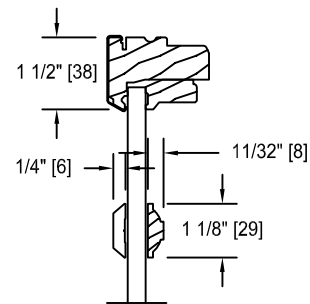

1 1/8" SDL
(PUTTY/BEAD)

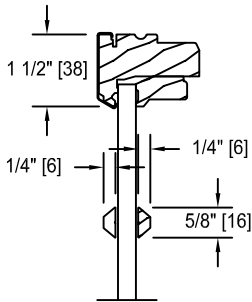

5/8" SDL
(PUTTY/PUTTY)

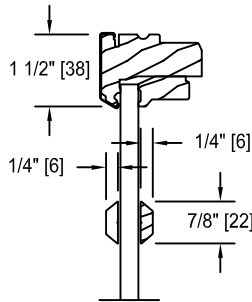

7/8" SDL
(PUTTY/PUTTY)

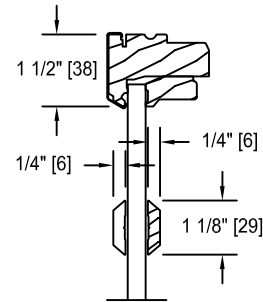

1 1/8" SDL
(PUTTY/PUTTY)

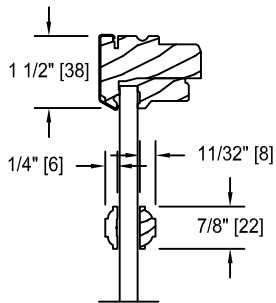

7/8" SDL
(BEAD STOP)

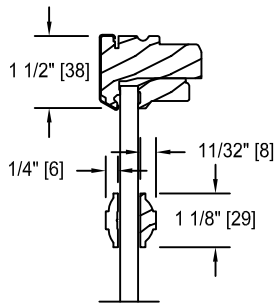

1 1/8" SDL
(BEAD STOP)

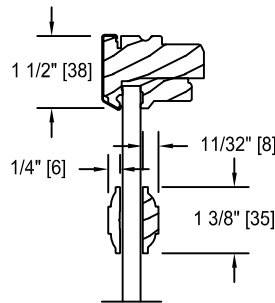

1 3/8" SDL
(BEAD STOP)

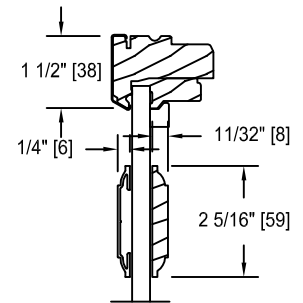

2 5/16" SDL BAR
(BEAD STOP)

GLAZING OPTIONS
SECTOR TOP CASEMENT
INTERIOR GLAZED
INSULATED 3/4" [19] GLASS

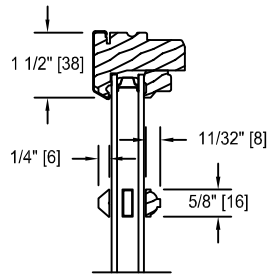

5/8" SDL BAR
(PUTTY/BEAD)

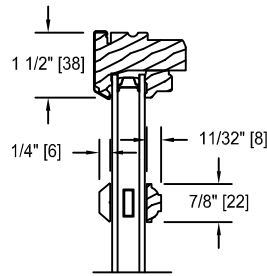

7/8" SDL BAR
(PUTTY/BEAD)

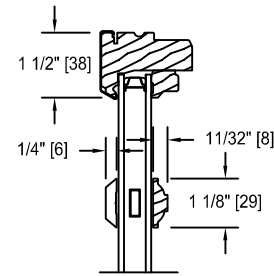

1 1/8" SDL BAR
(PUTTY/BEAD)

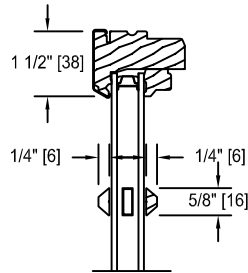

5/8" SDL BAR
(PUTTY/PUTTY)

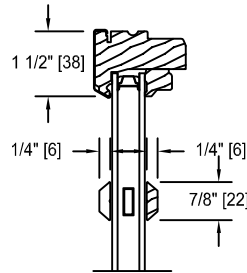

7/8" SDL BAR
(PUTTY/PUTTY)

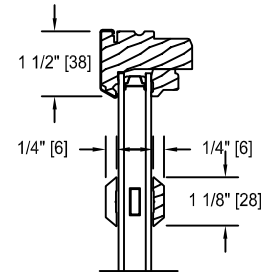

1 1/8" SDL BAR
(PUTTY/PUTTY)

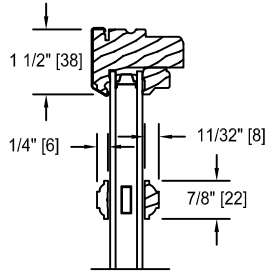

7/8" SDL BAR
(BEAD STOP)

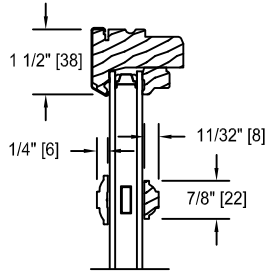

1 1/8" SDL BAR
(BEAD STOP)

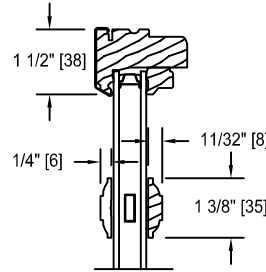

1 3/8" SDL BAR
(BEAD STOP)

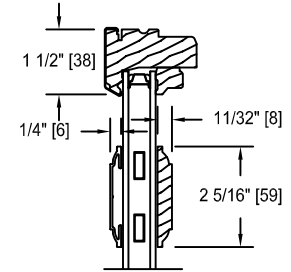

2 5/16" SDL BAR
(BEAD STOP)

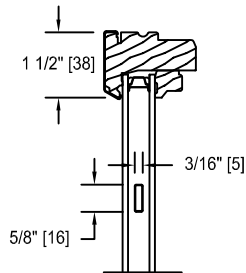

5/8" FLAT
GBG

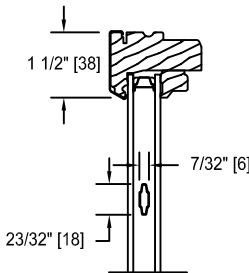

23/32" CONTOUR
GBG

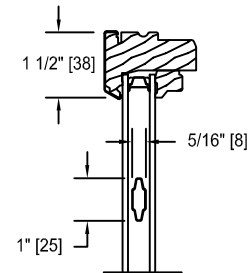

1" CONTOUR
GBG

GLAZING OPTIONS
SECTOR TOP CASEMENT
INTERIOR GLAZED
SINGLE GLAZED 1/8" [3] GLASS

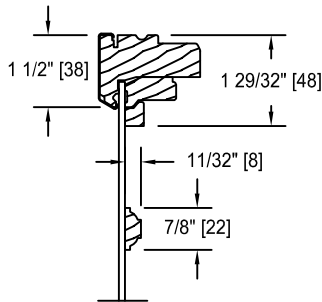

7/8" GRILLE BAR

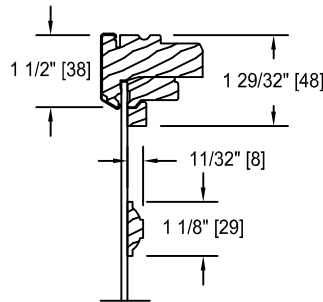

1 1/8" GRILLE BAR

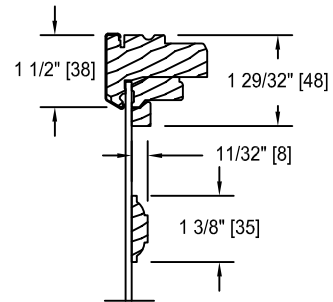

1 3/8" GRILLE BAR

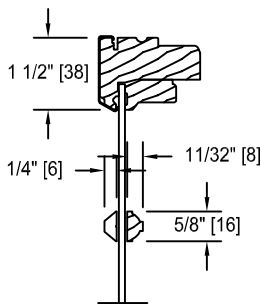

5/8" SDL
(PUTTY/BEAD)

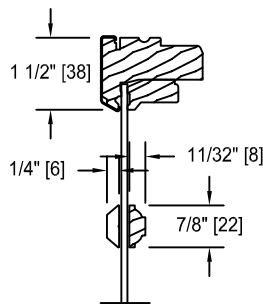

7/8" SDL
(PUTTY/BEAD)

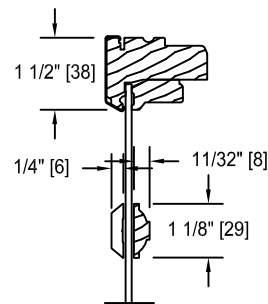

1 1/8" SDL
(PUTTY/BEAD)

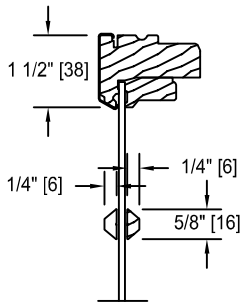

5/8" SDL
(PUTTY/PUTTY)

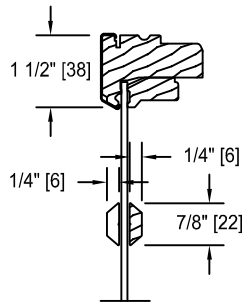

7/8" SDL
(PUTTY/PUTTY)

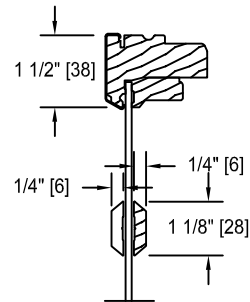

1 1/8" SDL
(PUTTY/PUTTY)

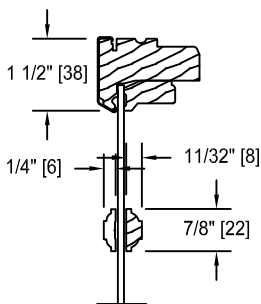

7/8" SDL
(BEAD STOP)

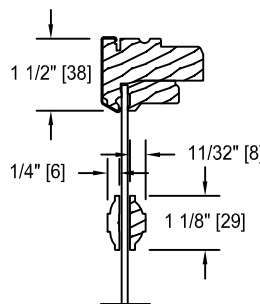

1 1/8" SDL
(BEAD STOP)

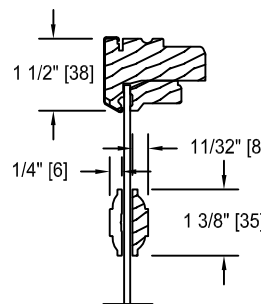

1 3/8" SDL
(BEAD STOP)

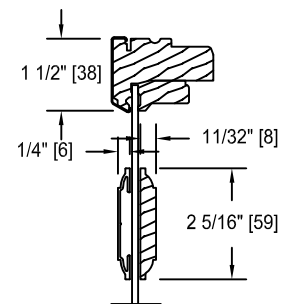

2 5/16" SDL BAR
(BEAD STOP)

GLAZING OPTIONS
SECTOR TOP CASEMENT
INTERIOR GLAZED
IMPACT RESISTANT GLASS

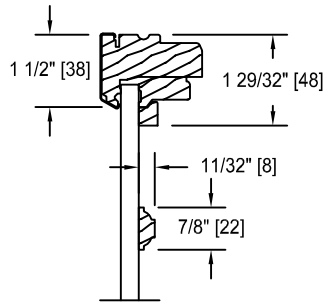

7/8" GRILLE BAR

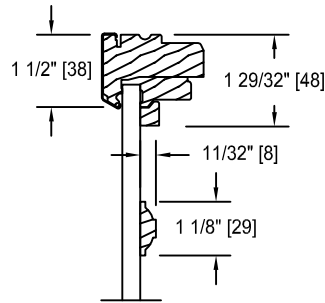

1 1/8" GRILLE BAR

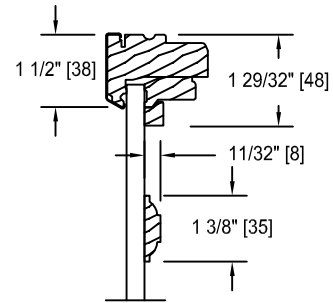

1 3/8" GRILLE BAR

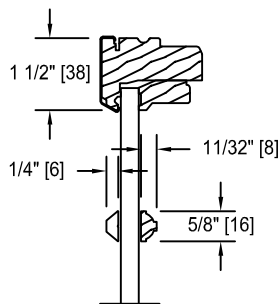

5/8" SDL
(PUTTY/BEAD)

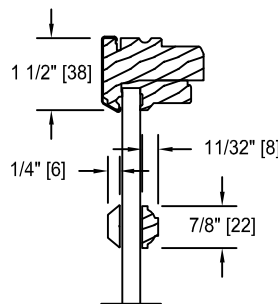

7/8" SDL
(PUTTY/BEAD)

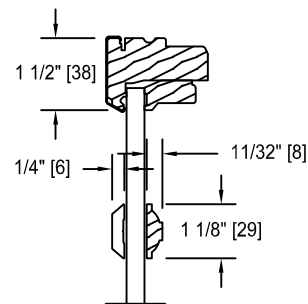

1 1/8" SDL
(PUTTY/BEAD)

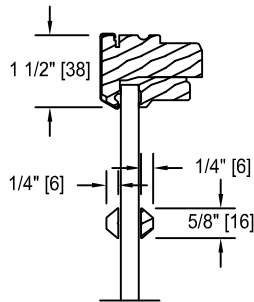

5/8" SDL
(PUTTY/PUTTY)

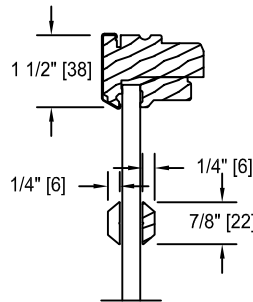

7/8" SDL
(PUTTY/PUTTY)

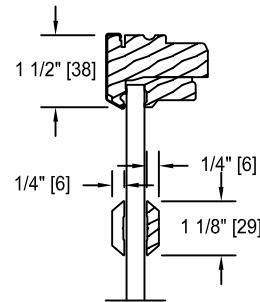

1 1/8" SDL
(PUTTY/PUTTY)

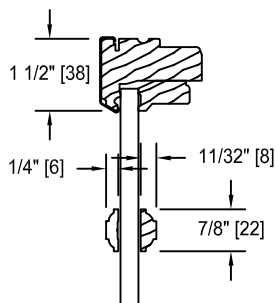

7/8" SDL
(BEAD STOP)

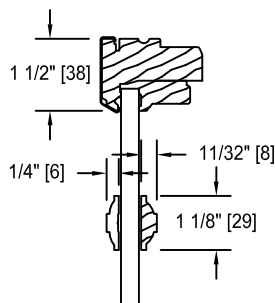

1 1/8" SDL
(BEAD STOP)

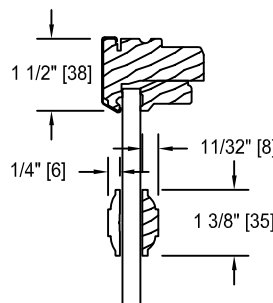

1 3/8" SDL
(BEAD STOP)

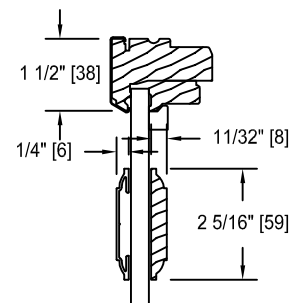

2 5/16" SDL BAR
(BEAD STOP)

ELEVATION NOTES
CASEMENT

ELEVATION DRAWINGS UTILIZE A LIMITED NUMBER OF PROJECTED LINES TO PRODUCE A RUDIMENTARY DRAWING INTENDED TO BE USED IN A SMALL GRAPHICAL SCALE. ELEVATIONS ARE VIEWED PERPENDICULAR FROM THE EXTERIOR OF THE STRUCTURE. IF MORE DIMENSIONS ARE NEEDED, USE THE SECTION DRAWINGS FOR MORE COMPLETE DEPICTIONS.

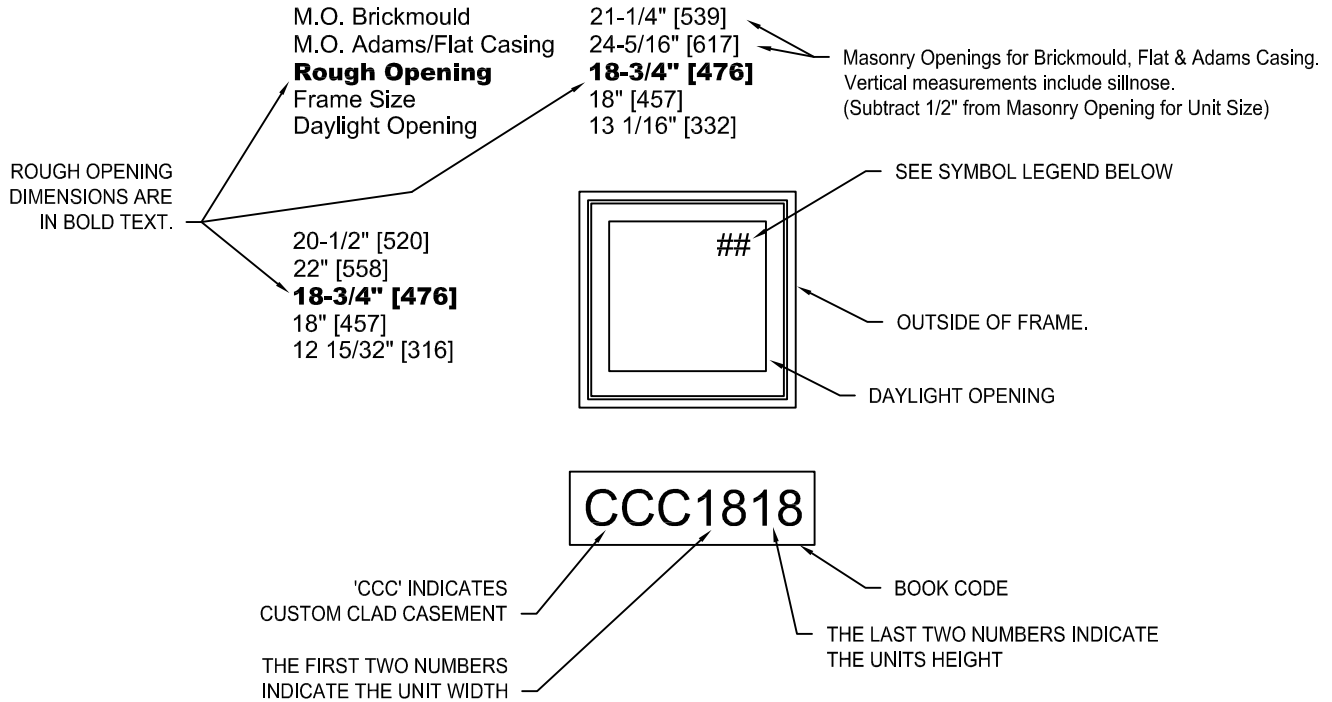

GENERAL CASEMENT NOTES

1. CUSTOM CLAD CASEMENT (CCC) UNITS ARE AVAILABLE AS OPERATING OR FIXED UNITS.
2. 'CCCP' IN A BOOK CODE DENOTES THE UNIT IS A CLAD CASEMENT PICTURE (FIXED) UNIT.
3. UNIT ELEVATIONS ARE SHOWN WITHOUT EXTERIOR TRIM. UNIT SIZES & MASONRY OPENING DIMENSIONS WILL CHANGE WITH THE ADDITION OF EXTERIOR TRIM. SEE THE 'UNIT SIZING, ROUGH OPENINGS & MASONRY OPENINGS' PAGE FOR EXTERIOR TRIM EFFECTS.
4. OPERATING UNITS ARE AVAILABLE AS LEFT OR RIGHT HAND OPERATION.
5. DIMENSIONAL VALUES IN BRACKETS ARE MILLIMETER CONVERSIONS.

ELEVATION SYMBOL LEGEND:

- E** BASIC UNIT CLEAR OPENING EXCEEDS 20" IN WIDTH, 24" IN HEIGHT & A MINIMUM OF 5.7 SQ. FT.
- E*** BASIC UNIT CLEAR OPENING REQUIRES EGRESS HINGES TO EXCEED 20" IN WIDTH, 24" IN HEIGHT & A MINIMUM OF 5.7 SQ. FT.
- E1** BASIC UNIT CLEAR OPENING EXCEEDS 20" IN WIDTH, 24" IN HEIGHT & A MINIMUM OF 5.0 SQ. FT.
- S** STATIONARY UNIT.
- ##** NUMBER INDICATES DESIGN PRESSURE (DP) RATING WITH STANDARD GLAZING. OPERATING UNITS UTILIZE THE R65 LOCKING SYSTEM FOR DP RATINGS.

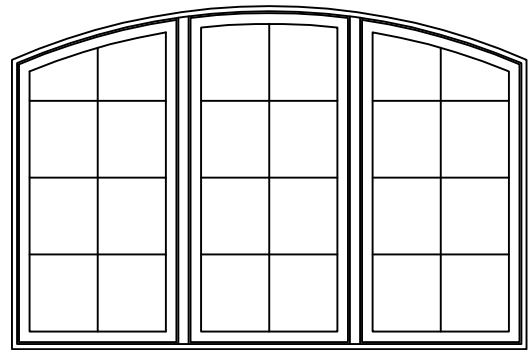
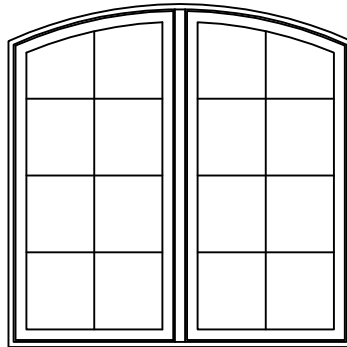
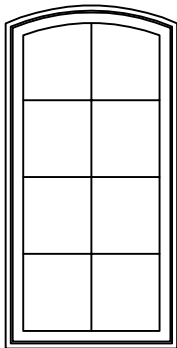
GENERAL INFORMATION
SECTOR TOP CASEMENT

Sector clad casements are constructed the same as Custom clad casements, roll formed cladding on wood sash.

Sector clad casement windows are available with left or right hand operation (hinged on the springline), or stationary (non-venting). Operating mechanism includes stainless steel, corrosion resistant, butt hinges and single arm roto-type operator with hardened steel gears and operating arm. Sash locks are concealed unison type with an exposed locking lever and escutcheon plate. There are several interior hardware finish options. Refer to the Specifications for finish options.

Note: Bookcoded sector top units have roll form sash.

CLAD SECTOR TOP CASEMENTS utilize some of the same options as CLAD Custom CASEMENTS. Those options have not been repeated here in this sub-section.

HANDLING & OPERATION
SECTOR TOP CASEMENT

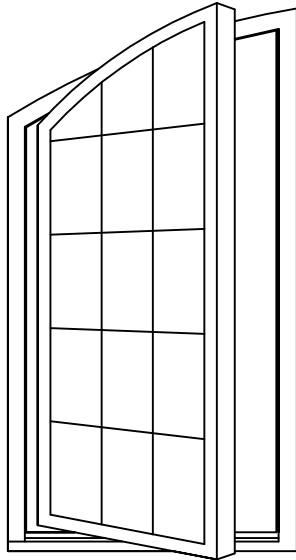

LEFT
HAND

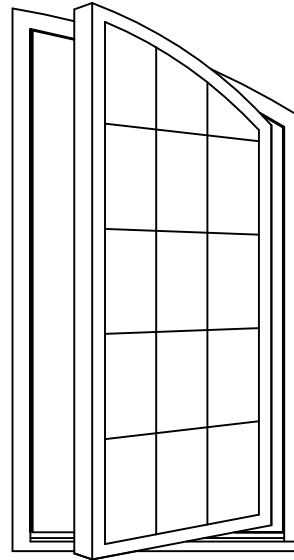

RIGHT
HAND

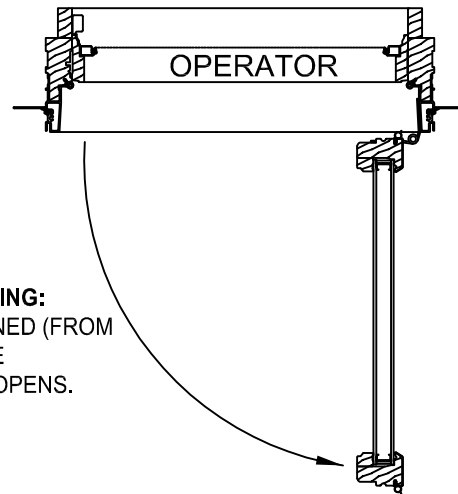
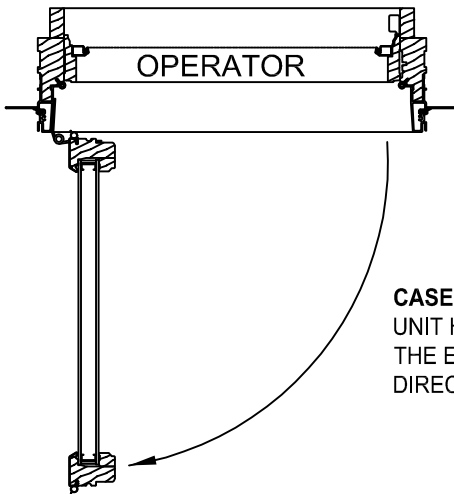

CASEMENT UNIT HANDING:
UNIT HANDING IS DEFINED (FROM
THE EXTERIOR) AS THE
DIRECTION THE SASH OPENS.

UNIT HANDING INFORMATION

OPERATING SINGLE SECTOR UNITS - MAY BE HANDED 'LEFT' OR 'RIGHT'.

OPERATING TWIN SECTOR UNITS - THESE UNITS ARE HINGED ON THE SPRINGLINE SIDE. THE 'LEFT' SASH HAS 'LEFT' HAND OPERATION AND THE 'RIGHT' SASH HAS 'RIGHT' HAND OPERATION ONLY.

OPERATING TRIPLE SECTOR UNITS - ONLY THE FLANKING UNITS MAY BE OPERATORS WHICH ARE HINGED ON THE SPRINGLINE SIDE. THE TWO OPERATING SASH ARE HANDED THE SAME AS THE TWIN SECTOR.

NOTE: BOOKCODED SECTOR TOP UNITS HAVE ROLL FORM SASH.

ELEVATION NOTES
SECTOR TOP CASEMENT

ELEVATION DRAWINGS UTILIZE A LIMITED NUMBER OF PROJECTED LINES TO PRODUCE A RUDIMENTARY DRAWING INTENDED TO BE USED IN A SMALL GRAPHICAL SCALE. ELEVATIONS ARE VIEWED PERPENDICULAR FROM THE EXTERIOR OF THE STRUCTURE. IF MORE DIMENSIONS ARE NEEDED, USE THE SECTION DRAWINGS FOR MORE COMPLETE DEPICTIONS.

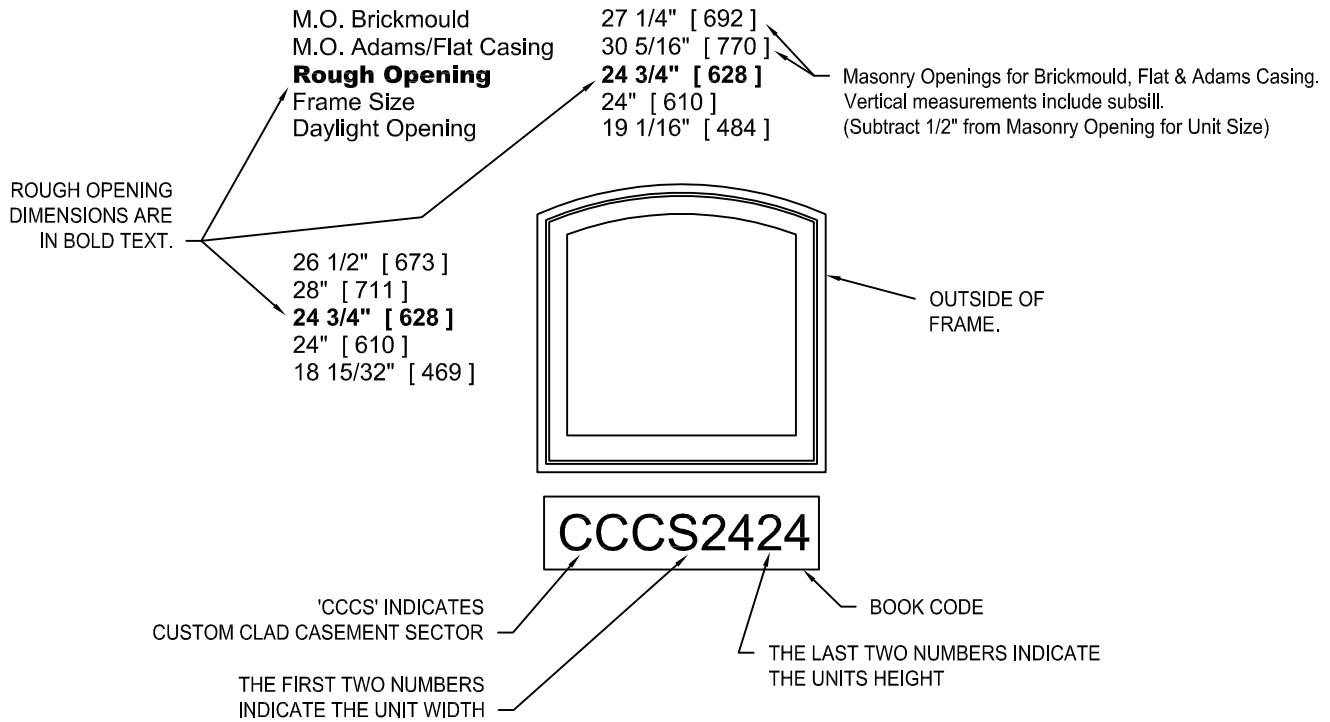

GENERAL RADIUS CASEMENT NOTES

1. UNIT ELEVATIONS ARE SHOWN WITHOUT EXTERIOR TRIM.
2. DIMENSIONAL VALUES IN BRACKETS ARE MILLIMETER CONVERSIONS.
3. ALL SECTOR UNITS ARE AVAILABLE AS OPERATING UNITS.
4. BOOKCODED SECTOR TOP UNITS HAVE ROLL FORM SASH.

ELEVATION SYMBOL LEGEND:

- E** BASIC UNIT CLEAR OPENING EXCEEDS 20" IN WIDTH, 24" IN HEIGHT & A MINIMUM OF 5.7 SQ. FT.
- E1** BASIC UNIT CLEAR OPENING EXCEEDS 20" IN WIDTH, 24" IN HEIGHT & A MINIMUM OF 5.0 SQ. FT.
- S** STATIONARY UNIT.
- ##** NUMBER INDICATES DESIGN PRESSURE (DP) RATING WITH STANDARD GLAZING. OPERATING UNITS UTILIZE THE R65 LOCKING SYSTEM FOR DP RATINGS.

VERTICAL SECTION
OPERATING UNIT

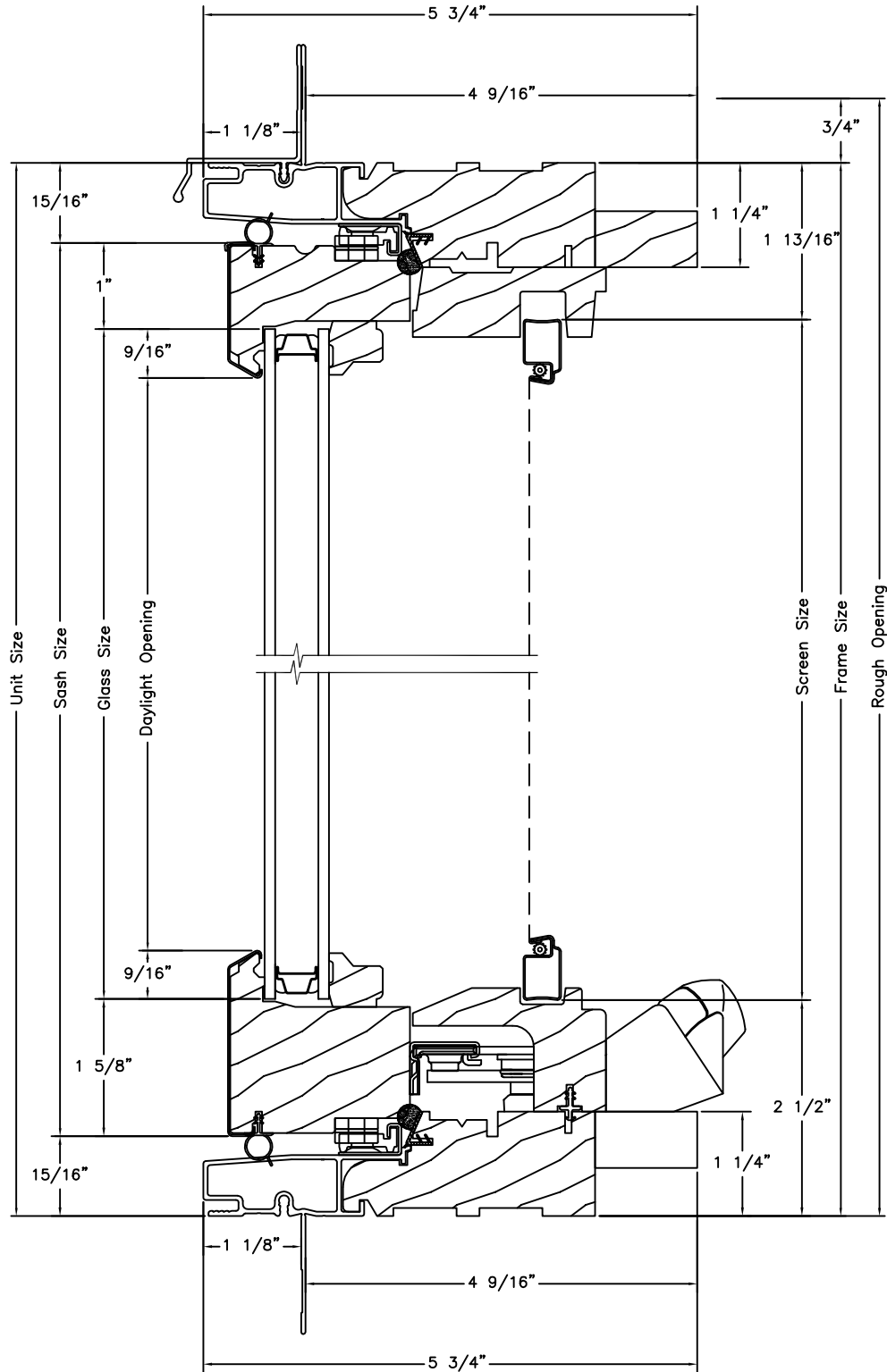

HORIZONTAL SECTION
OPERATING UNIT

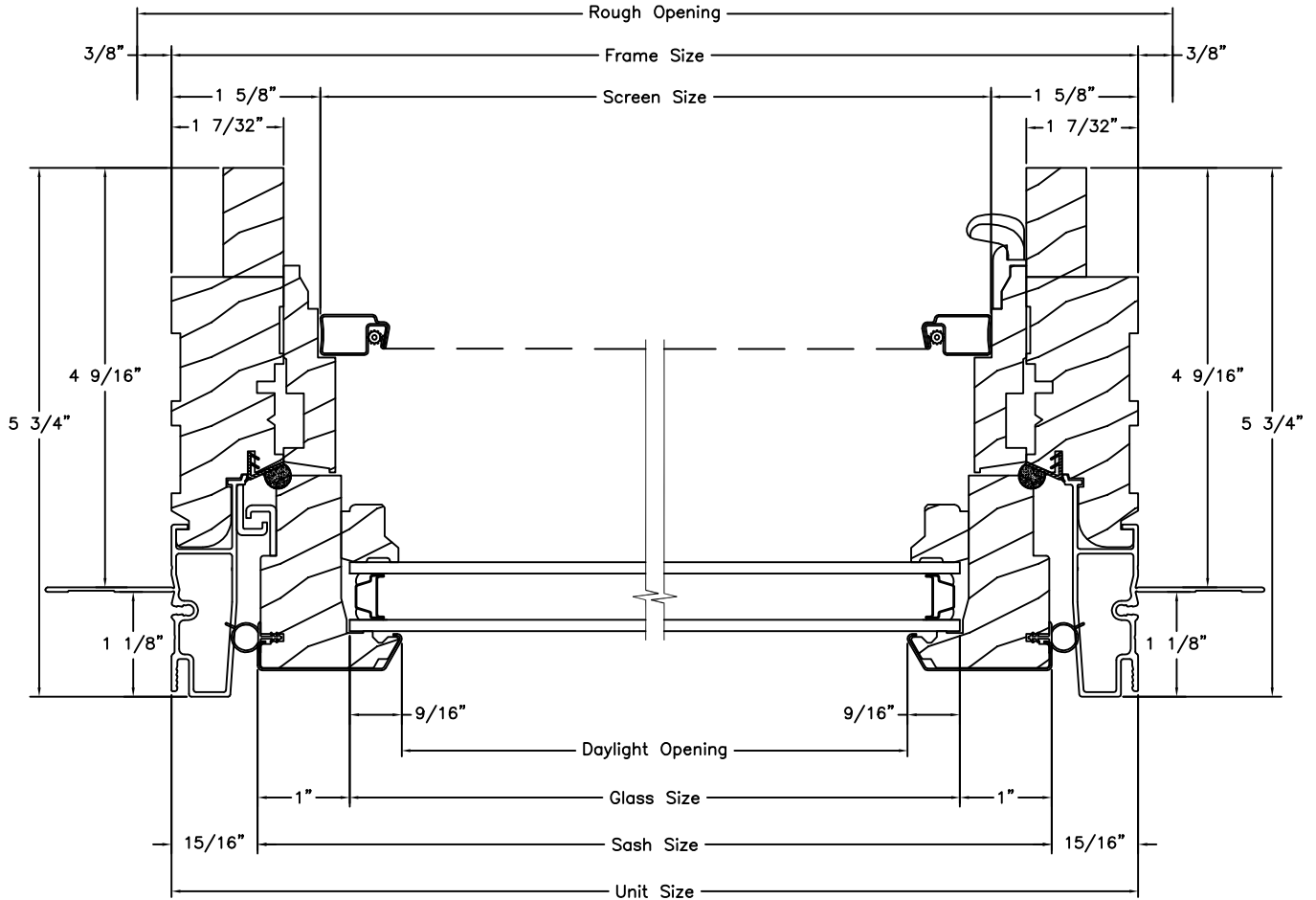

HORIZONTAL SECTION
2-WIDE UNIT

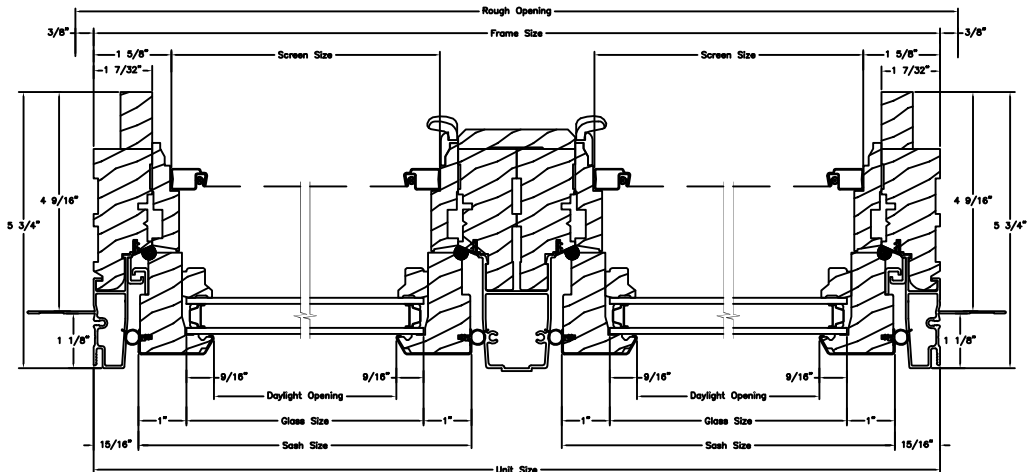

Horizontal Section

**HORIZONTAL SECTION
3-WIDE UNIT**

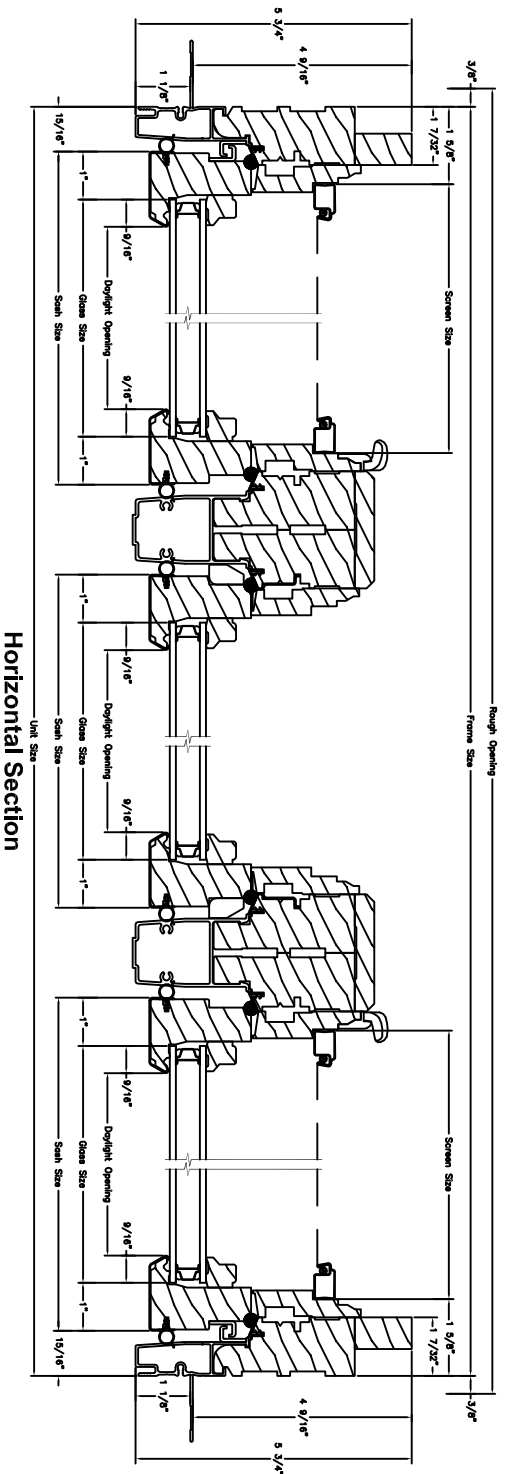

Horizontal Section

VERTICAL SECTION
PICTURE UNIT

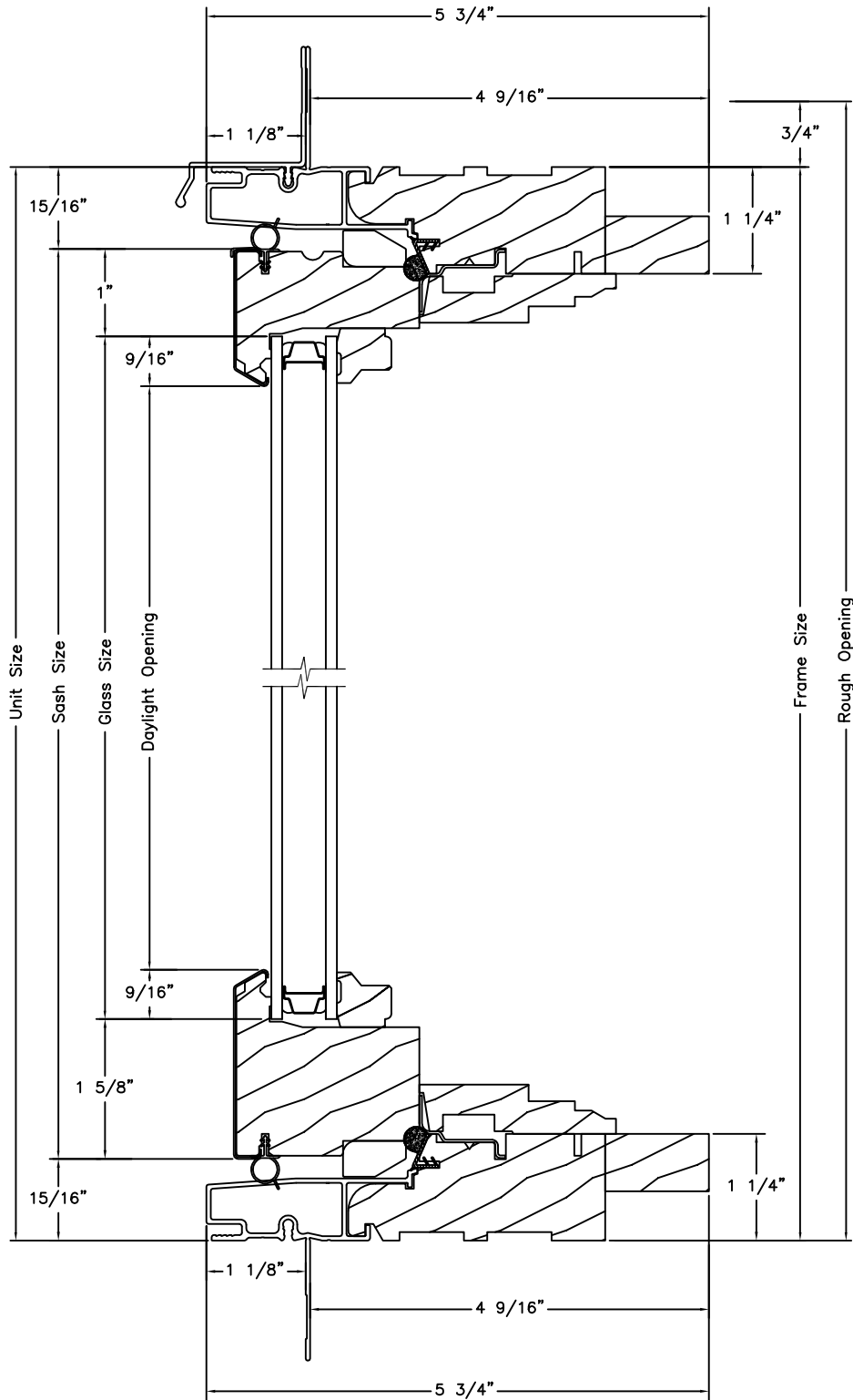

HORIZONTAL SECTION
PICTURE UNIT

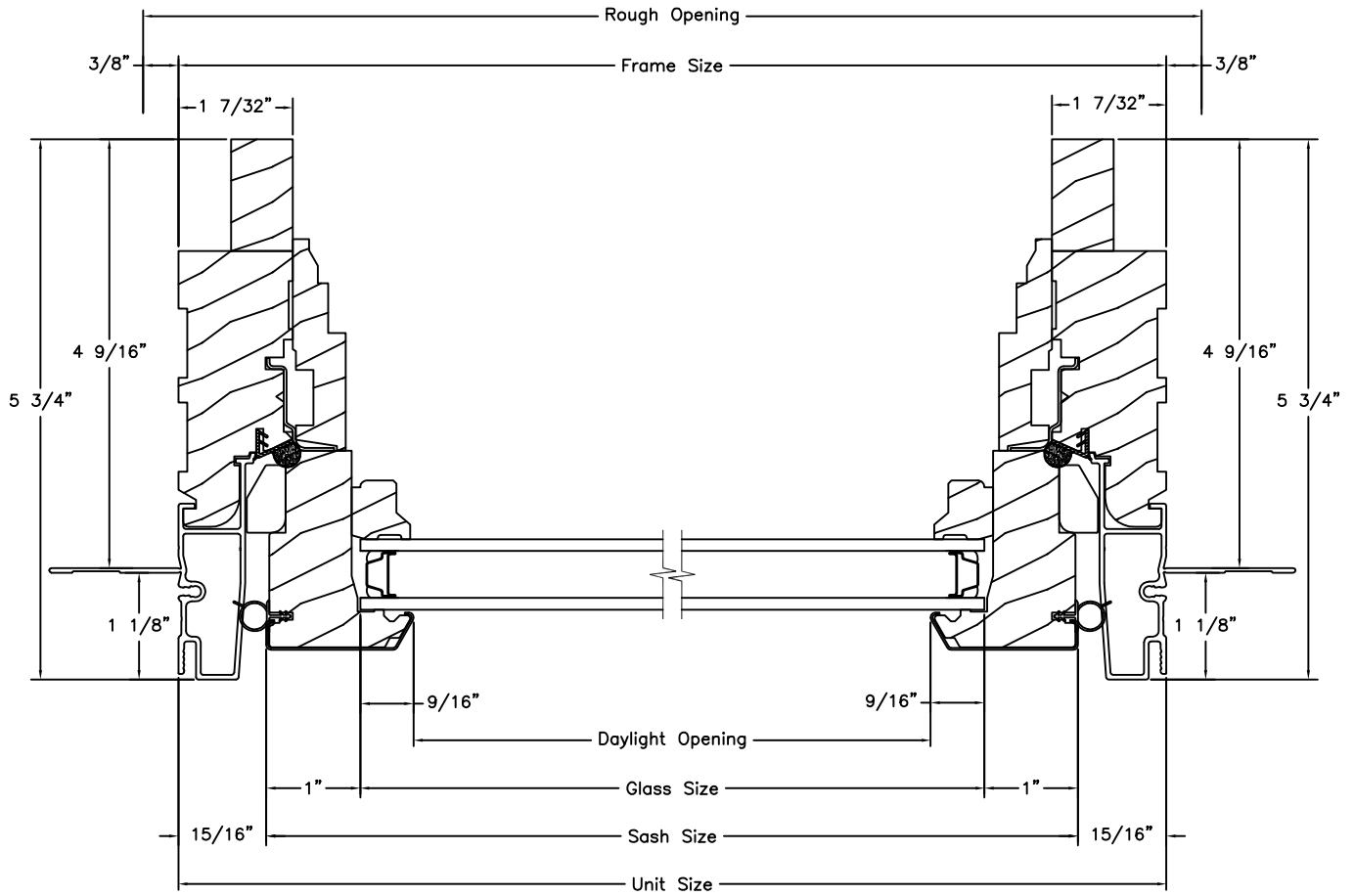

VERTICAL SECTION
SECTOR TOP
OPERATING UNIT

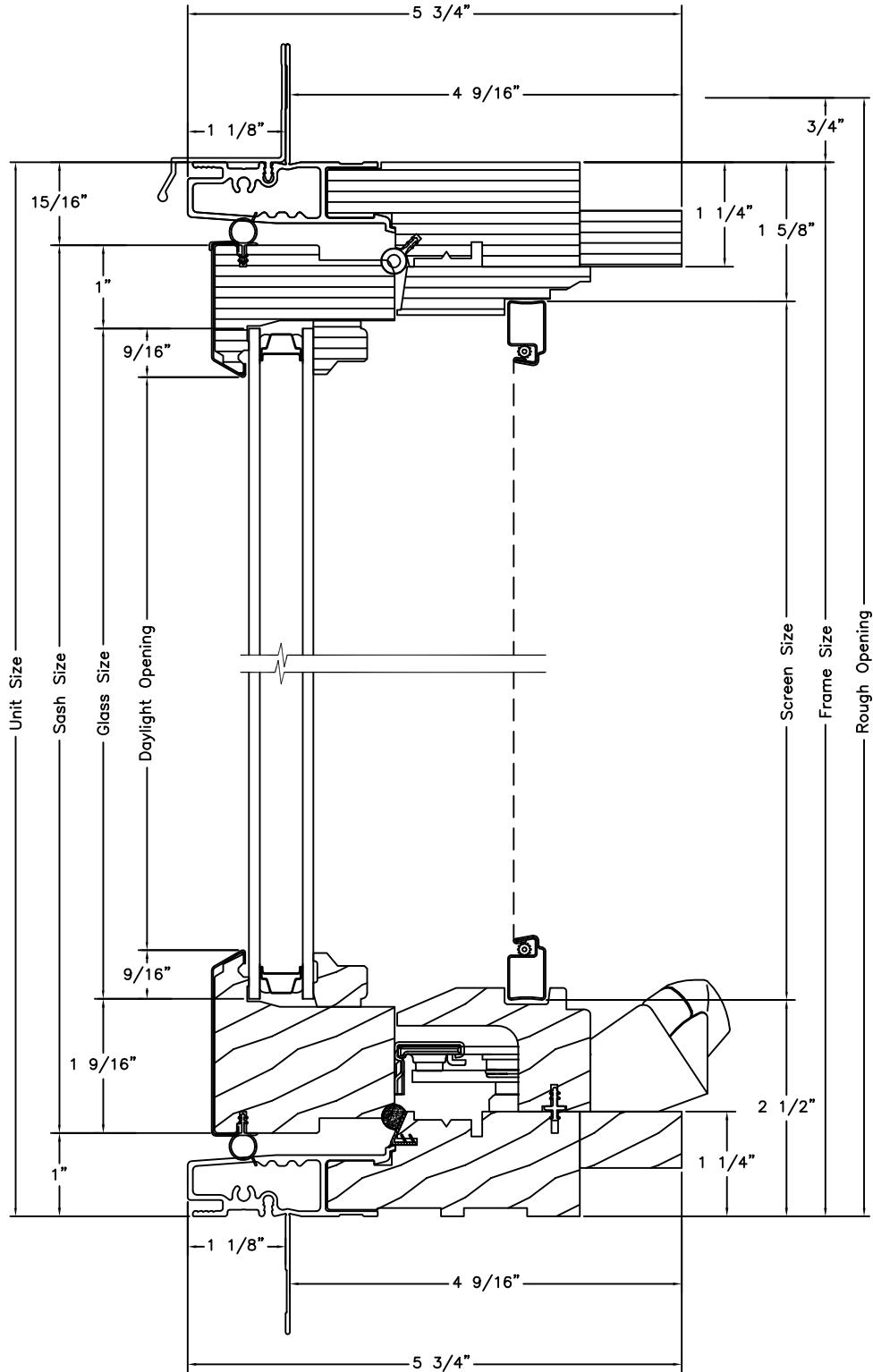

HORIZONTAL SECTION
SECTOR TOP
OPERATING UNIT

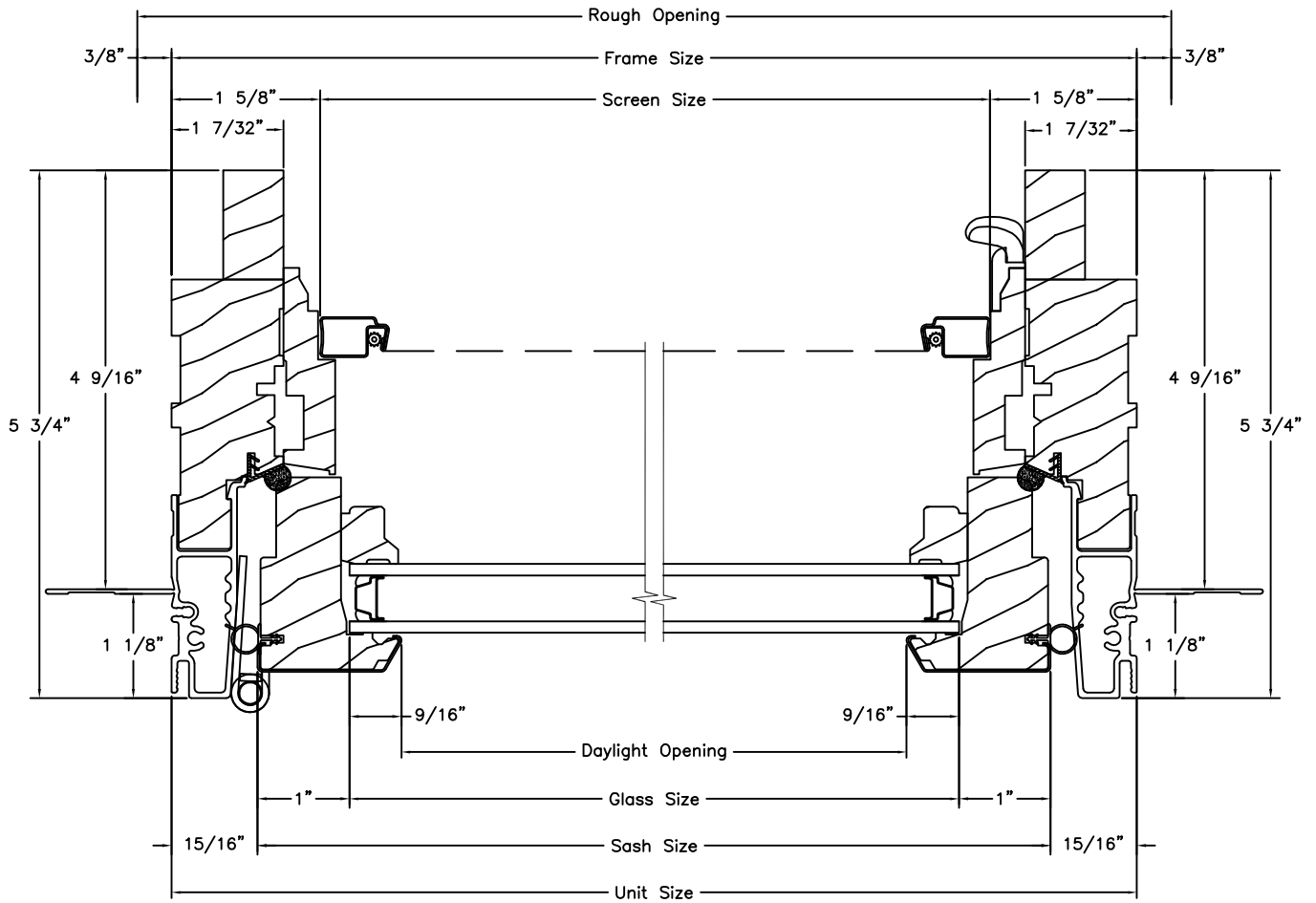

HORIZONTAL SECTION
SECTOR TOP 2-WIDE UNIT

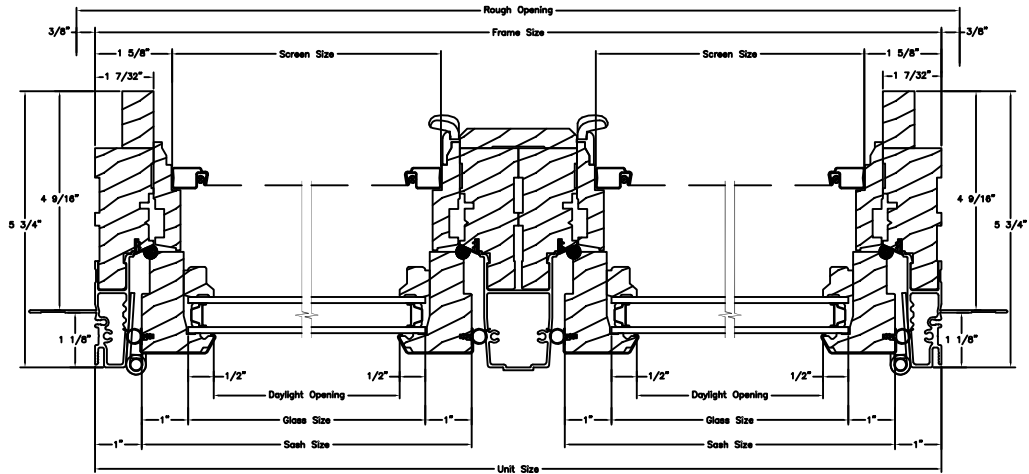

Horizontal Section

**HORIZONTAL SECTION
SECTOR TOP UNIT 3-WIDE**

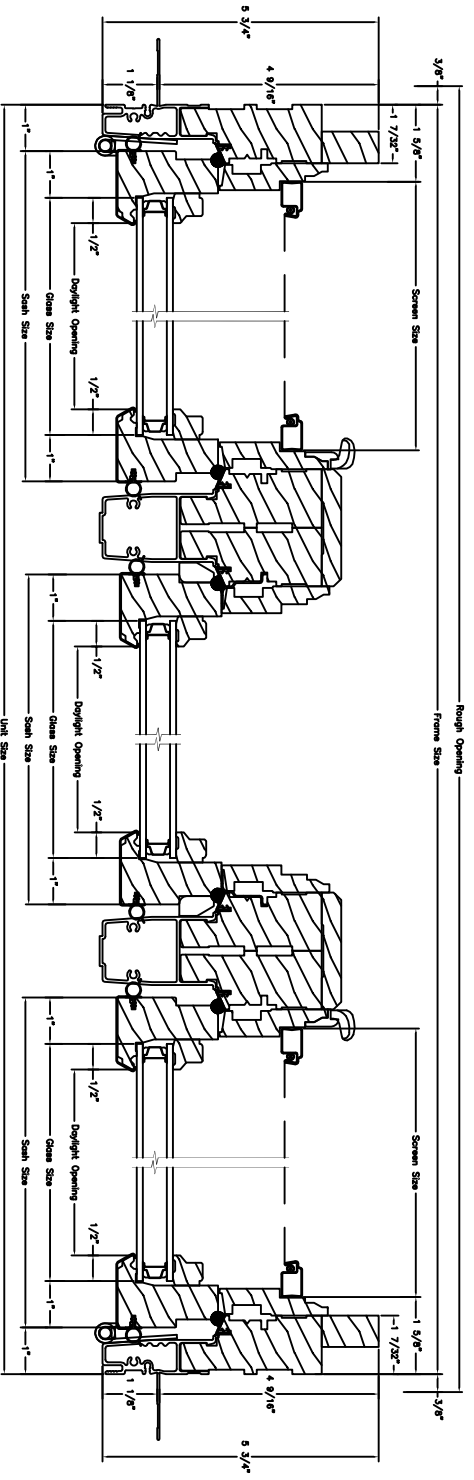

Horizontal Section

VERTICAL SECTION
EXTRUDED SASH IMPACT
OPERATING UNIT

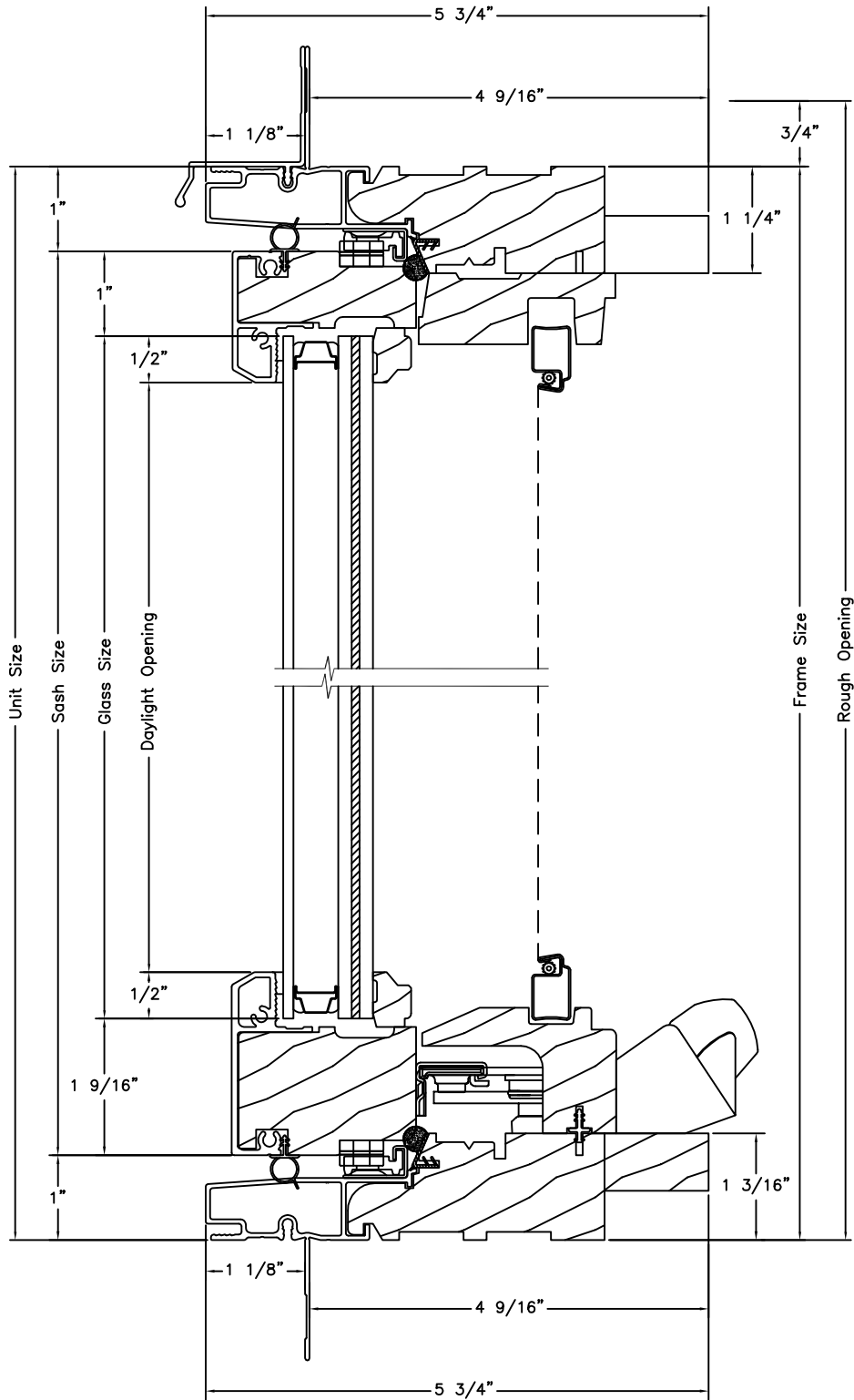

HORIZONTAL SECTION
EXTRUDED SASH IMPACT
OPERATING UNIT

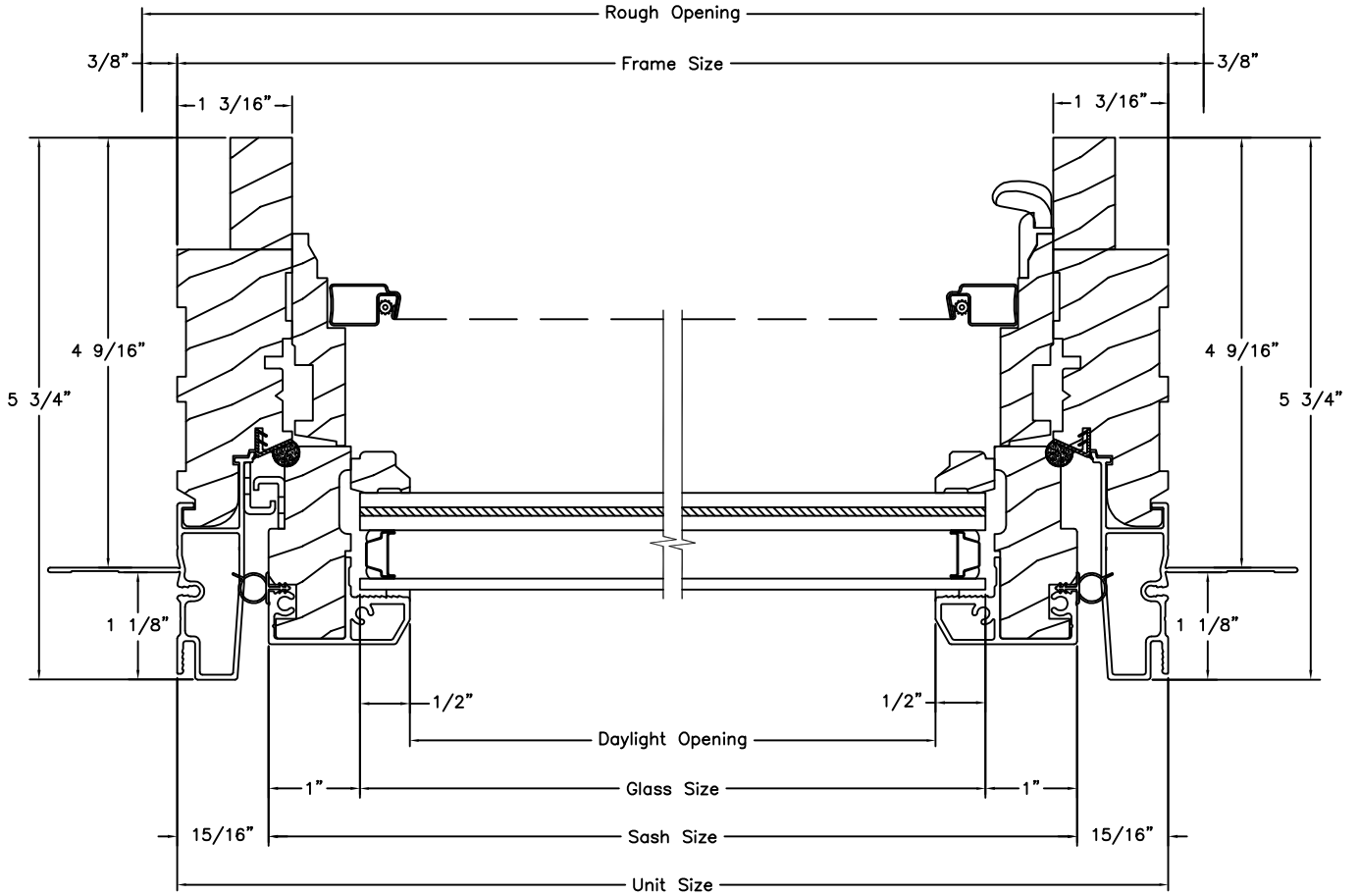

VERTICAL SECTION
EXTENDED HALF ROUND UNIT

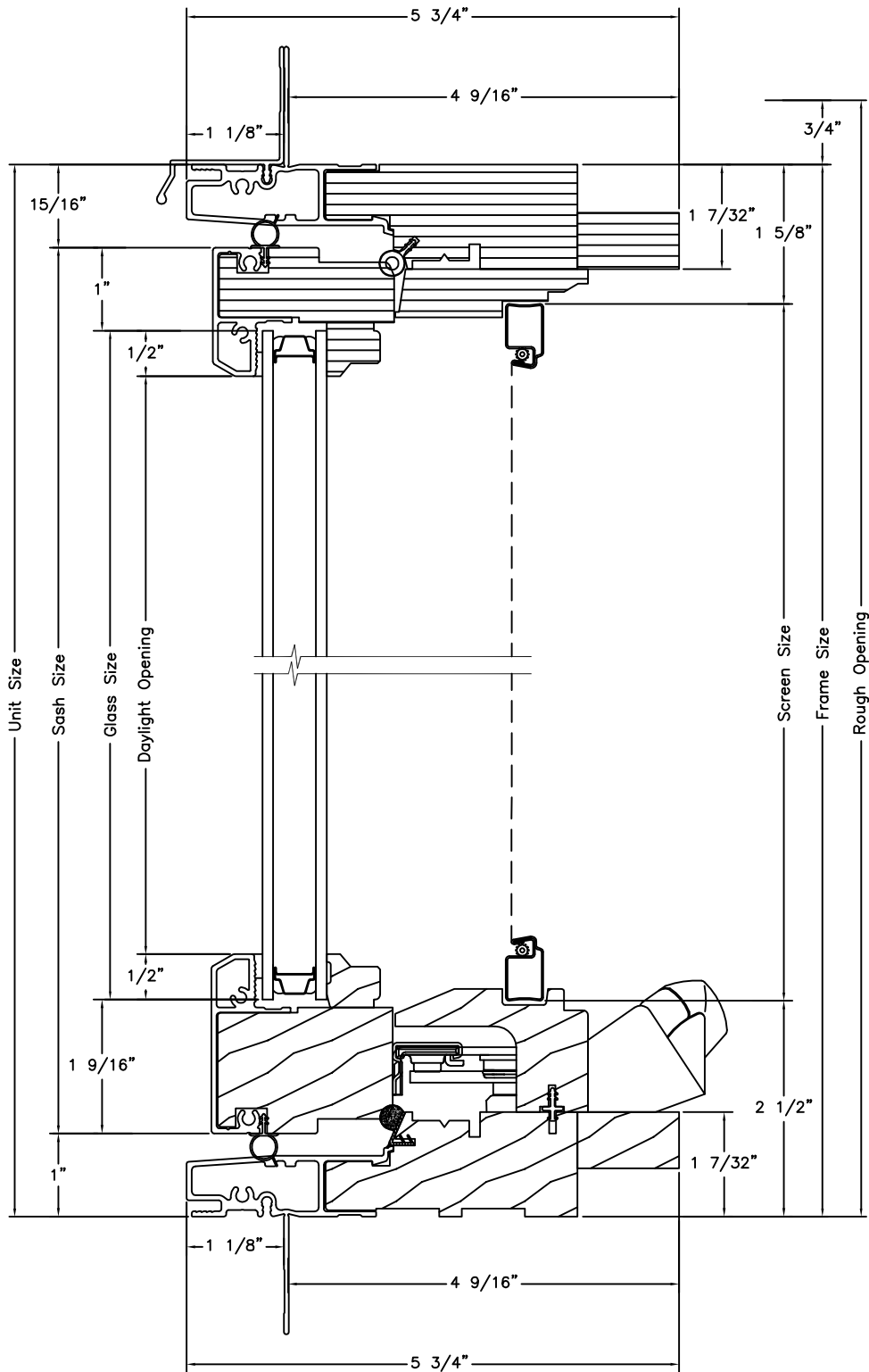

HORIZONTAL SECTION
EXTENDED HALF ROUND

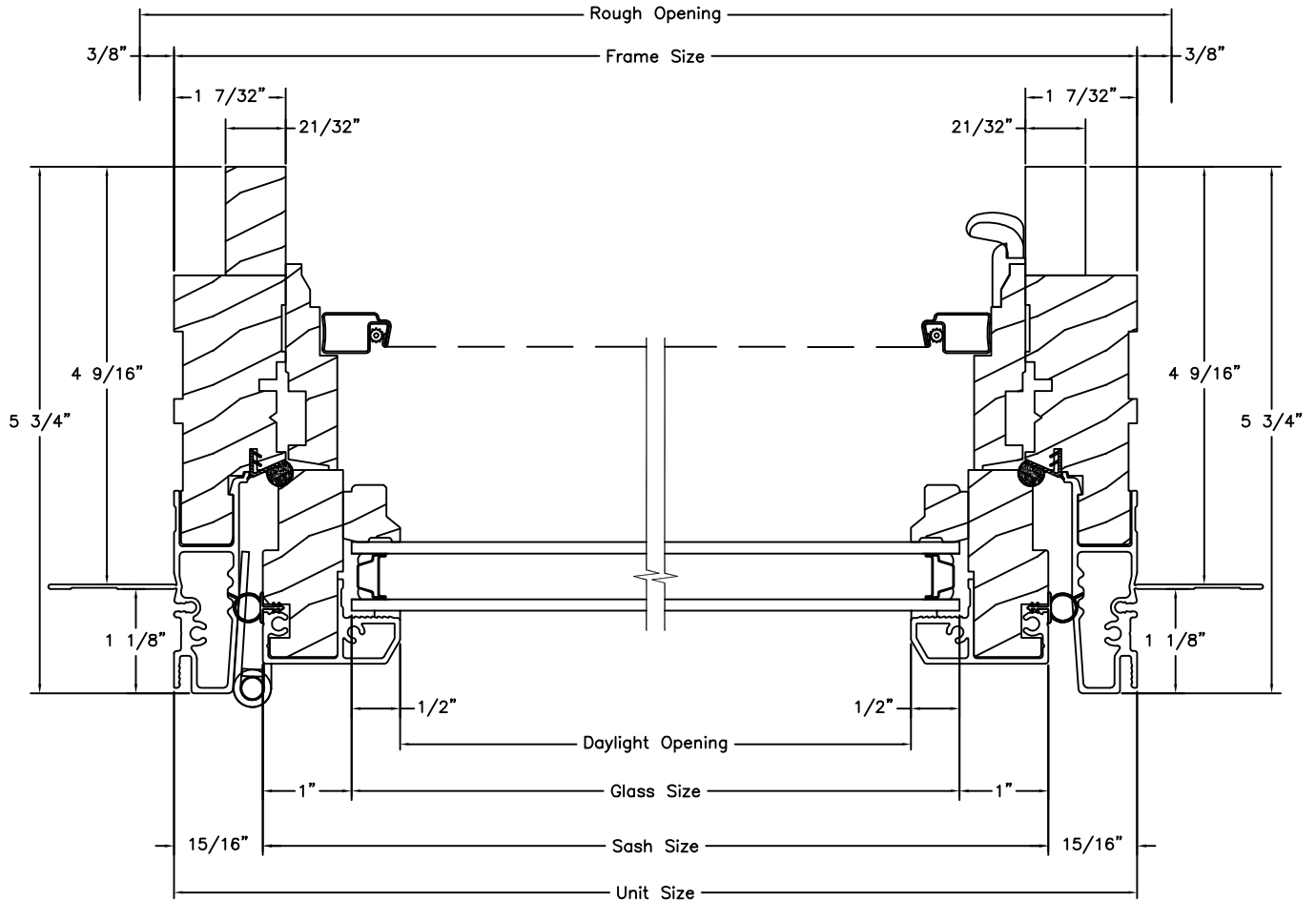

BAY WINDOW HORIZONTAL
SPECIFICATION TABLES
TABLES

30° BAY

	A	F	B	C	E	D	G	
Flanker Width	Center Width	Rough Opening	Unit Width	Overall Projection	Projection Exterior Wall	Seating Depth	Outside Mull To Mull	Outside Mull To Unit
18	18	52 3/8	53 11/16	14 13/16	10 1/4	11 7/16	19 13/16	20 3/8
18	36	70 3/8	71 11/16	14 13/16	10 1/4	11 7/16	37 13/16	20 3/8
18	42	76 3/8	77 11/16	14 13/16	10 1/4	11 7/16	43 13/16	20 3/8
18	48	82 3/8	83 11/16	14 13/16	10 1/4	11 7/16	49 13/16	20 3/8
18	60	94 3/8	95 11/16	14 13/16	10 1/4	11 7/16	61 13/16	20 3/8
18	72	106 3/8	107 11/16	14 13/16	10 1/4	11 7/16	73 13/16	20 3/8

45° BAY

	A	F	B	C	E	D	G	
Flanker Width	Center Width	Rough Opening	Unit Width	Overall Projection	Projection Exterior Wall	Seating Depth	Outside Mull To Mull	Outside Mull To Unit
18	18	46 13/16	49 13/16	19 5/16	14 13/16	15 15/16	20 13/16	20 7/8
18	36	64 13/16	67 13/16	19 5/16	14 13/16	15 15/16	38 13/16	20 7/8
18	42	70 13/16	73 13/16	19 5/16	14 13/16	15 15/16	44 13/16	20 7/8
18	48	76 13/16	79 13/16	19 5/16	14 13/16	15 15/16	50 13/16	20 7/8
18	60	88 13/16	91 13/16	19 5/16	14 13/16	15 15/16	62 13/16	20 7/8
18	72	100 13/16	103 13/16	19 5/16	14 13/16	15 15/16	74 13/16	20 7/8

24	24	68 13/16	70 1/16	17 13/16	13 1/4	14 7/16	25 13/16	26 3/8
24	36	80 13/16	82 1/16	17 13/16	13 1/4	14 7/16	37 13/16	26 3/8
24	42	86 13/16	88 1/16	17 13/16	13 1/4	14 7/16	43 13/16	26 3/8
24	48	92 13/16	94 1/16	17 13/16	13 1/4	14 7/16	49 13/16	26 3/8
24	60	104 13/16	106 1/16	17 13/16	13 1/4	14 7/16	61 13/16	26 3/8
24	72	116 13/16	118 1/16	17 13/16	13 1/4	14 7/16	73 13/16	26 3/8

24	24	61 5/16	64 5/16	23 9/16	19 1/32	20 3/16	26 13/16	26 7/8
24	36	73 5/16	76 5/16	23 9/16	19 1/32	20 3/16	38 13/16	26 7/8
24	42	79 5/16	82 5/16	23 9/16	19 1/32	20 3/16	44 13/16	26 7/8
24	48	85 5/16	88 5/16	23 9/16	19 1/32	20 3/16	50 13/16	26 7/8
24	60	97 5/16	100 5/16	23 9/16	19 1/32	20 3/16	62 13/16	26 7/8
24	72	109 5/16	112 5/16	23 9/16	19 1/32	20 3/16	74 13/16	26 7/8

28	28	79 11/16	81	19 13/16	15 1/4	16 7/16	29 13/16	30 3/8
28	36	87 11/16	89	19 13/16	15 1/4	16 7/16	37 13/16	30 3/8
28	42	93 11/16	95	19 13/16	15 1/4	16 7/16	43 13/16	30 3/8
28	48	99 11/16	101	19 13/16	15 1/4	16 7/16	49 13/16	30 3/8
28	60	111 11/16	113	19 13/16	15 1/4	16 7/16	61 13/16	30 3/8
28	72	123 11/16	125	19 13/16	15 1/4	16 7/16	73 13/16	30 3/8

28	28	71	73 31/32	26 3/8	21 7/8	23	30 13/16	30 7/8
28	36	79	81 31/32	26 3/8	21 7/8	23	38 13/16	30 7/8
28	42	85	87 31/32	26 3/8	21 7/8	23	44 13/16	30 7/8
28	48	91	93 31/32	26 3/8	21 7/8	23	50 13/16	30 7/8
28	60	103	105 31/32	26 3/8	21 7/8	23	62 13/16	30 7/8
28	72	115	117 31/32	26 3/8	21 7/8	23	74 13/16	30 7/8

4 9/16 and 6 9/16 WALL APPLICATION
The tables above reflect a 4 9/16" wall application. To convert to 6 9/16" wall application add 2" to the figures in the columns which show an asterisk (*), B and E.
ROUGH OPENING data reflects FRAME + 3/4".

BAY WINDOW HORIZONTAL SPECIFICATION TABLES SECTIONS

BOOKCODE NOTE:

CCY183648-30

Degree of Bay Window
 Frame Height
 Center Frame Width
 Flanker Frame Width

EXTREME PERIMETER
 Extreme Perimeter is the distance around the face of the bay, beginning at the exterior sheathing and continuing around the assembly along the extreme face of the basic unit frame.

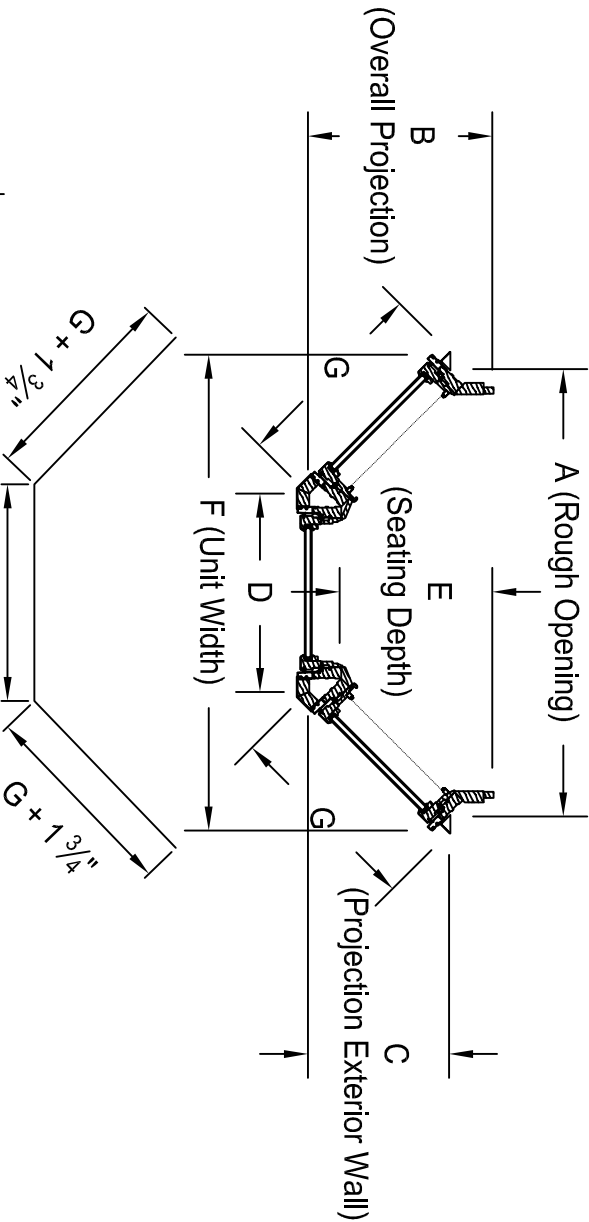
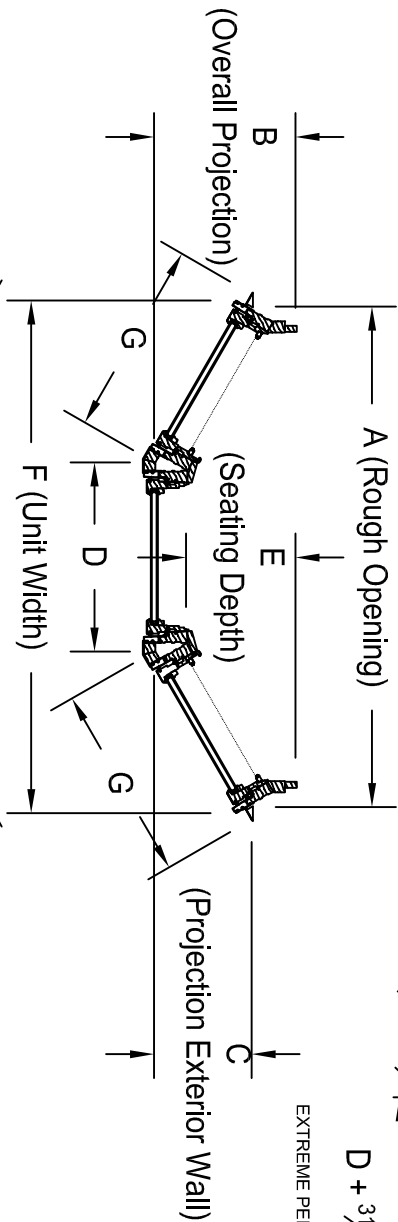

BOW WINDOW HORIZONTAL
SPECIFICATION TABLES
4-WIDE

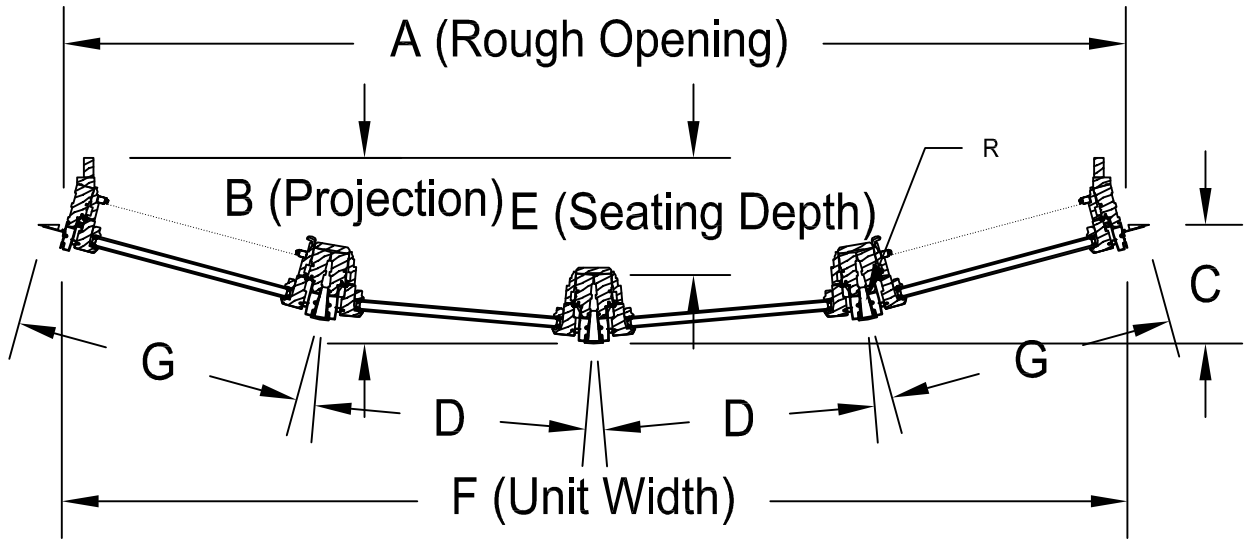

4 WIDE BOW									
Flanker Width	A Rough Opening	F Unit Width	B Overall Projection*	C Projection Exterior Wall	E Seating Depth*	D Outside Mull To Mull	G Outside Mull To Unit	R Radius	
18	72 7/8	72 32/32	11 13/32	6 27/32	8	18 19/32	19 25/32	106 1/2	
24	96 7/16	96 1/2	13 15/32	8 29/32	10 3/32	24 19/32	25 25/32	140 3/8	
28	112 1/8	112 3/16	14 7/8	10 5/16	11 15/32	28 19/32	29 25/32	163 1/16	

EXTREME PERIMETER

Extreme Perimeter is the distance around the face of the bow, beginning at the exterior sheathing and continuing around the assembly along the extreme face of the frame.

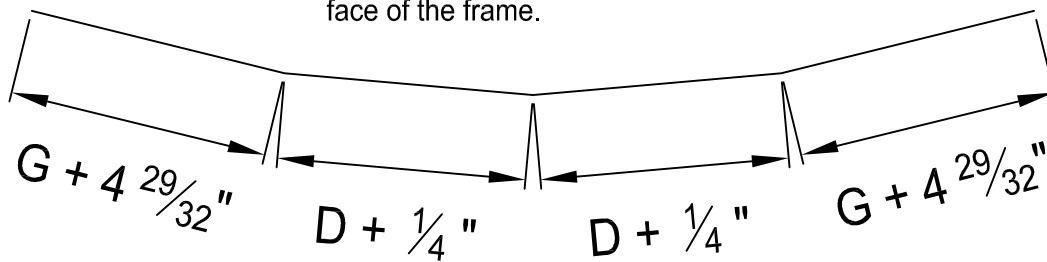

EXTREME PERIMETER

BOW WINDOW HORIZONTAL
SPECIFICATION TABLES
5-WIDE

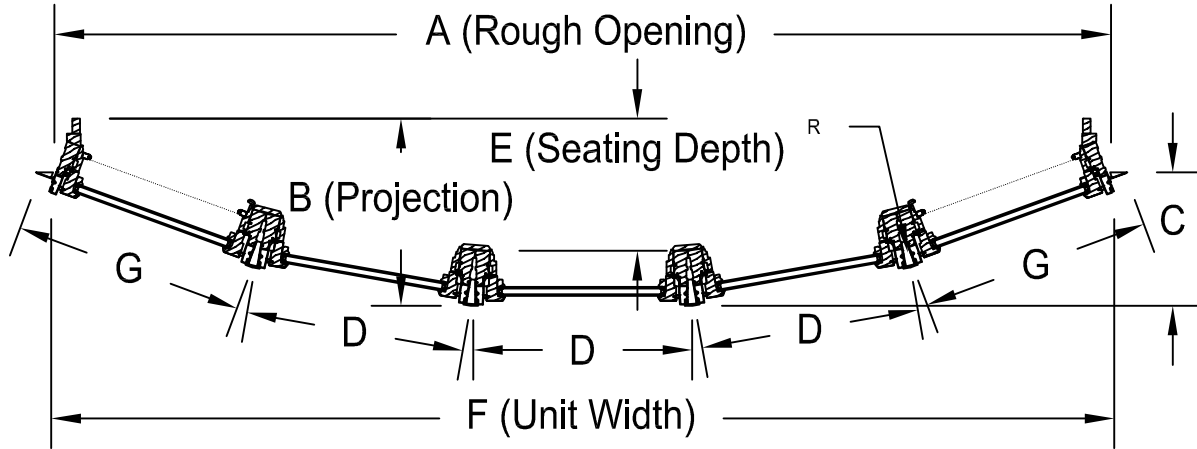

5 WIDE BOW									
Flanker Width	A Rough Opening	F Unit Width	B * Overall Projection	C Projection Exterior Wall	E * Seating Depth	D Outside Mull To Mull	G Outside Mull To Unit	R Radius	
18	89 15/16	90 3/8	14 5/8	10 1/16	11 7/32	18 19/32	19 25/32	106 1/2	
24	119	119 7/16	17 11/16	13 1/8	14 5/16	24 19/32	25 25/32	140 15/16	
28	138 3/8	138 27/32	19 3/4	15 3/16	16 3/8	28 19/32	29 25/32	163 1/16	

EXTREME PERIMETER

Extreme Perimeter is the distance around the face of the bow, beginning at the exterior sheathing and continuing around the assembly along the extreme face of the frame.

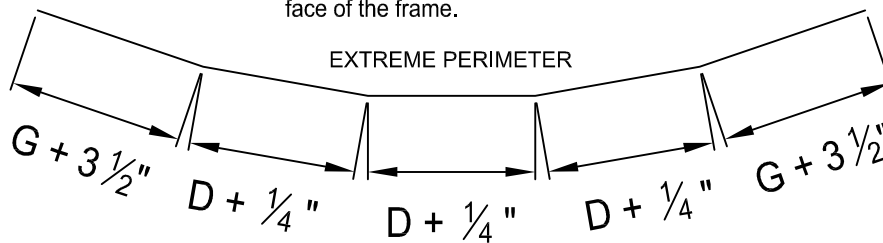

RADIUS NOTE: The Radius of a Bow Window is referenced from the interior of the Nailing Flange.

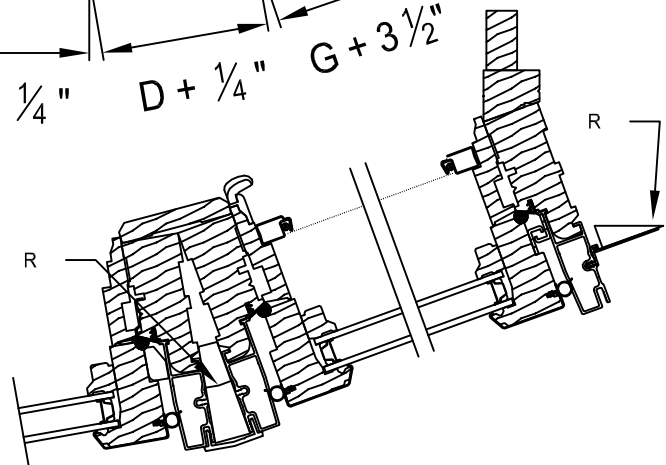

BOW WINDOW HORIZONTAL
SPECIFICATION TABLES
6-WIDE

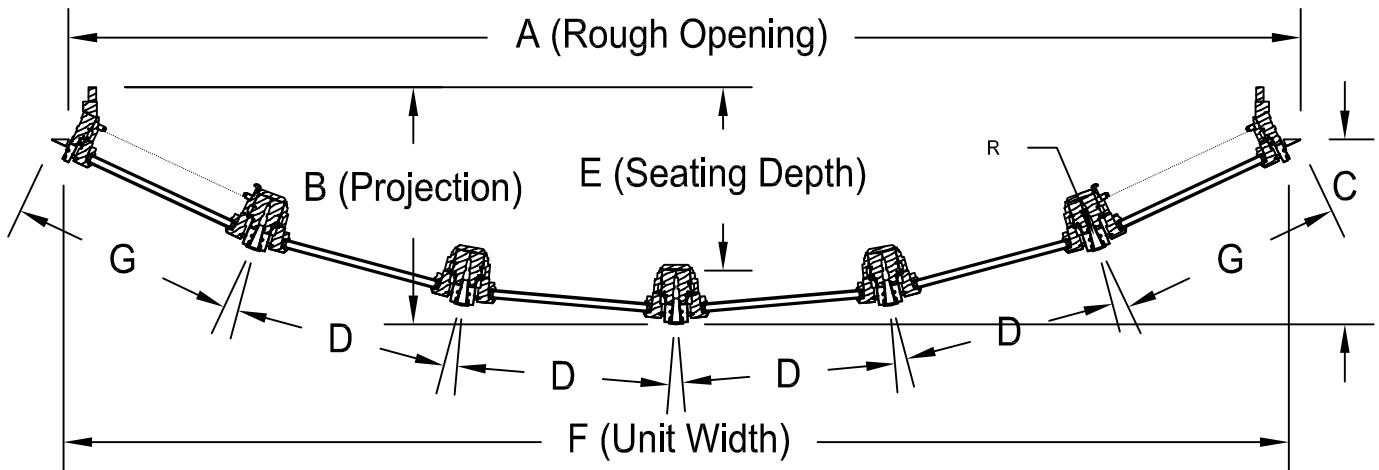

6 WIDE BOW									
Flanker Width	A Rough Opening	F Unit Width	B* Overall Projection	C Projection Exterior Wall	E* Seating Depth	D Outside Mull To Mull	G Outside Mull To Unit	R Radius	
18	106 1/4	107 1/16	19 3/8	14 13/16	16	18 19/32	19 25/32	106 1/2	
24	140 5/8	141 15/32	24	19 7/16	20 5/8	24 19/32	25 25/32	140 15/16	
28	163 5/8	164 7/16	27 1/16	22 1/2	23 11/16	28 19/32	29 25/32	163 1/16	

4 9/16 and 6 9/16 WALL APPLICATION

The tables above reflect a 4 9/16" wall application. To convert to 6 9/16" wall application add 2" to the figures in the columns which show an asterisk (*), B and E.

EXTREME PERIMETER

Extreme Perimeter is the distance around the face of the bow, beginning at the exterior sheathing and continuing around the assembly along the extreme face of the frame.

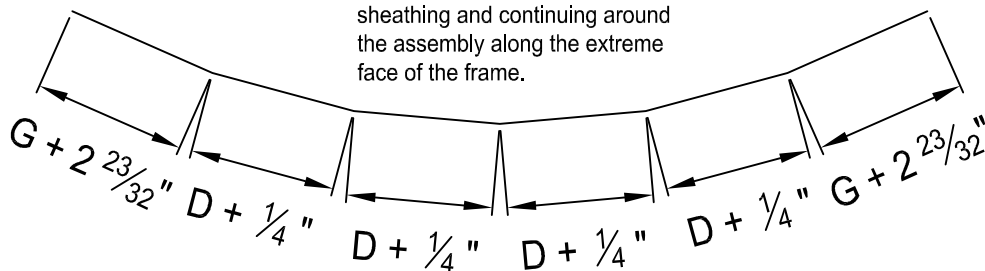

EXTREME PERIMETER

BAY & BOW WINDOW ROUGH OPENINGS

BAY & BOW WINDOW TRIM OPTIONS

The standard offering for clad bay & bow windows is 'frame only' and brickmould and sillnose. Other trim options subject to approval. Rough & Masonry openings remain consistent with all trim options.

VERTICAL ROUGH OPENING

Rough Opening typical for all Units

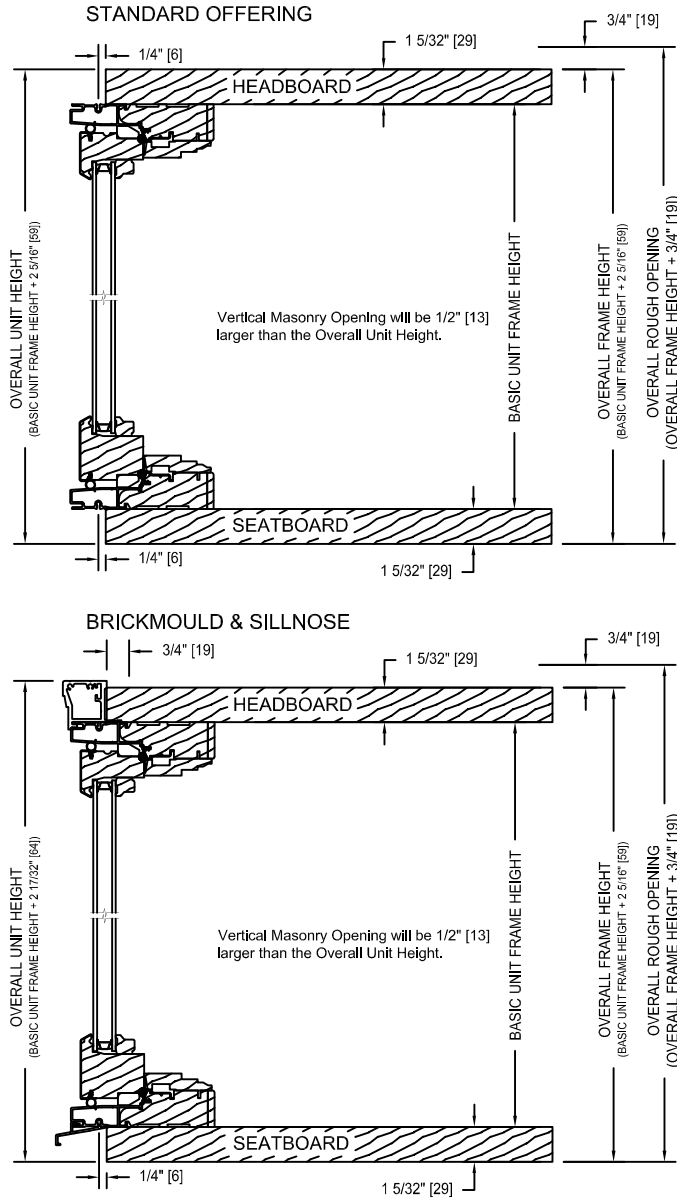

HORIZONTAL ROUGH OPENING

Rough Opening typical for all Units

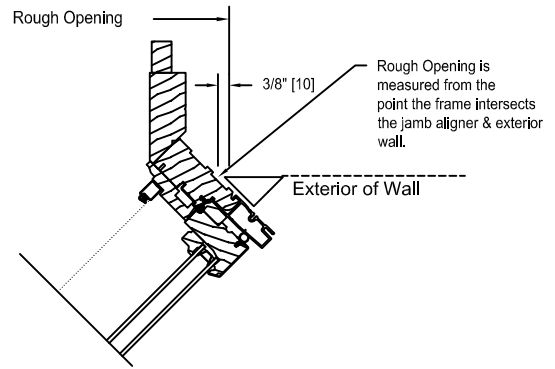

30° & 45° BAYS
45° Bay Shown without trim

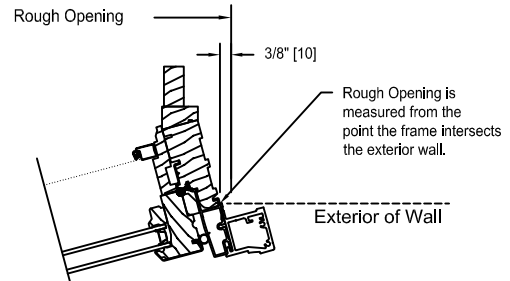

4, 5 & 6 WIDE BOWS
4 Wide Bow Shown with Brickmould Shown

VERTICAL SECTION
30° & 45 ANGLE BAY UNIT

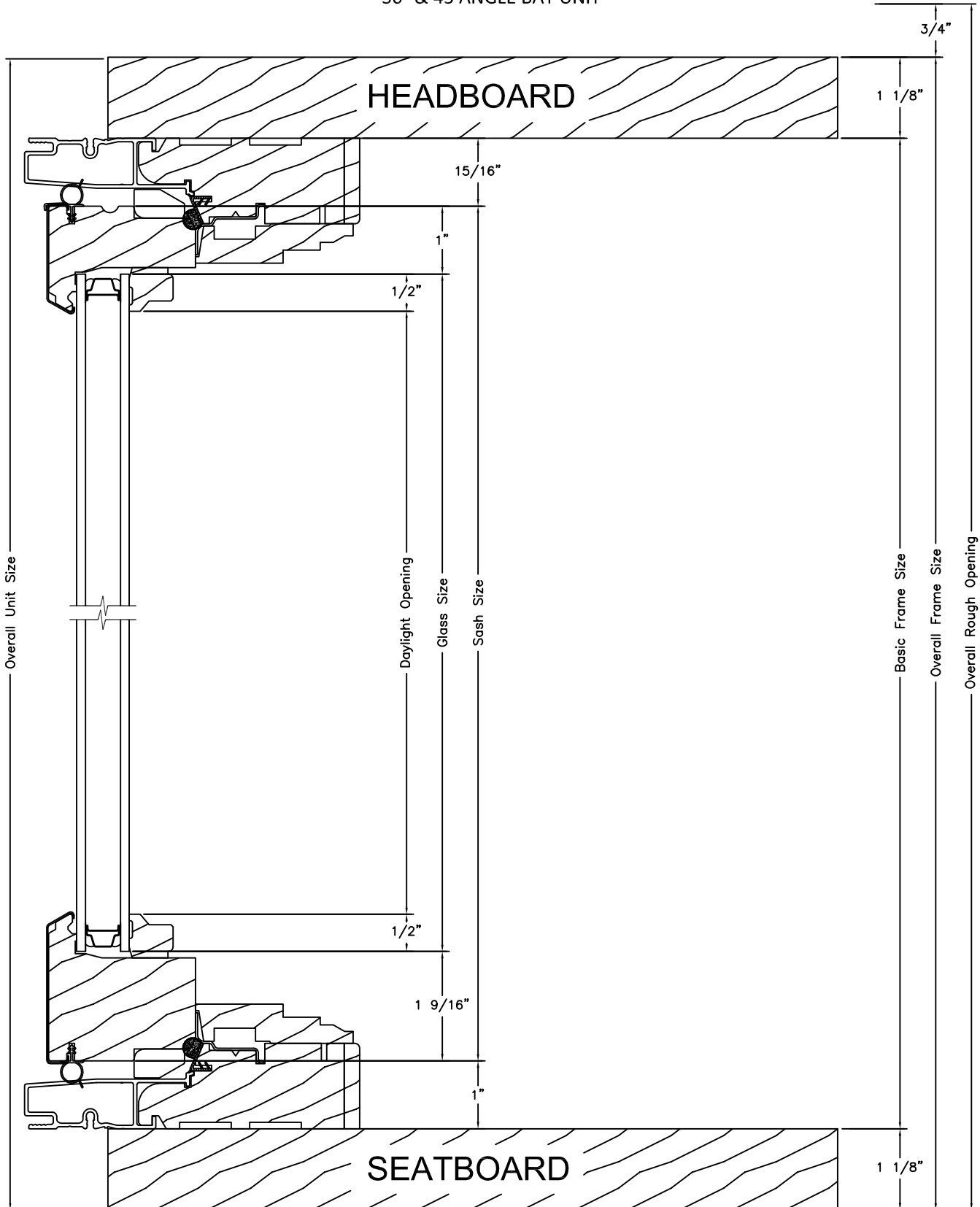

VERTICAL SECTION
30° & 45 ANGLE BAY UNIT
WITH BRICKMOULD

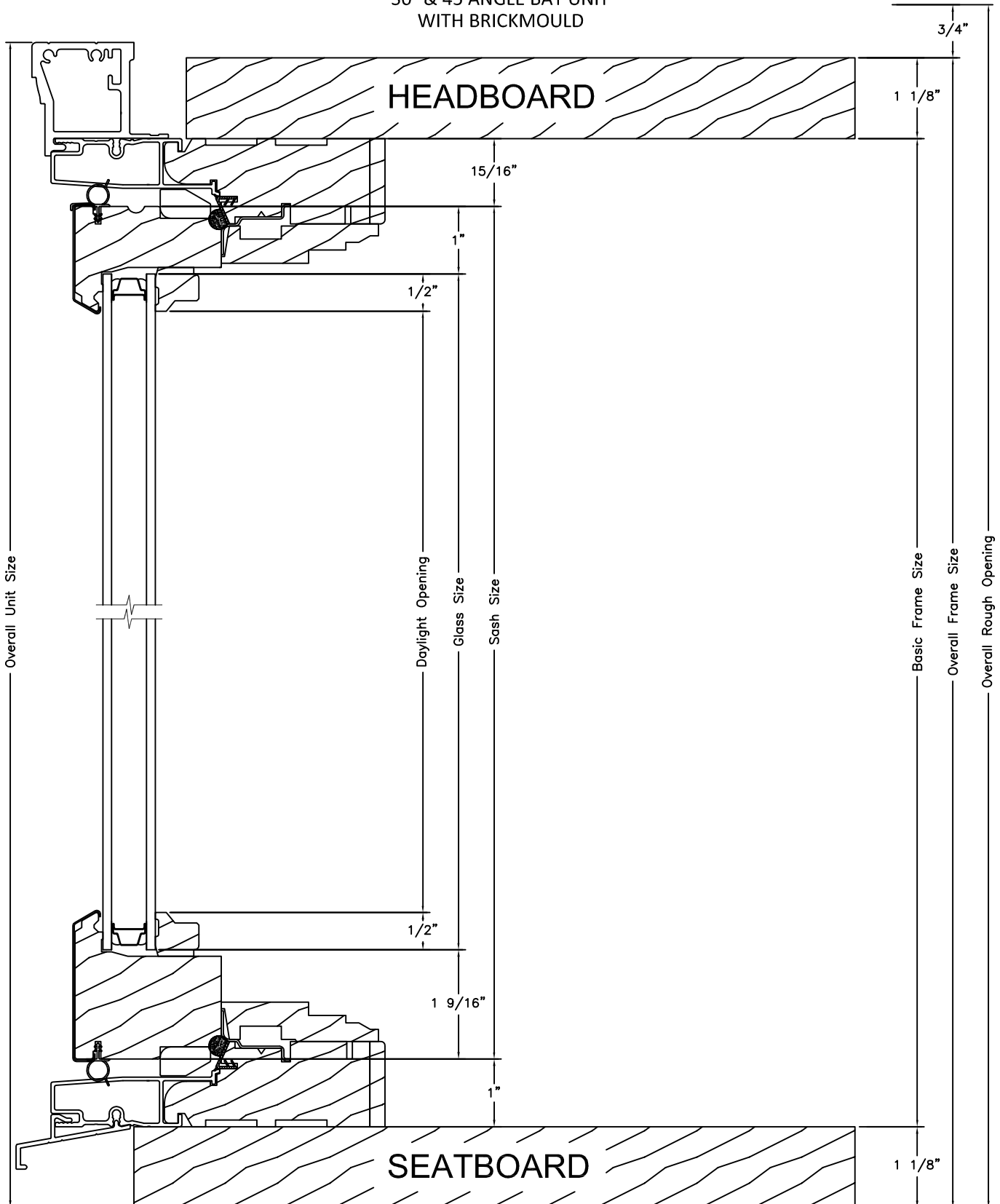

HORIZONTAL SECTION
30° ANGLE BAY UNIT

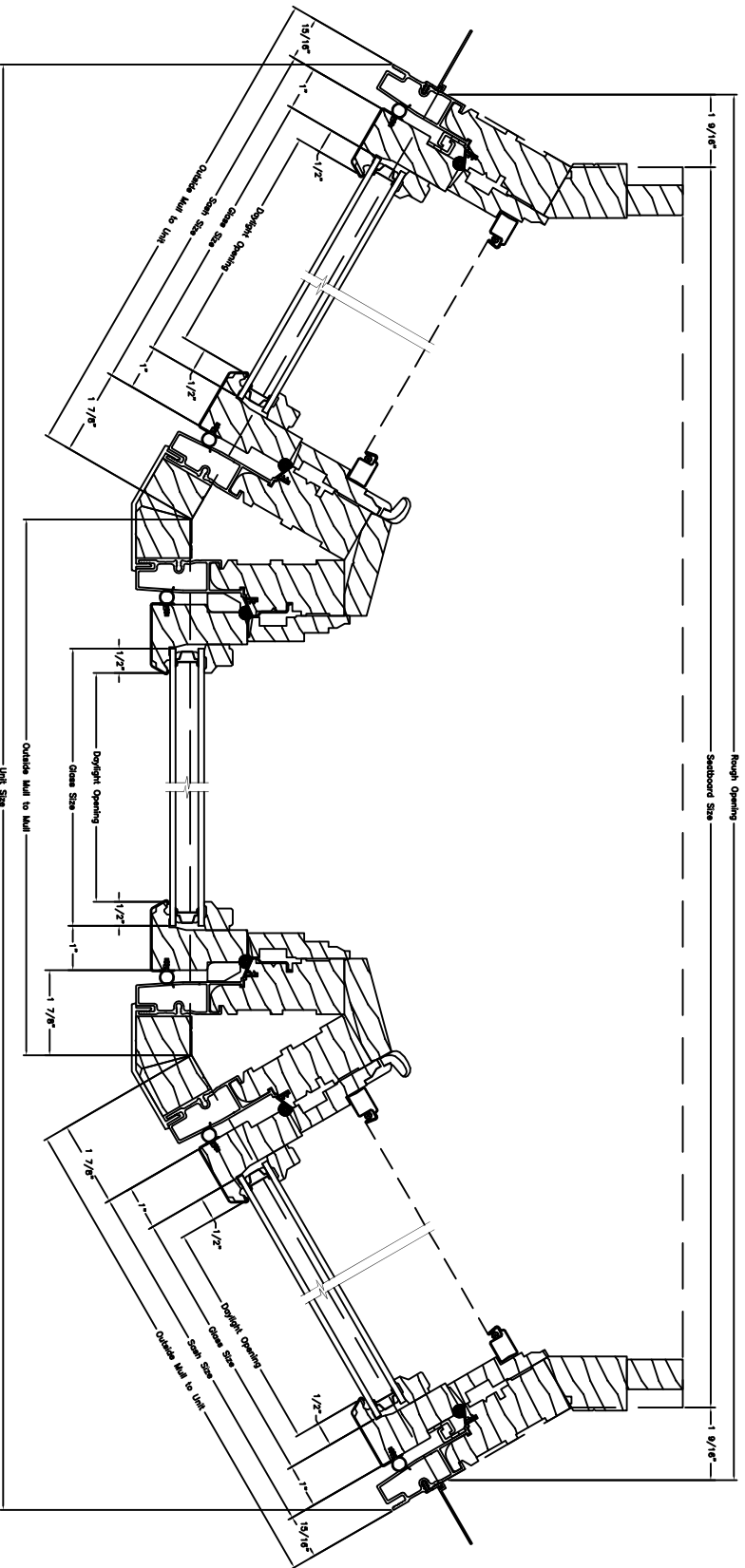

**HORIZONTAL SECTION
45° ANGLE BAY UNIT**

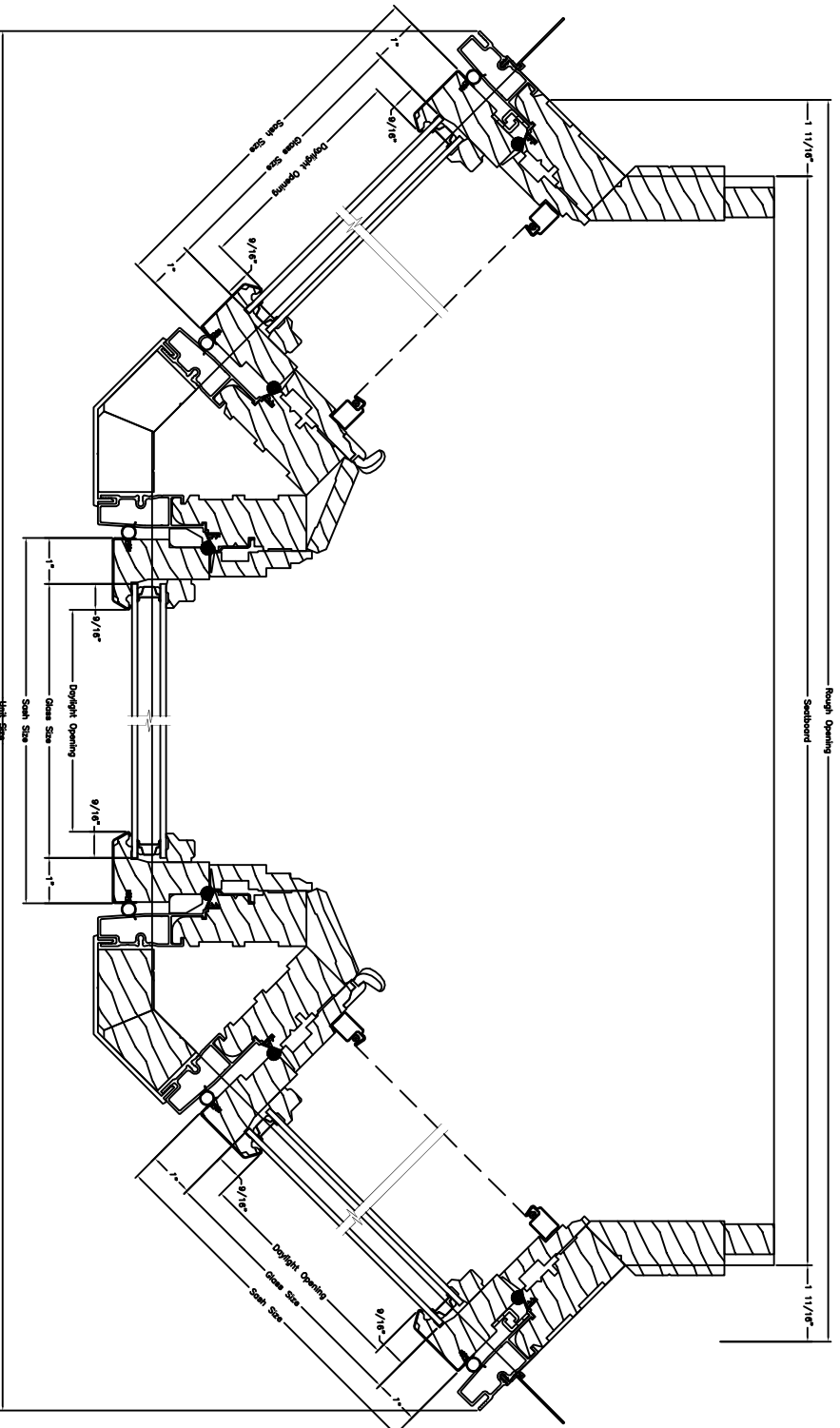

VERTICAL SECTION
BOW UNITS

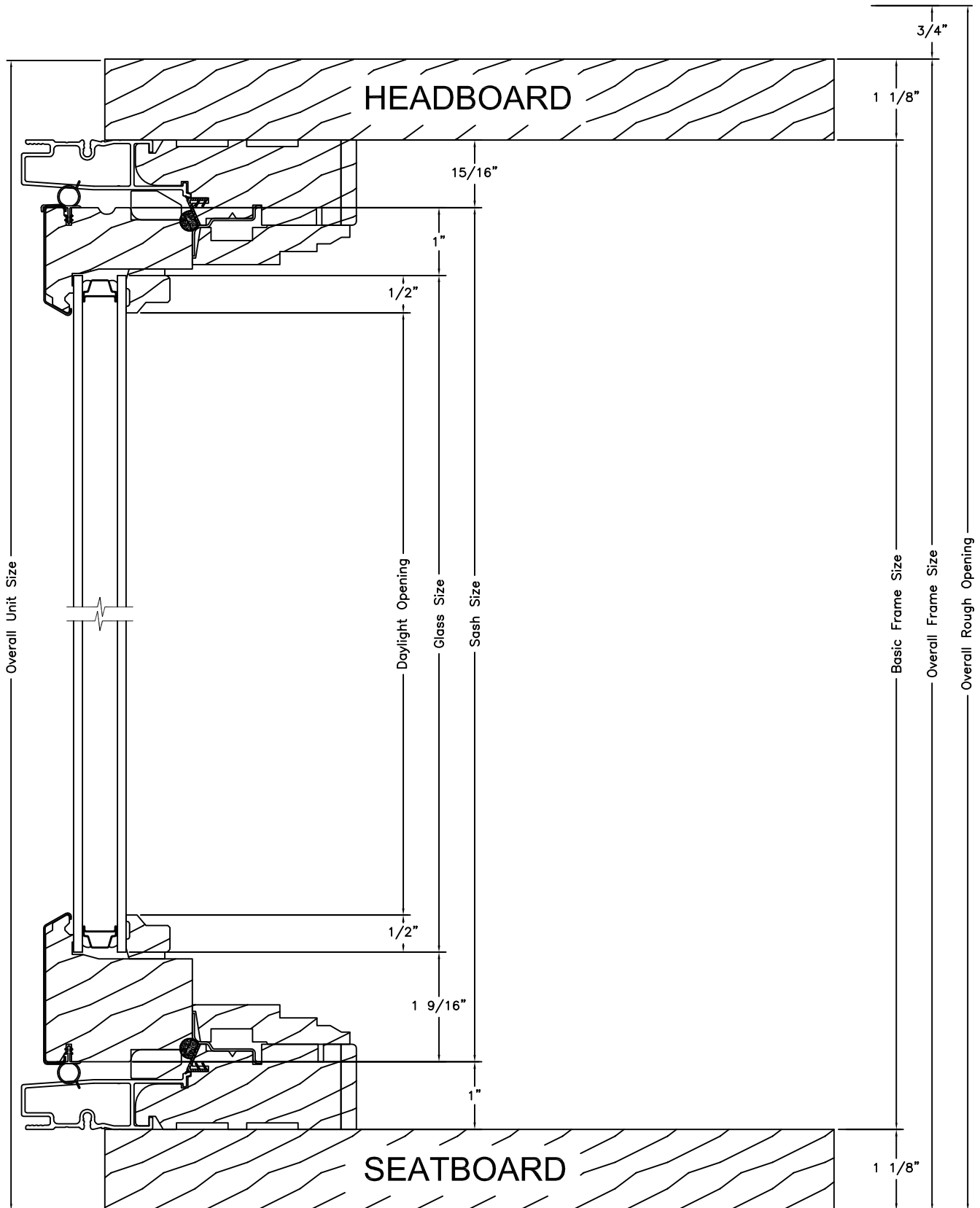

VERTICAL SECTION
BOW UNITS
WITH BRICKMOULD

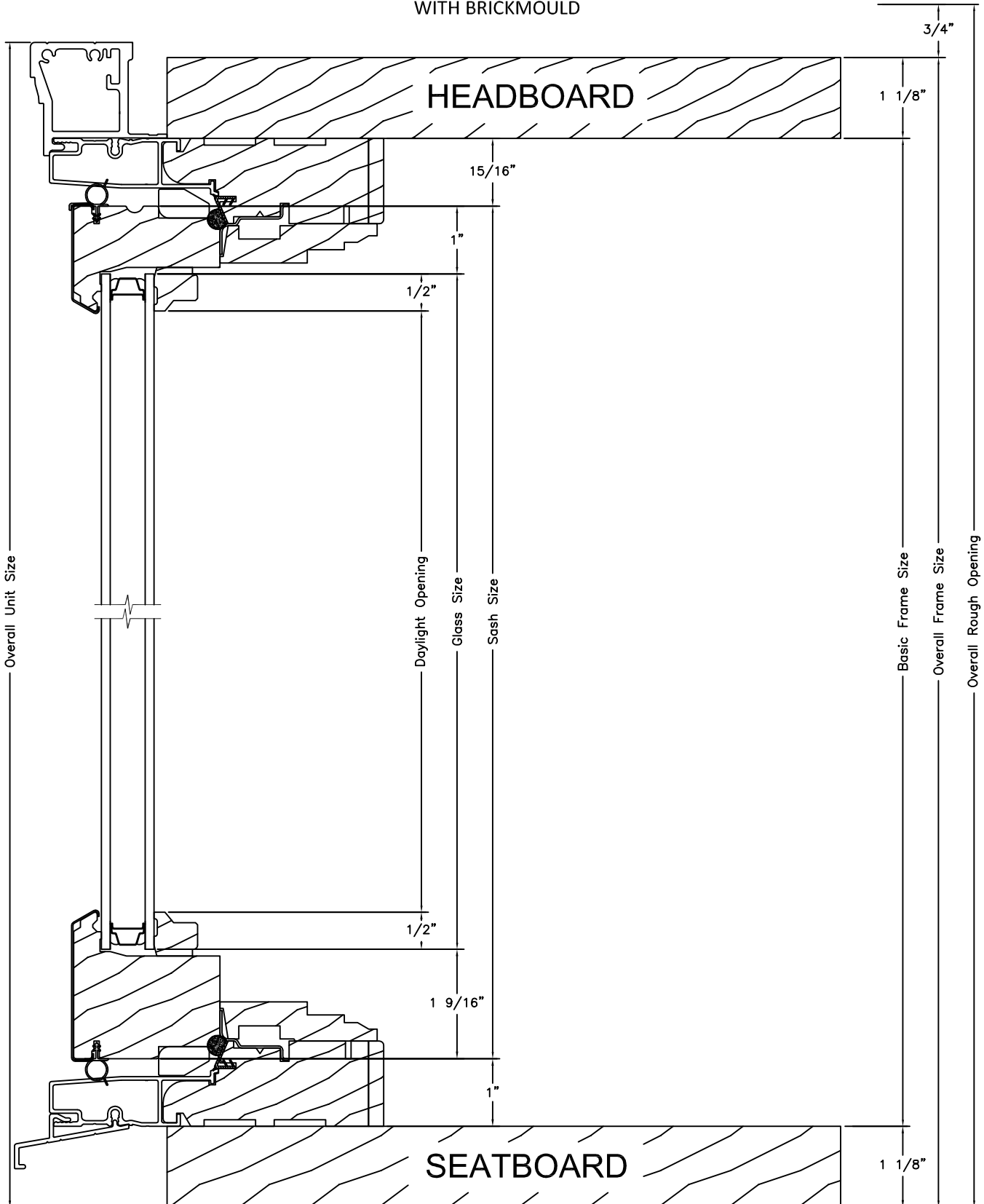

HORIZONTAL SECTION
BOW UNITS
4-WIDE

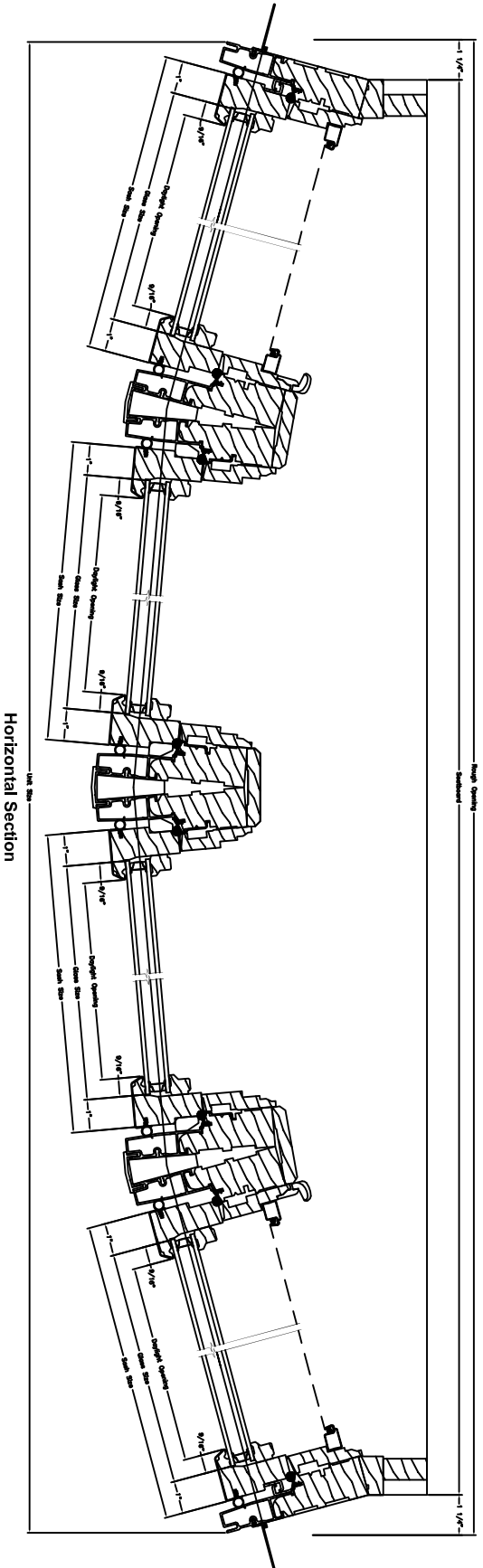

HORIZONTAL SECTION
BOW UNITS
5-WIDE

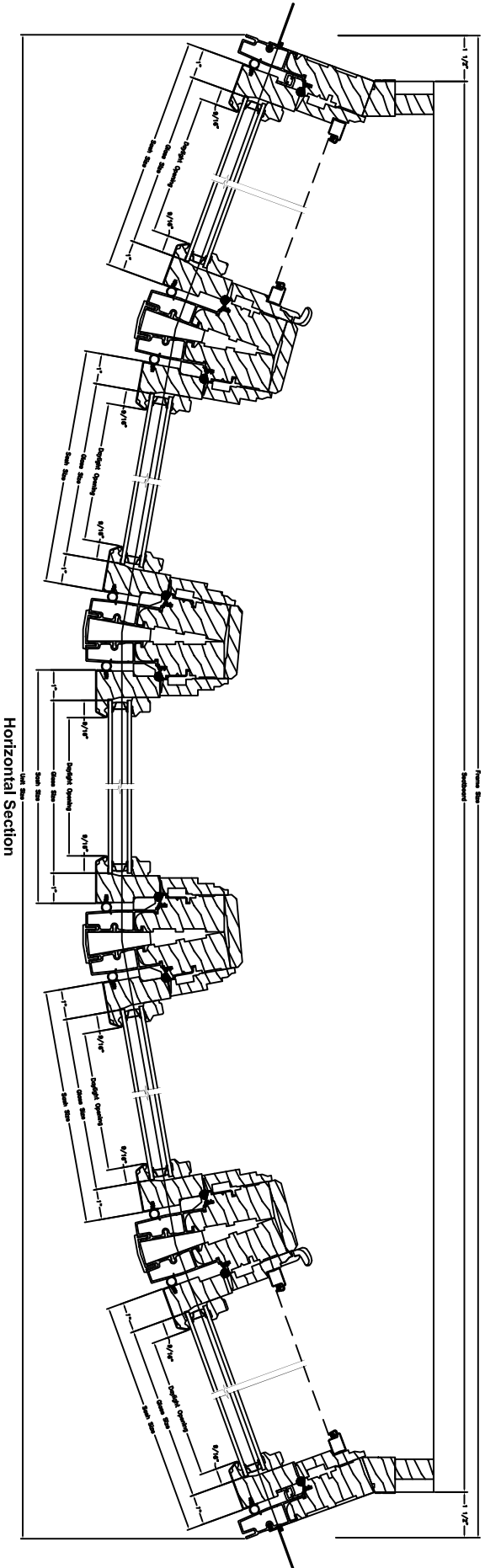

**HORIZONTAL SECTION
BOW UNITS
6-WIDE**

