

**TABLE OF CONTENTS**

**3/4 VIEW**

Elevations: 1/8" Scale

180	203	442	1322
200	402	1260	5506
201	408	1265	5509
202	423	1315	5512

Decorative Hardware

Exterior Casing Options

Exterior/Interior Corner Block Options

Decorative Glass Options

Decorative Grilles - 1260

**Section Details**

180	203	442	1322
200	402	1260	5506
201	408	1265	5509
202	423	1315	5512

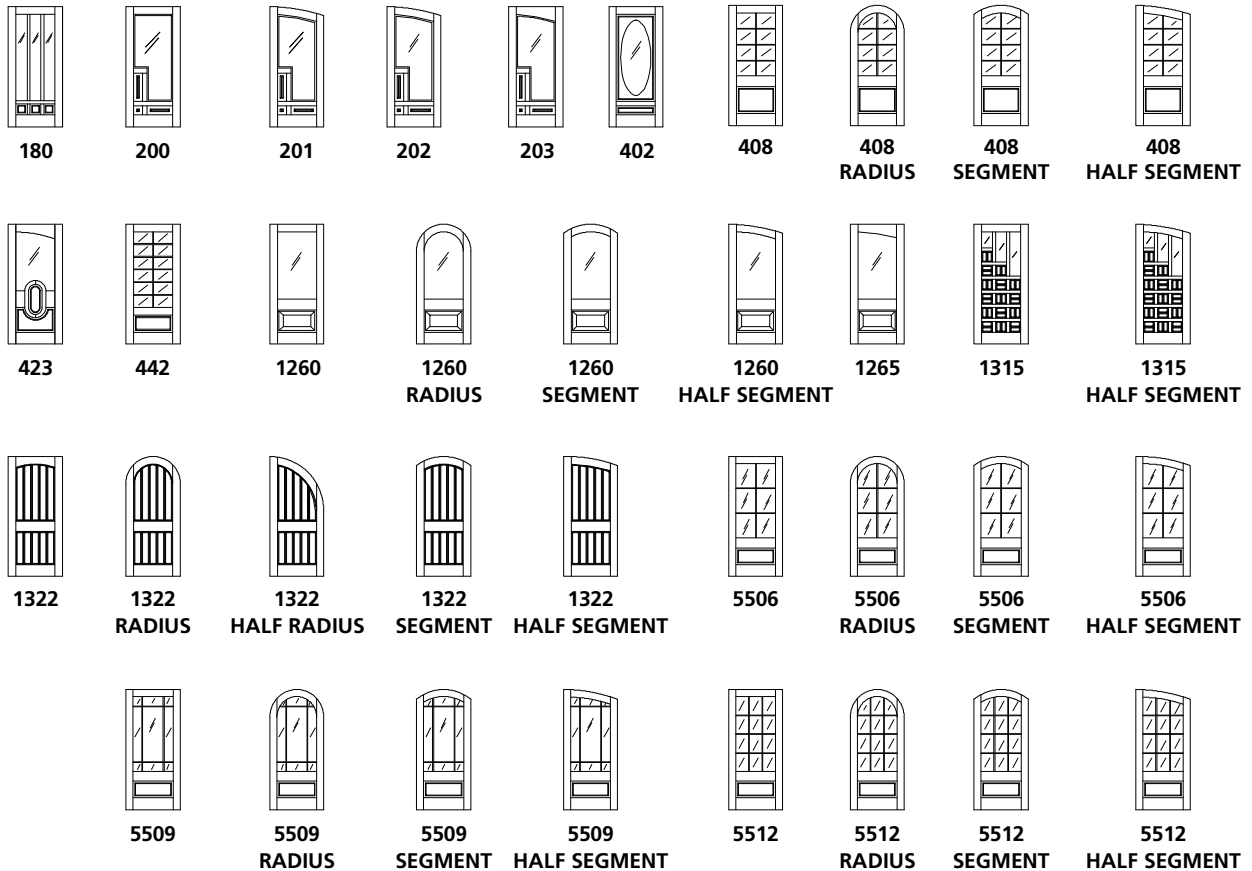

### ELEVATION NOTES

Door Size = Book Size Before Prefit  
 Daylight Opening (DLO) = Visible Glass  
 Values in brackets [ ] are millimeter conversions.

### DOOR CROSS-SECTION

Moulding Profile = 116  
 Panel Profile = 45 Degree  
 See 180 Cross Section sheet for more detail.

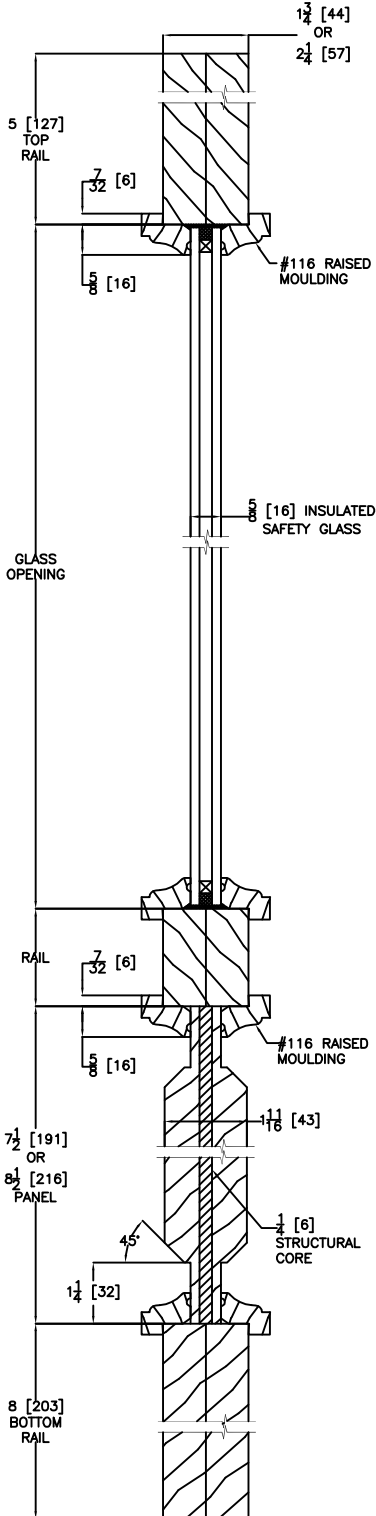

**Door Size**  
 Daylight Opening

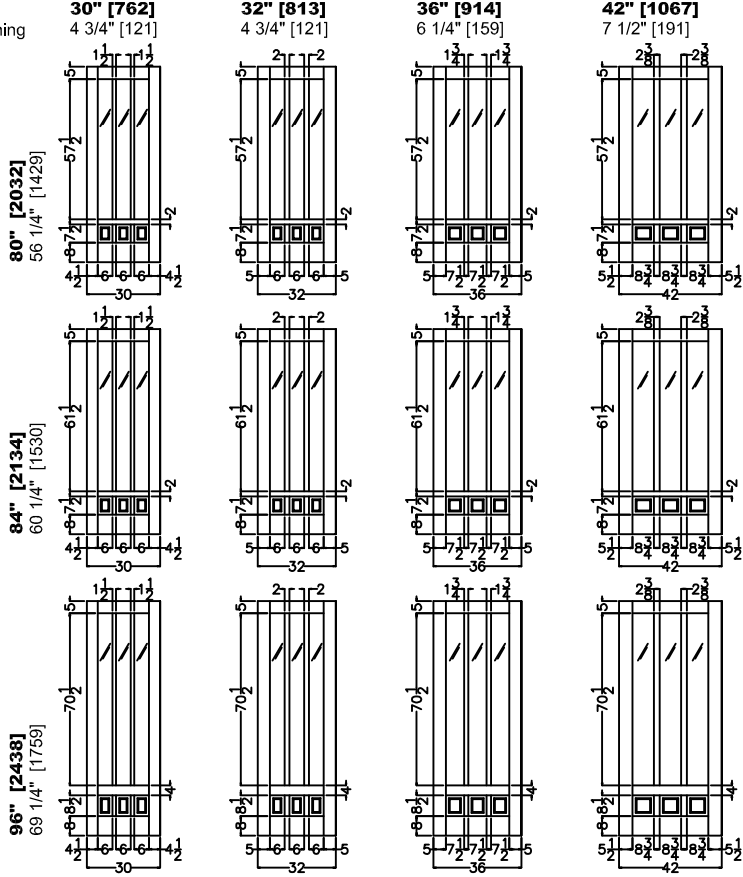

**Sidelight Size**  
 Daylight Opening

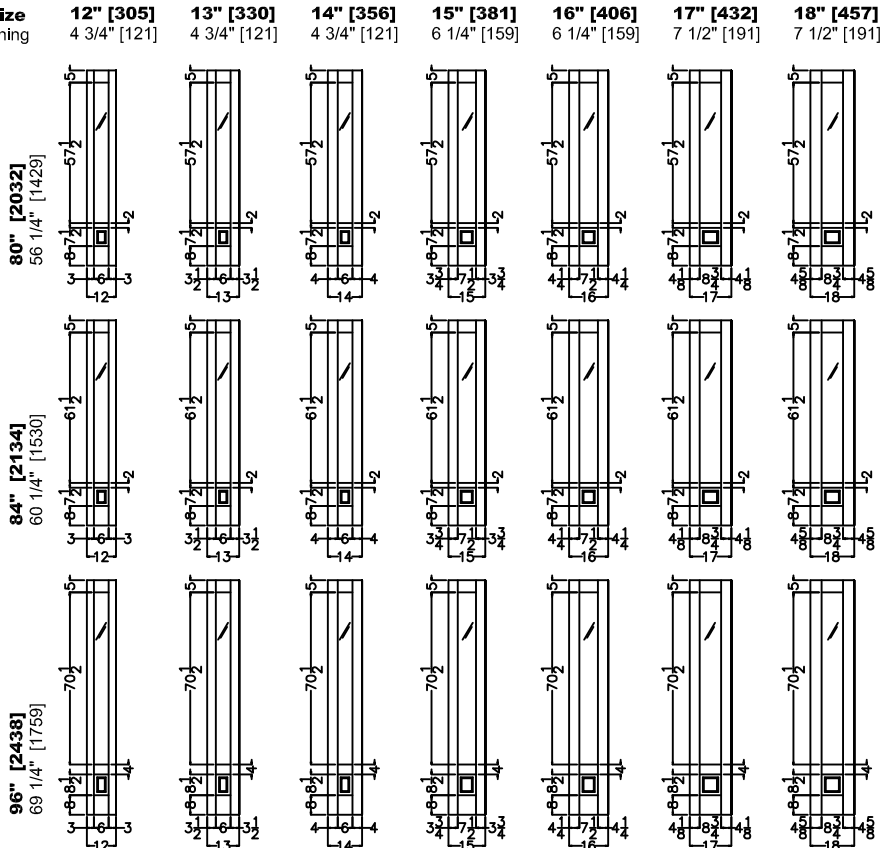

VERTICAL DOOR/SIDELIGHT CROSS SECTION  
 Insulated Glass

### ELEVATION NOTES

Door Size = Book Size Before Prefit  
 Daylight Opening (DLO) = Visible Glass  
 Values in brackets [ ] are millimeter conversions.

### DOOR CROSS-SECTION

Moulding Profile = 112  
 Panel Profile = Double Hip  
 See 200 Cross Section sheet for more detail.

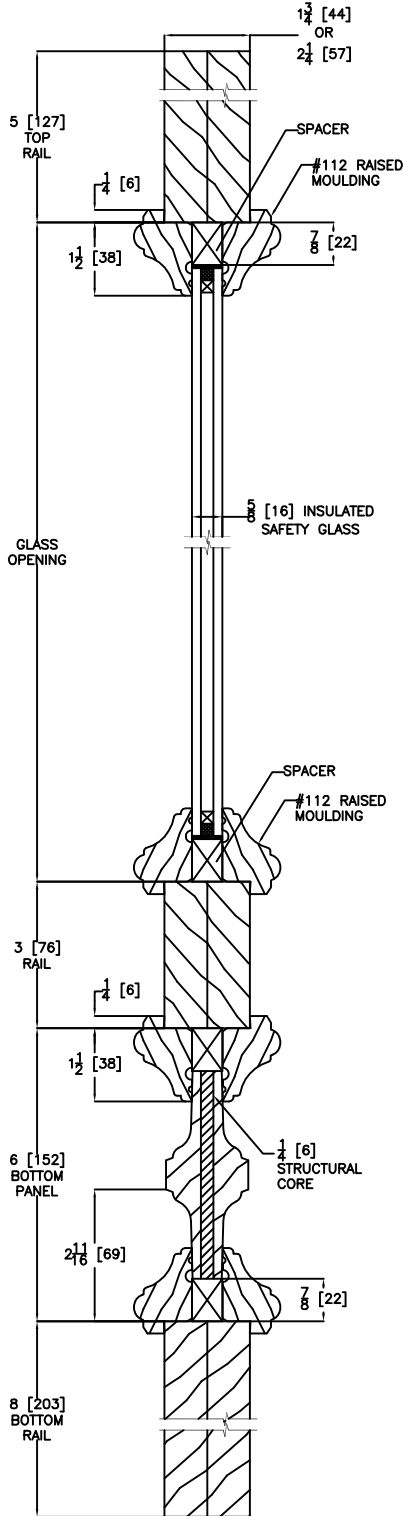

VERTICAL DOOR/SIDELIGHT CROSS SECTION  
 Insulated Glass

**Door Size**  
 Daylight Opening

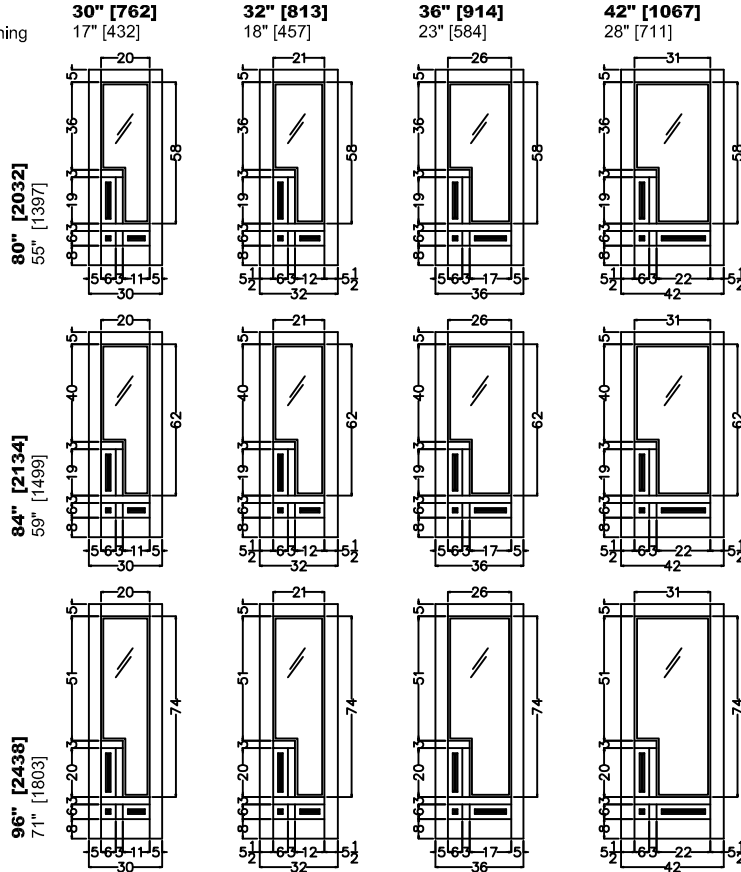

**Sidelight Size**  
 Daylight Opening

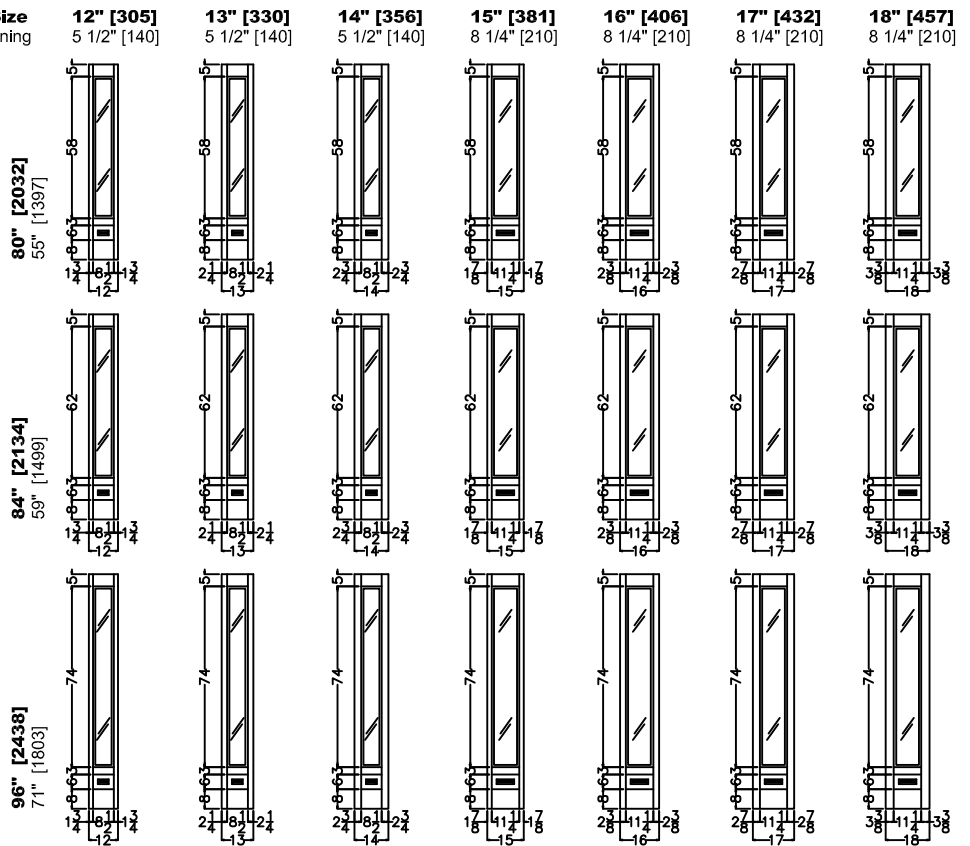

### ELEVATION NOTES

Door Size = Book Size Before Prefit  
 Daylight Opening (DLO) = Visible Glass  
 Values in brackets [ ] are millimeter conversions.

### DOOR CROSS-SECTION

Moulding Profile = 112  
 Panel Profile = Double Hip  
 See 201 Cross Section sheet for more detail.

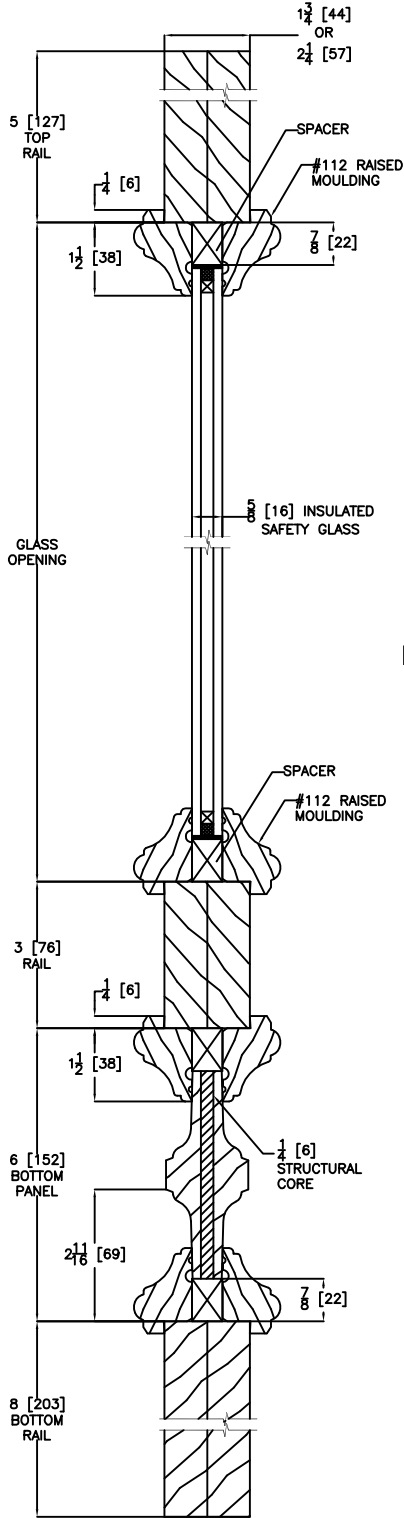

VERTICAL DOOR/SIDELIGHT CROSS SECTION  
 Insulated Glass

### HALF SEGMENT DOOR

Door Size  
 Daylight Opening

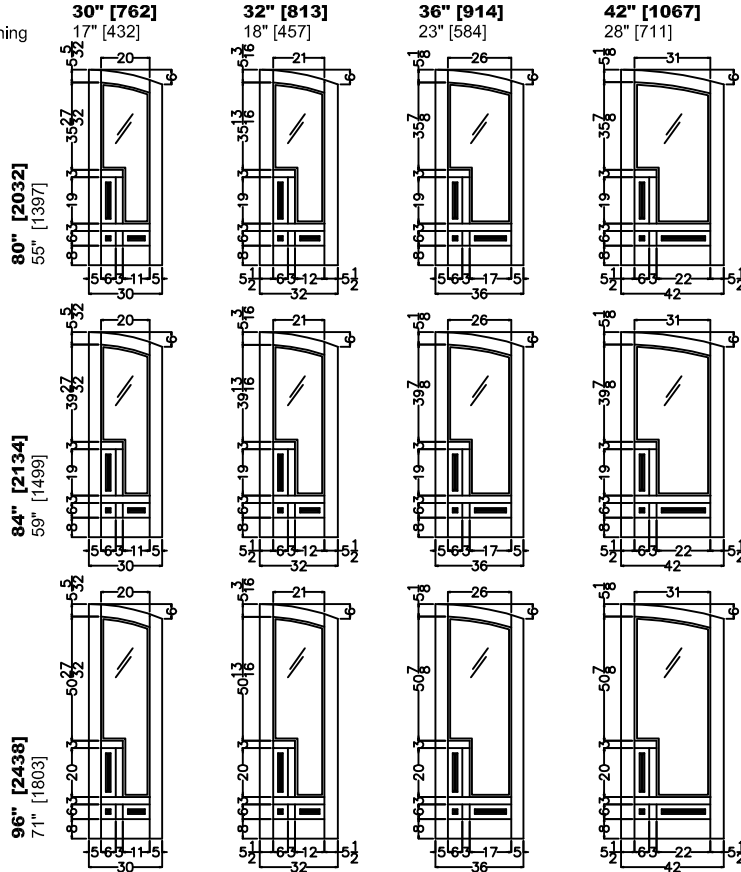

### FLAT SIDELIGHT

Sidelight Size  
 Daylight Opening

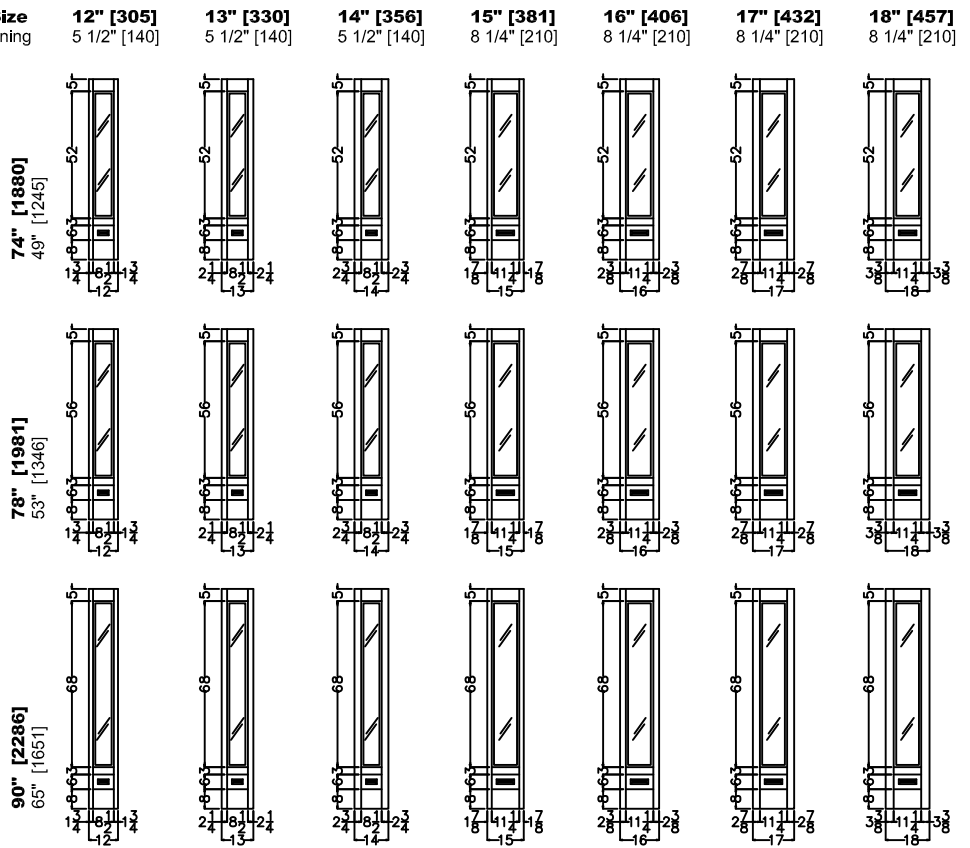

### ELEVATION NOTES

Door Size = Book Size Before Prefit  
 Daylight Opening (DLO) = Visible Glass  
 Values in brackets [ ] are millimeter conversions.

### DOOR CROSS-SECTION

Moulding Profile = 112  
 Panel Profile = Double Hip  
 See 202 Cross Section sheet for more detail.

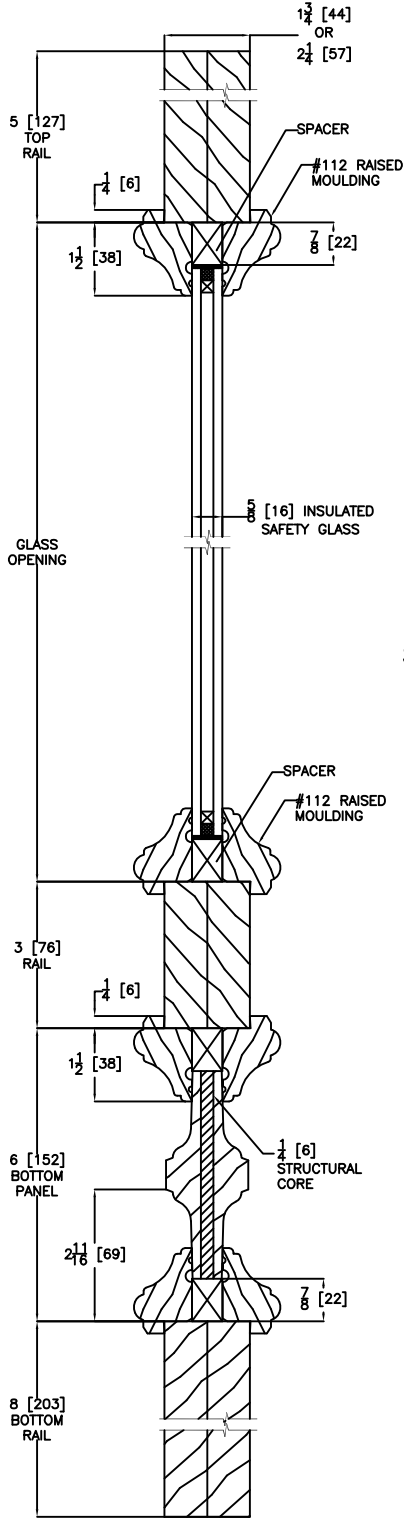

VERTICAL DOOR/SIDELIGHT CROSS SECTION  
 Insulated Glass

### HALF SEGMENT DOOR

**Door Size** 30" [762]  
**Daylight Opening** 17" [432]

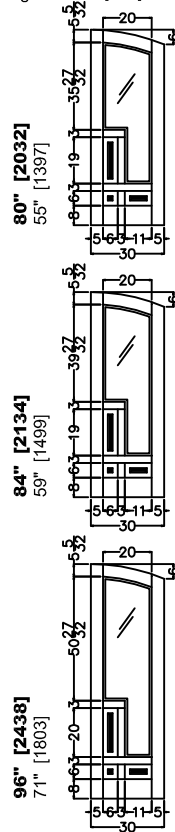

### SIDELIGHT TO MATCH 2-6

Sidelight Size	12" [305]	13" [330]	14" [356]	15" [381]	16" [406]	17" [432]	18" [457]
Daylight Opening	5 1/2" [140]	5 1/2" [140]	5 1/2" [140]	8 1/4" [210]	8 1/4" [210]	8 1/4" [210]	8 1/4" [210]

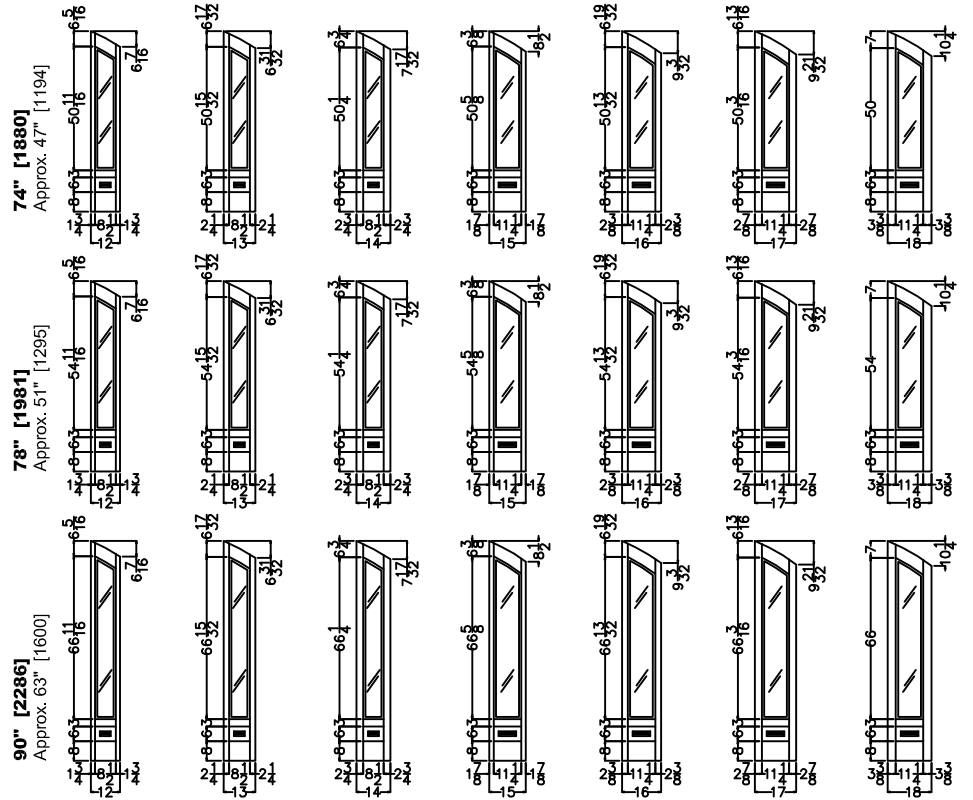

### ELEVATION NOTES

Door Size = Book Size Before Prefit  
 Daylight Opening (DLO) = Visible Glass  
 Values in brackets [ ] are millimeter conversions.

### DOOR CROSS-SECTION

Moulding Profile = 112  
 Panel Profile = Double Hip  
 See 202 Cross Section sheet for more detail.

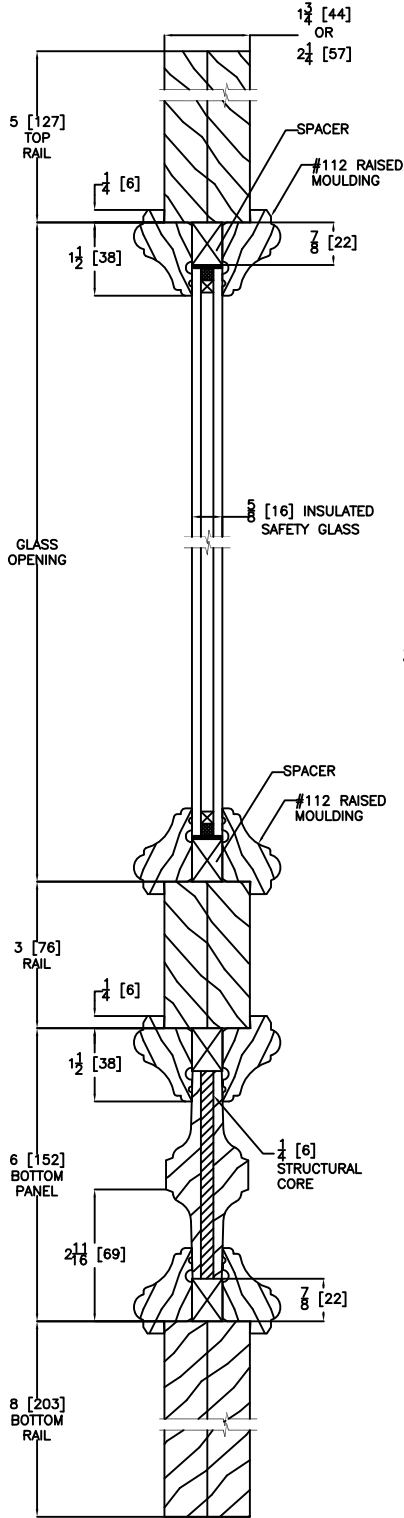

VERTICAL DOOR/SIDELIGHT CROSS SECTION  
 Insulated Glass

### HALF SEGMENT DOOR

**Door Size** 32" [813]  
**Daylight Opening** 18" [457]

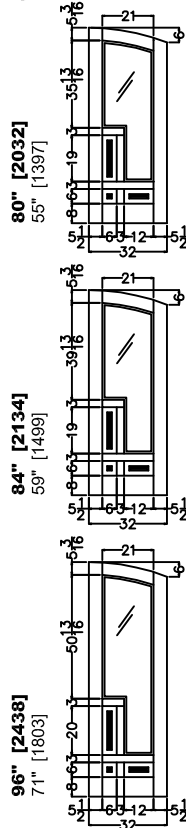

### SIDELIGHT TO MATCH 2-8

Sidelight Size	12" [305]	13" [330]	14" [356]	15" [381]	16" [406]	17" [432]	18" [457]
Daylight Opening	5 1/2" [140]	5 1/2" [140]	5 1/2" [140]	8 1/4" [210]	8 1/4" [210]	8 1/4" [210]	8 1/4" [210]

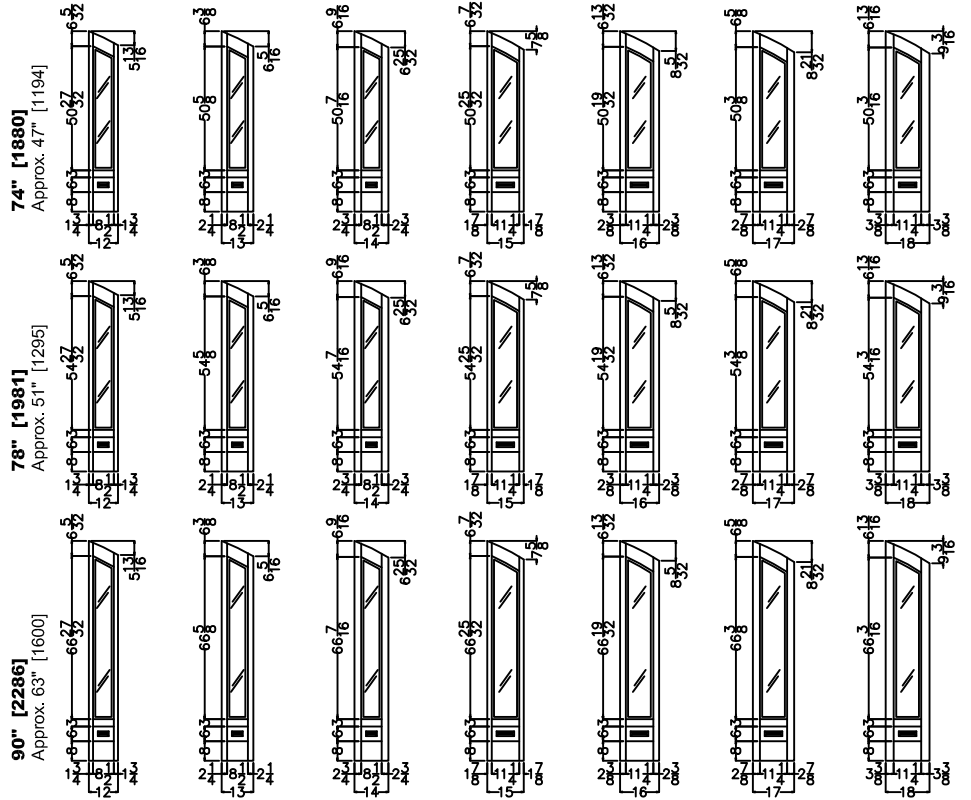

### ELEVATION NOTES

Door Size = Book Size Before Prefit  
 Daylight Opening (DLO) = Visible Glass  
 Values in brackets [ ] are millimeter conversions.

### DOOR CROSS-SECTION

Moulding Profile = 112  
 Panel Profile = Double Hip  
 See 202 Cross Section sheet for more detail.

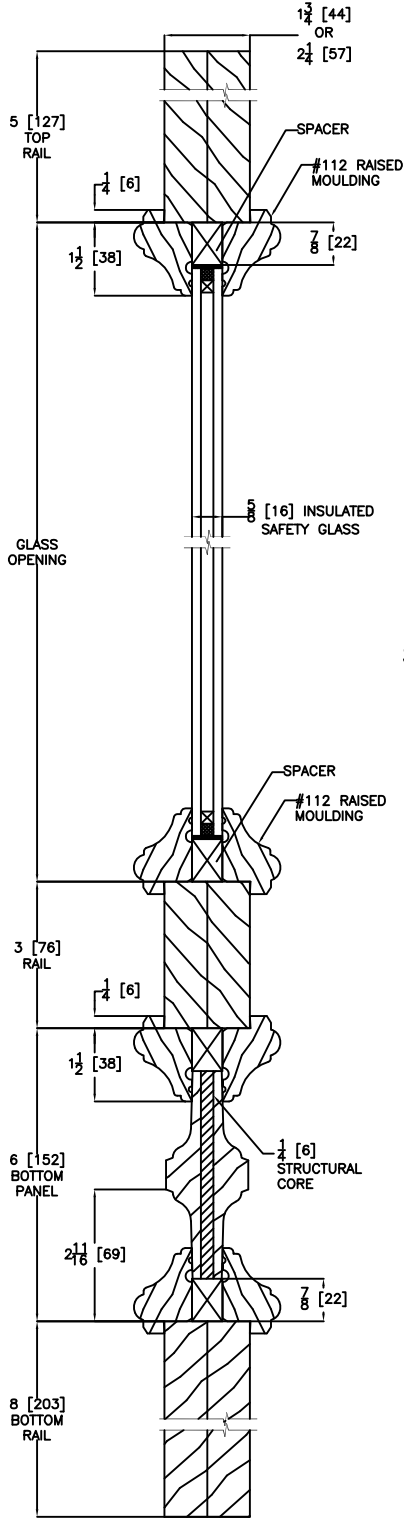

VERTICAL DOOR/SIDELIGHT CROSS SECTION  
 Insulated Glass

### HALF SEGMENT DOOR

**Door Size** 36" [914]  
**Daylight Opening** 23" [584]

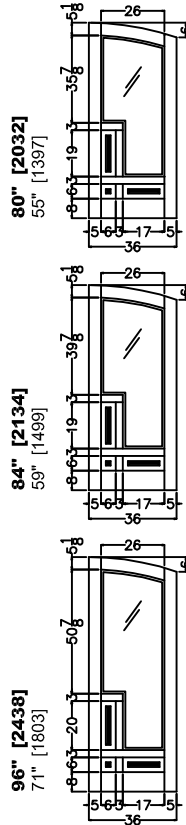

### SIDELIGHT TO MATCH 3-0

**Sidelight Size** 12" [305] 13" [330] 14" [356] 15" [381] 16" [406] 17" [432] 18" [457]  
**Daylight Opening** 5 1/2" [140] 5 1/2" [140] 5 1/2" [140] 8 1/4" [210] 8 1/4" [210] 8 1/4" [210] 8 1/4" [210]

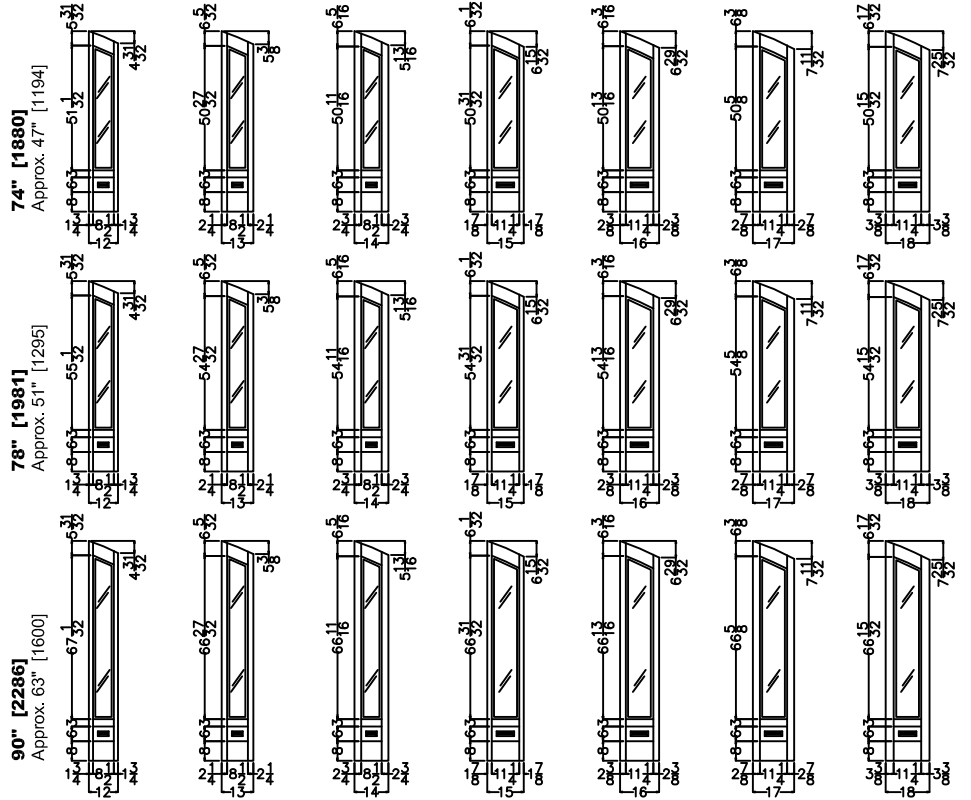

### ELEVATION NOTES

Door Size = Book Size Before Prefit  
 Daylight Opening (DLO) = Visible Glass  
 Values in brackets [ ] are millimeter conversions.

### DOOR CROSS-SECTION

Moulding Profile = 112  
 Panel Profile = Double Hip  
 See 202 Cross Section sheet for more detail.

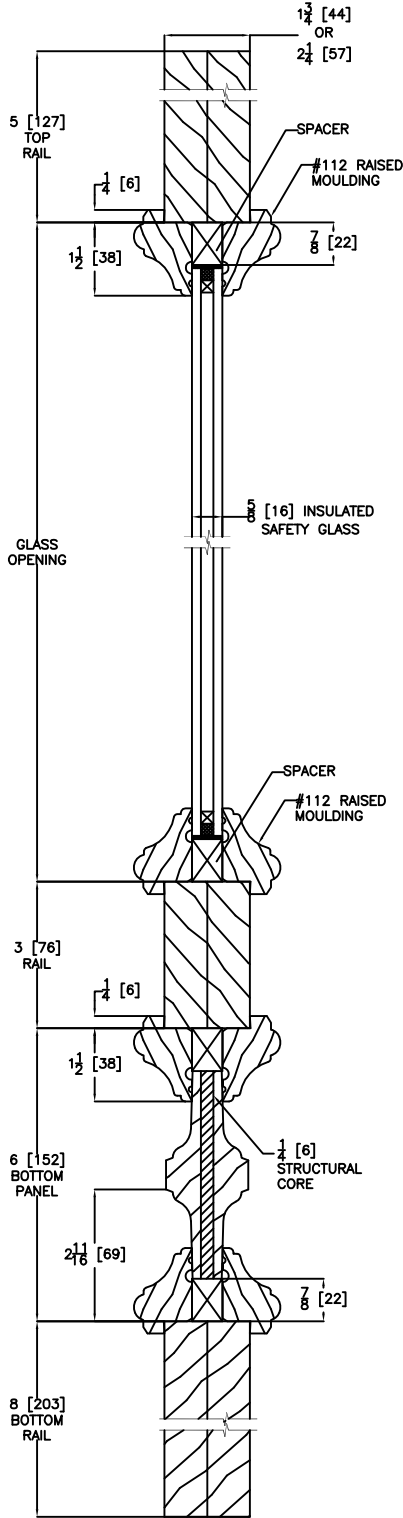

VERTICAL DOOR/SIDELIGHT CROSS SECTION  
 Insulated Glass

### HALF SEGMENT DOOR

Door Size 42" [1067]  
 Daylight Opening 28" [711]

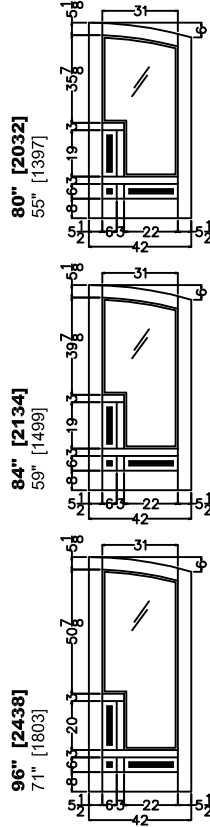

### SIDELIGHT TO MATCH 3-6

Sidelight Size	12" [305]	13" [330]	14" [356]	15" [381]	16" [406]	17" [432]	18" [457]
Daylight Opening	5 1/2" [140]	5 1/2" [140]	5 1/2" [140]	8 1/4" [210]	8 1/4" [210]	8 1/4" [210]	8 1/4" [210]

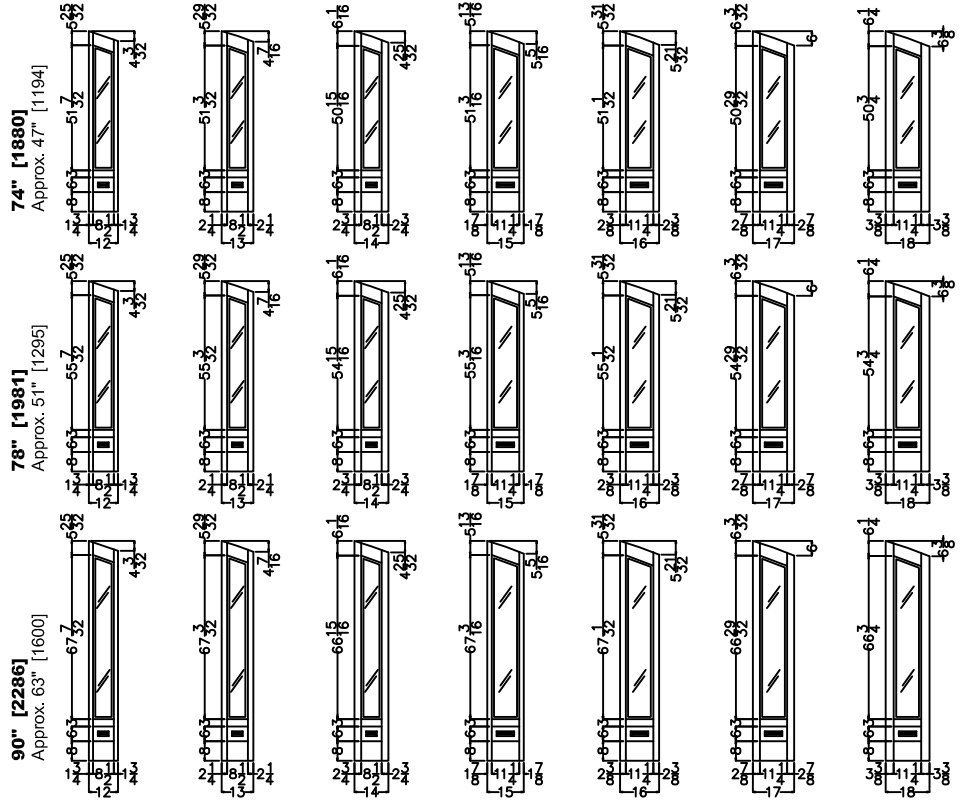



### ELEVATION NOTES

Door Size = Book Size Before Prefit  
 Daylight Opening (DLO) = Visible Glass  
 Values in brackets [ ] are millimeter conversions.

### DOOR CROSS-SECTION

Moulding Profile = 112  
 Panel Profile = Double Hip  
 See 203 Cross Section sheet for more detail.

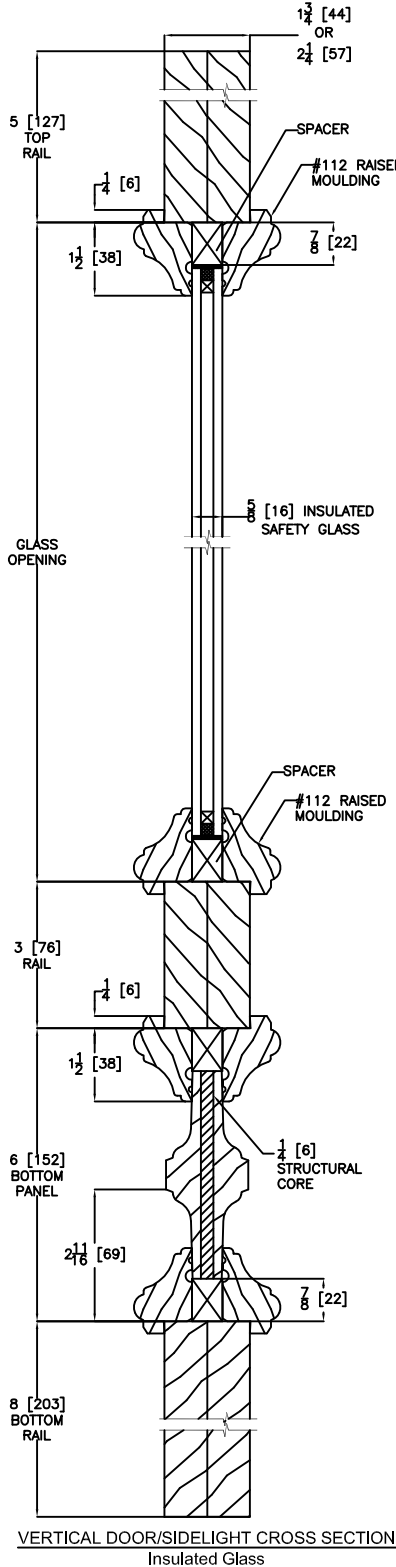

**Door Size**  
 Daylight Opening

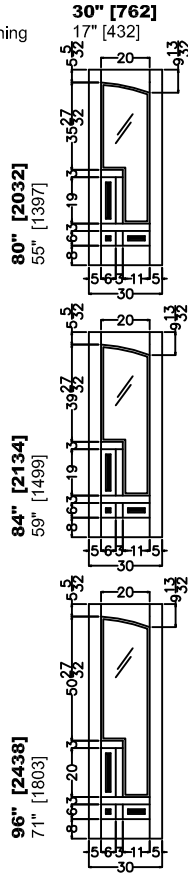

### SIDELIGHT TO MATCH 2-6

Sidelight Size	12" [305]	13" [330]	14" [356]	15" [381]	16" [406]	17" [432]	18" [457]
Daylight Opening	5 1/2" [140]	5 1/2" [140]	5 1/2" [140]	8 1/4" [210]	8 1/4" [210]	8 1/4" [210]	8 1/4" [210]

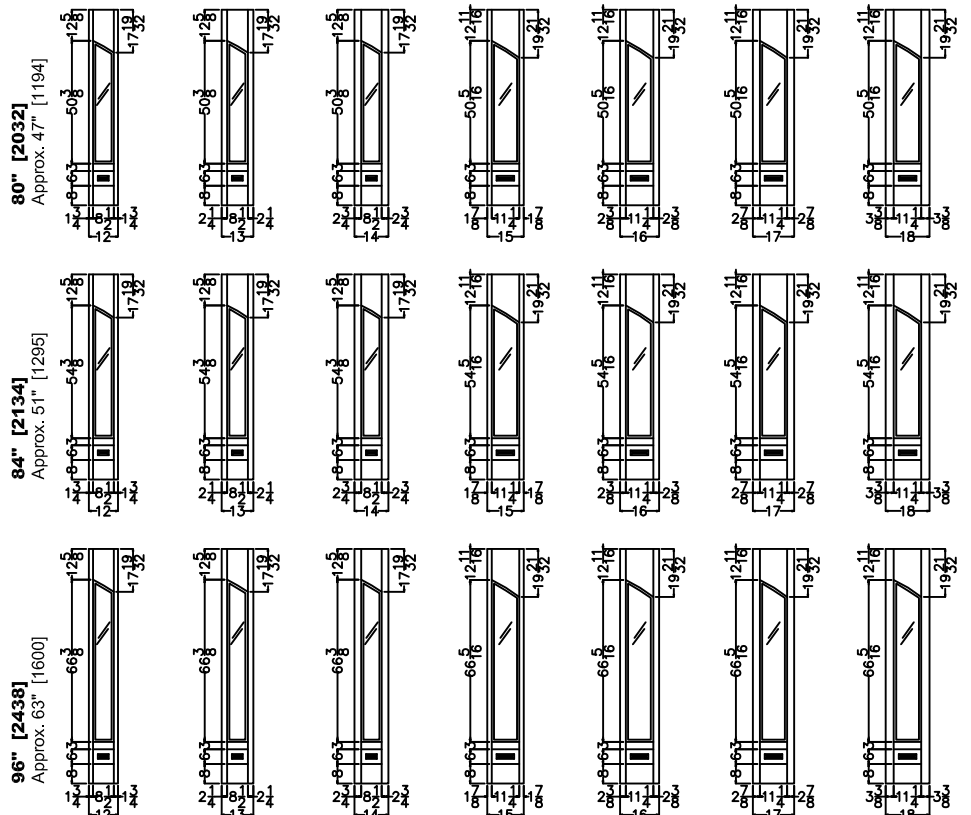

### ELEVATION NOTES

Door Size = Book Size Before Prefit  
 Daylight Opening (DLO) = Visible Glass  
 Values in brackets [ ] are millimeter conversions.

### DOOR CROSS-SECTION

Moulding Profile = 112  
 Panel Profile = Double Hip  
 See 203 Cross Section sheet for more detail.

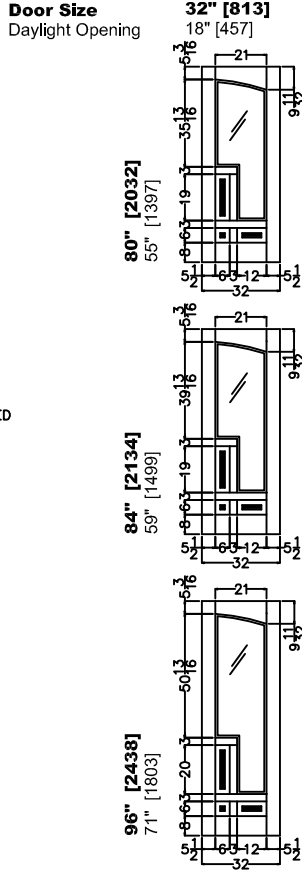
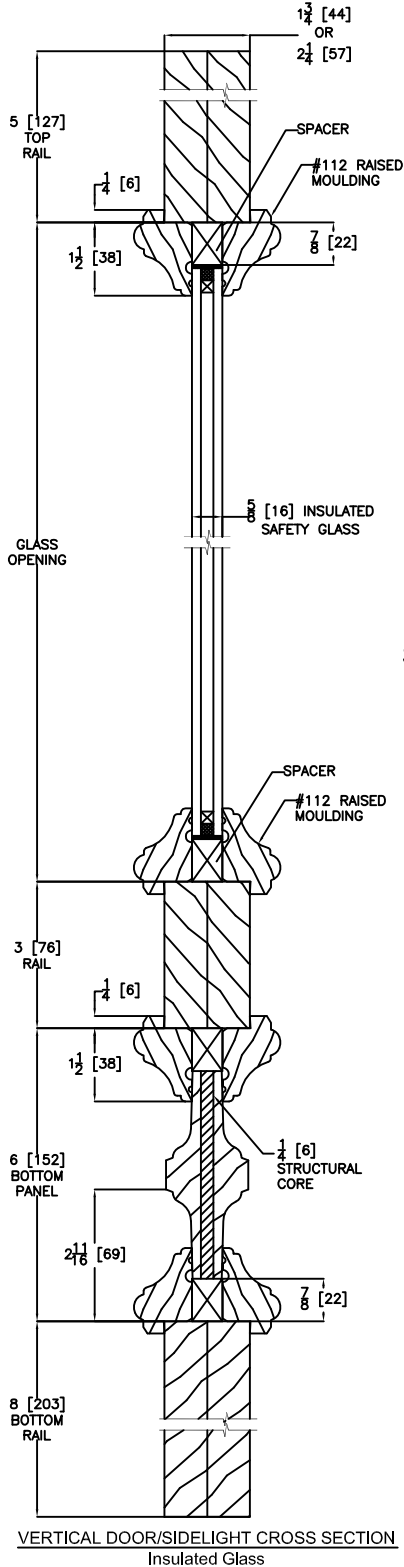

### SIDELIGHT TO MATCH 2-8

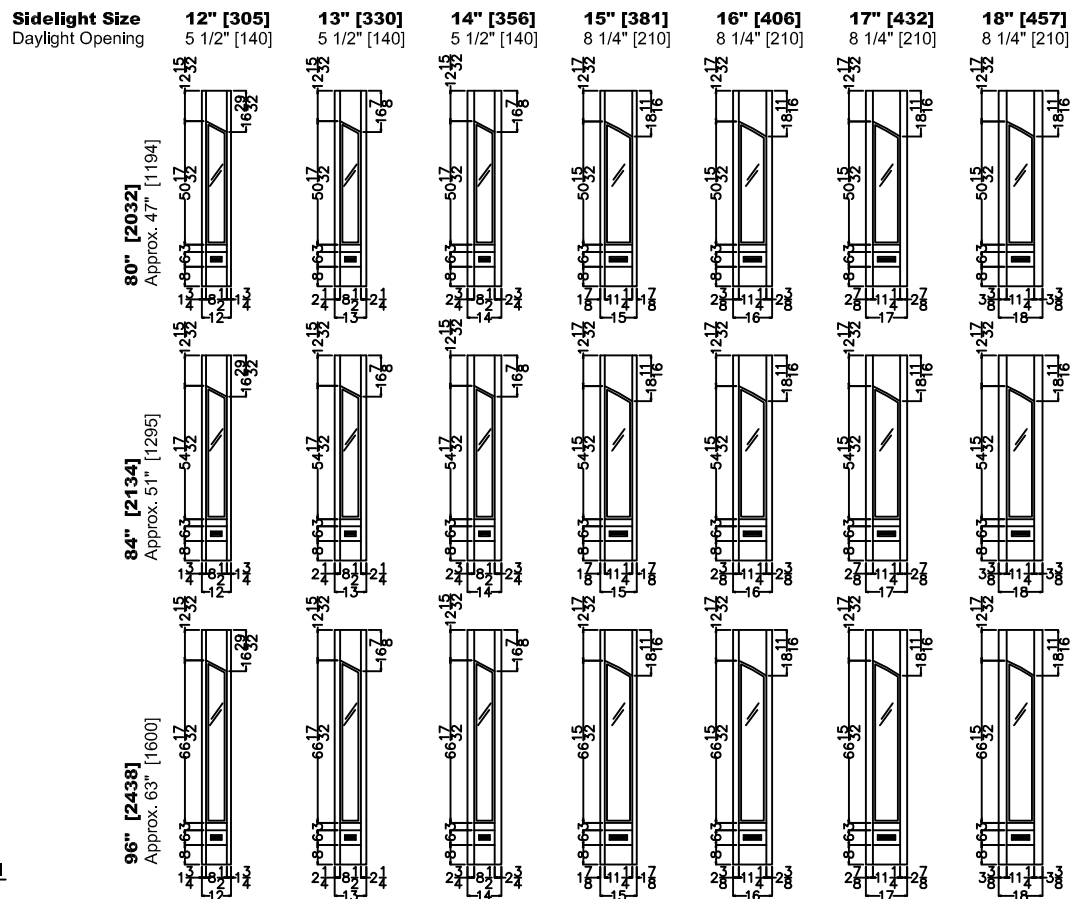

### ELEVATION NOTES

Door Size = Book Size Before Prefit  
 Daylight Opening (DLO) = Visible Glass  
 Values in brackets [ ] are millimeter conversions.

### DOOR CROSS-SECTION

Moulding Profile = 112  
 Panel Profile = Double Hip  
 See 203 Cross Section sheet for more detail.

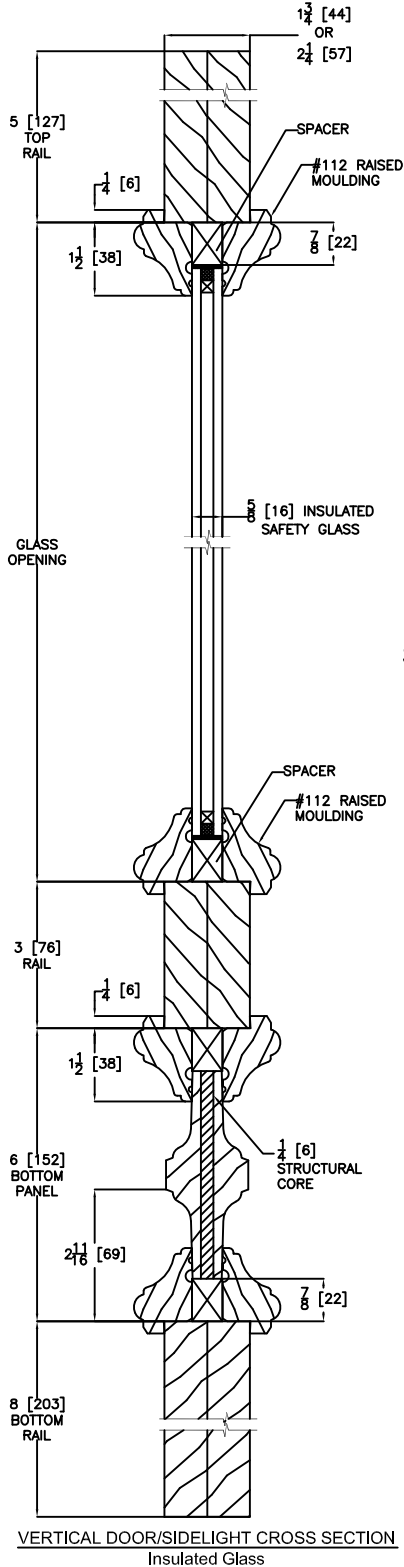

**Door Size**  
 Daylight Opening

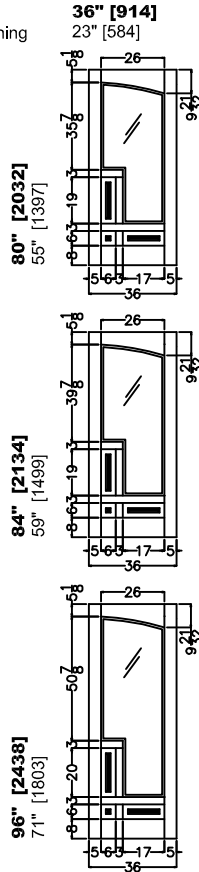

### SIDELIGHT TO MATCH 3-0

**Sidelight Size**  
 Daylight Opening

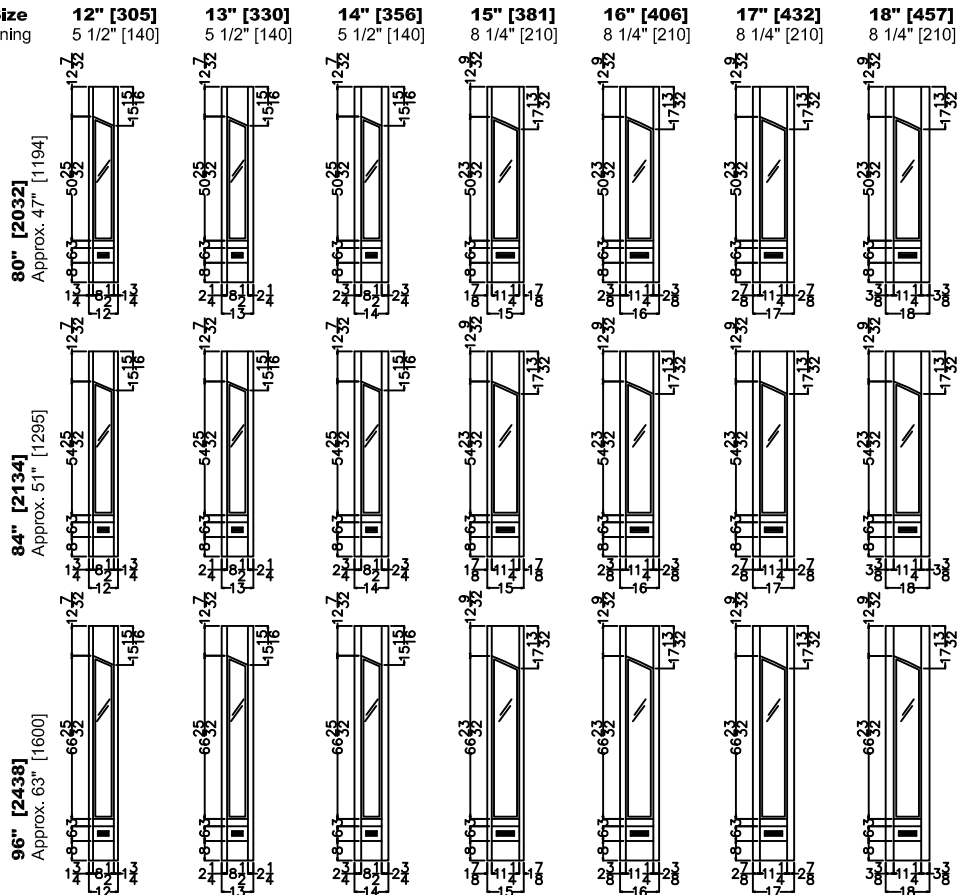

### ELEVATION NOTES

Door Size = Book Size Before Prefit  
 Daylight Opening (DLO) = Visible Glass  
 Values in brackets [ ] are millimeter conversions.

### DOOR CROSS-SECTION

Moulding Profile = 112  
 Panel Profile = Double Hip  
 See 203 Cross Section sheet for more detail.

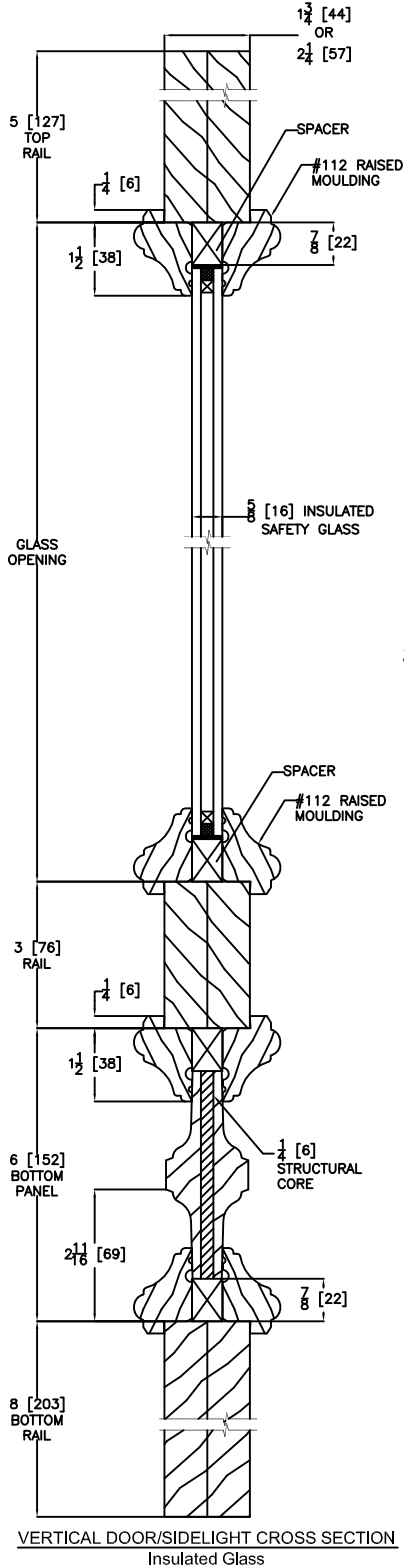

**Door Size**  
 Daylight Opening

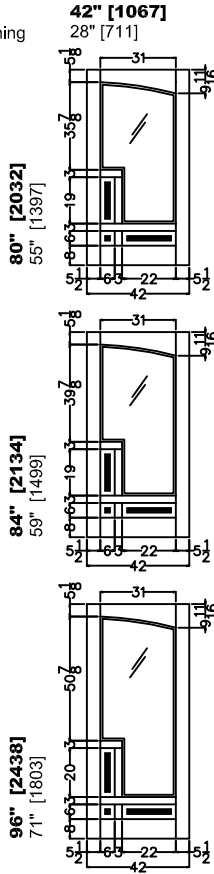

### SIDELIGHT TO MATCH 3-6

**Sidelight Size**  
 Daylight Opening

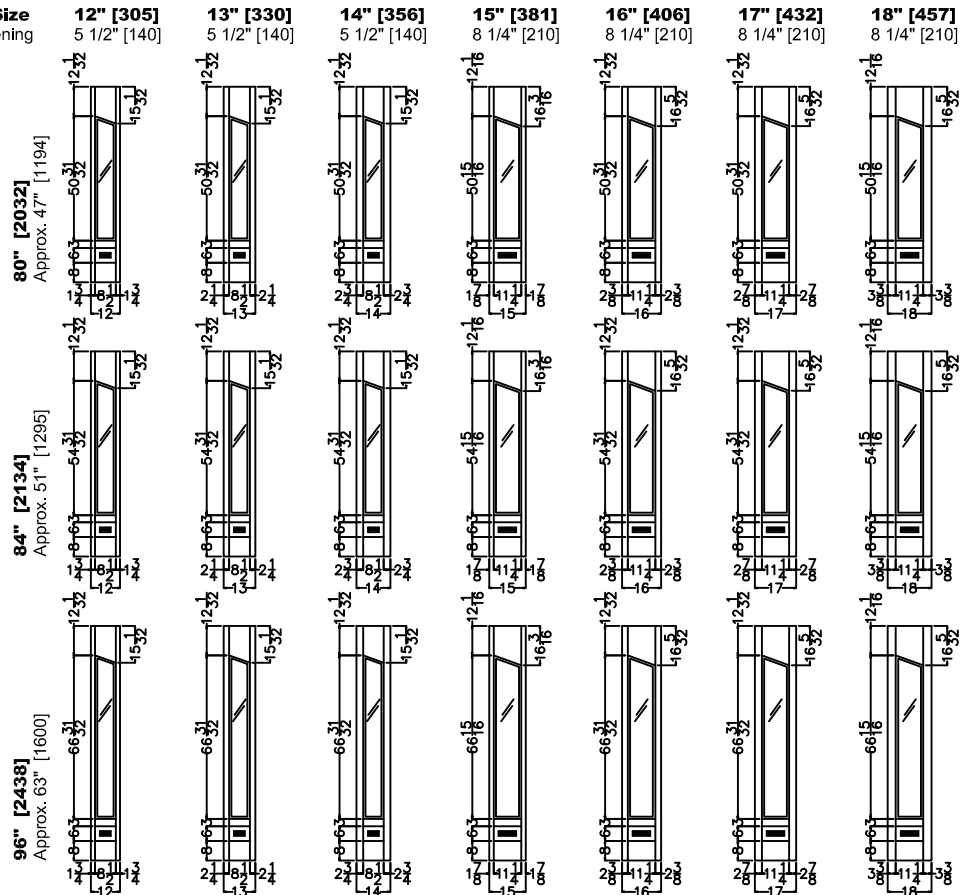

### ELEVATION NOTES

Door Size = Book Size Before Prefit  
 Daylight Opening (DLO) = Visible Glass  
 Values in brackets [ ] are millimeter conversions.

### DOOR CROSS-SECTION

Moulding Profile = 141  
 Panel Profile = 45 Degree  
 See 402 Cross Section sheet for more detail.

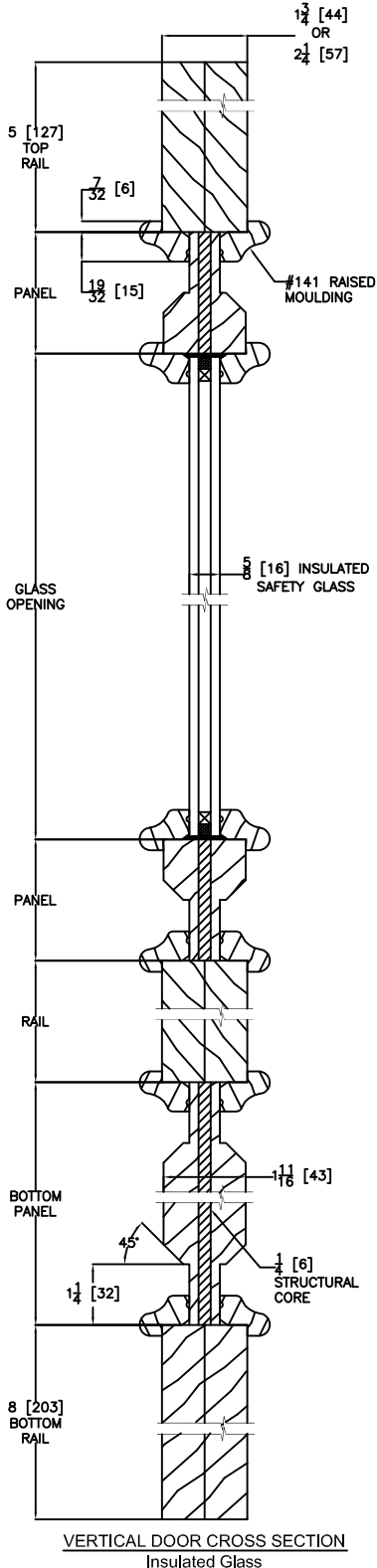

**Door Size**  
 Daylight Opening

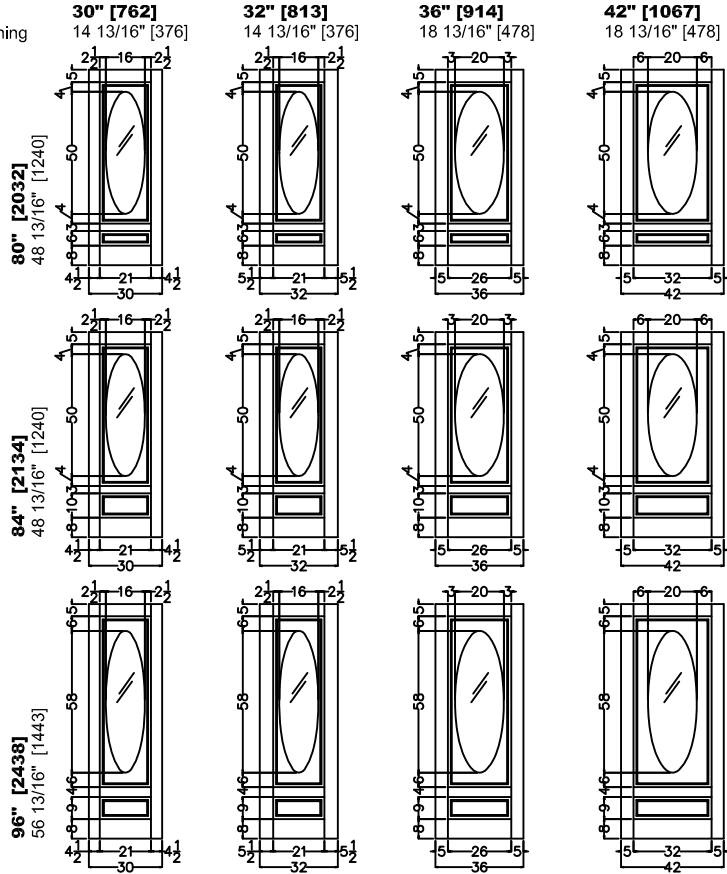

**Sidelight Size**  
 Daylight Opening

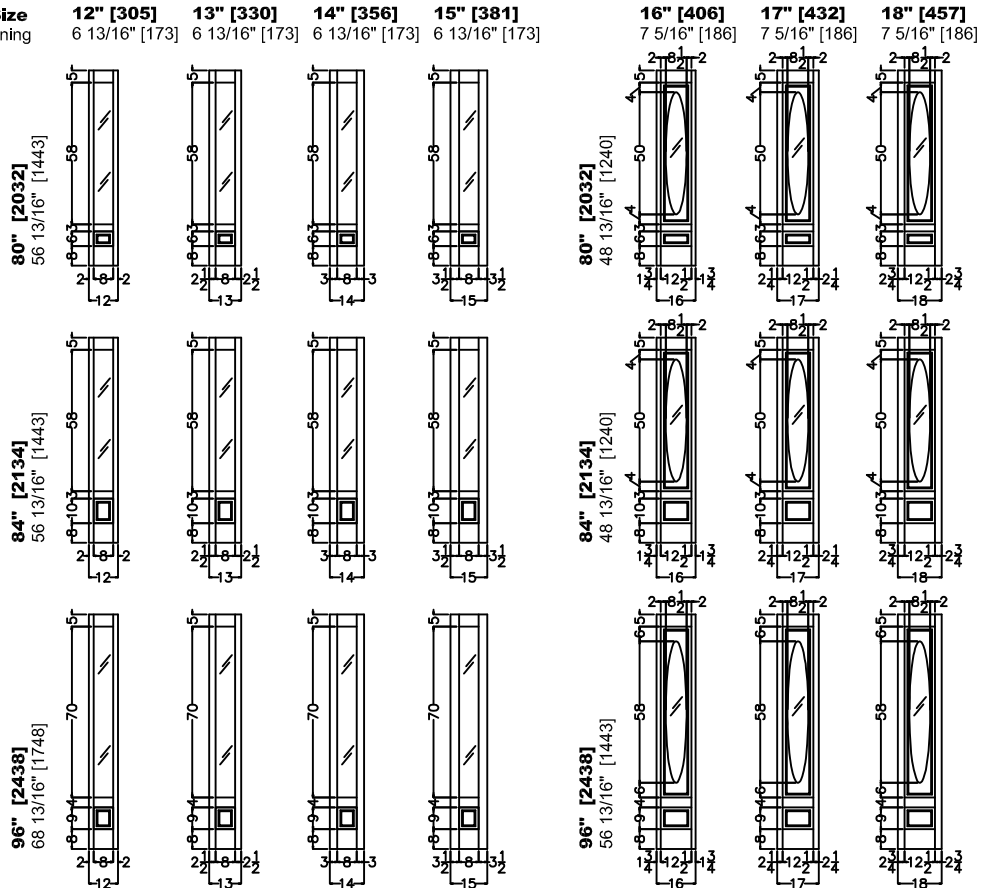

### ELEVATION NOTES

Door Size = Book Size Before Prefit  
 Daylight Opening (DLO) = Visible Glass  
 Values in brackets [ ] are millimeter conversions.

### DOOR CROSS-SECTION

Moulding Profile = 141 / Ovolo  
 Panel Profile = 45 Degree  
 See 408 Cross Section sheet for more detail.

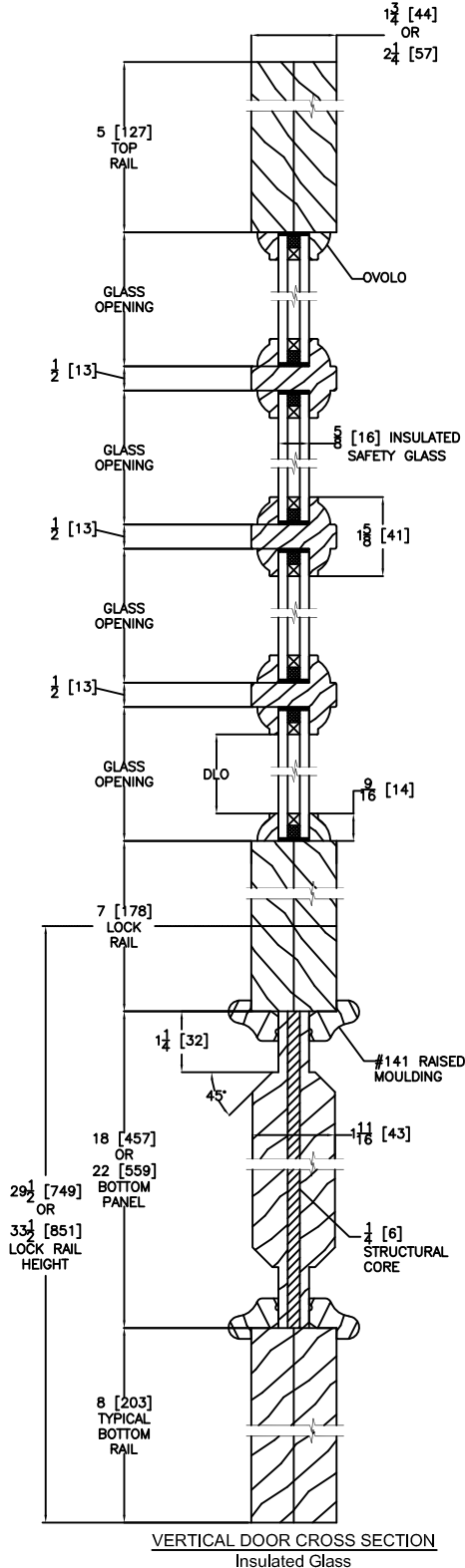

**Door Size**  
 Daylight Opening

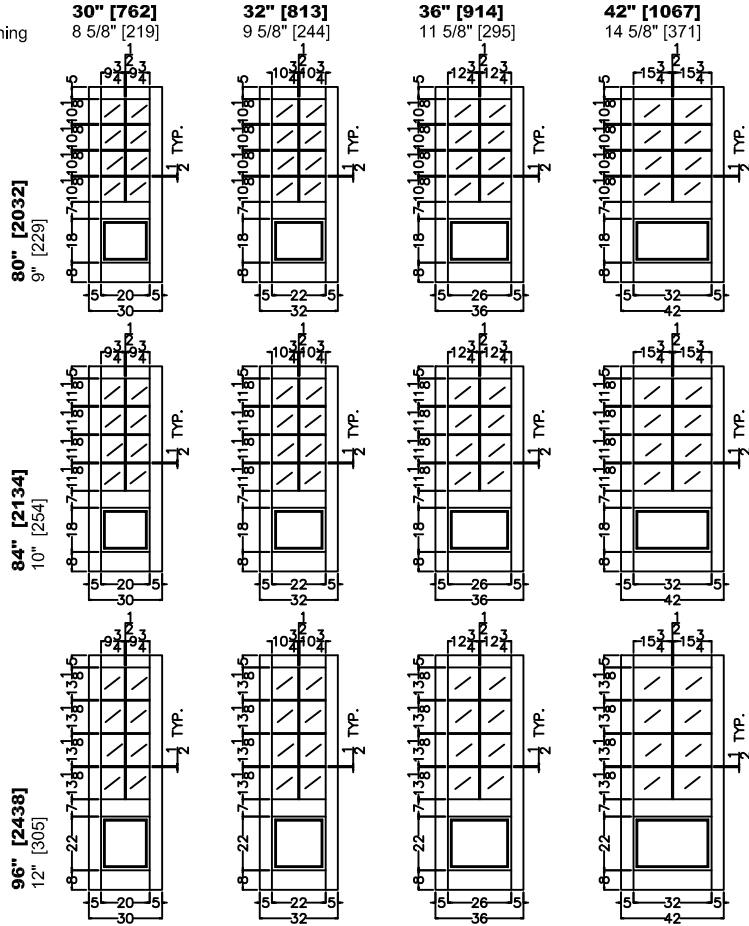

### ELEVATION NOTES

Door Size = Book Size Before Prefit  
 Daylight Opening (DLO) = Visible Glass  
 Values in brackets [ ] are millimeter conversions.

### DOOR CROSS-SECTION

Moulding Profile = 141 / Ovolo  
 Panel Profile = 45 Degree  
 See 408 Cross Section sheet for more detail.

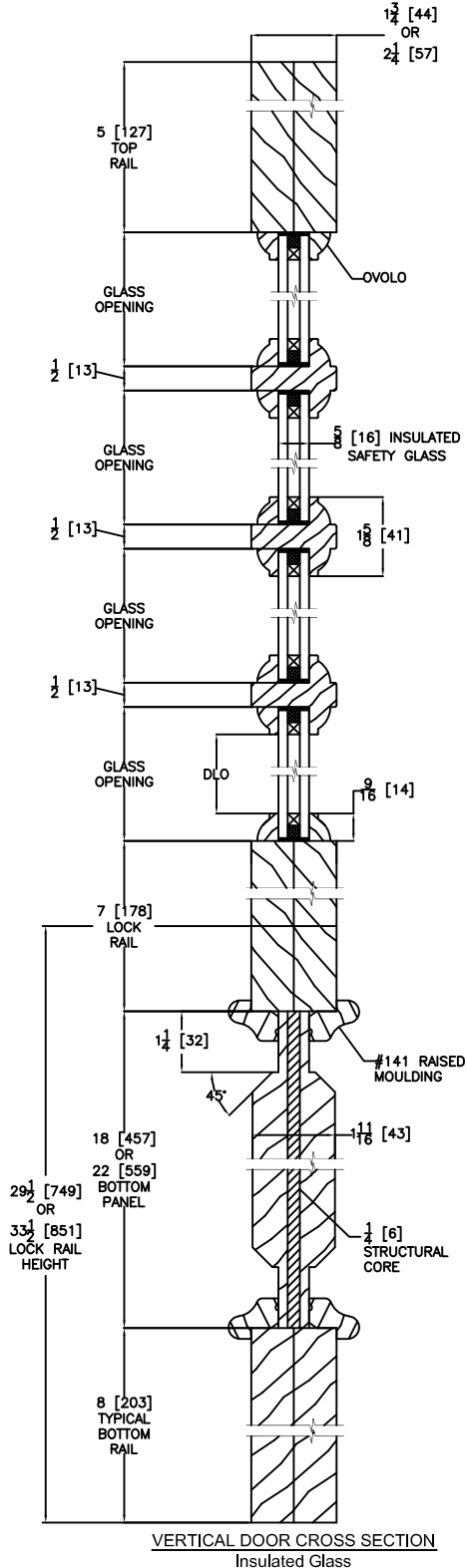

### RADIUS

**Door Size**  
 Daylight Opening

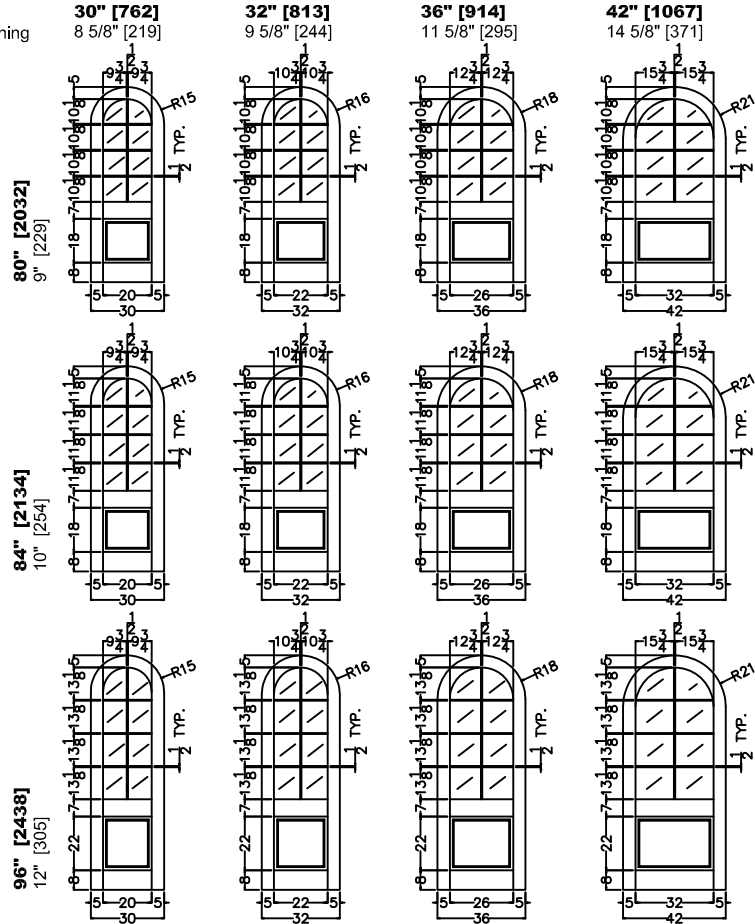

VERTICAL DOOR CROSS SECTION  
 Insulated Glass

### SEGMENT

**Door Size**  
Daylight Opening

### ELEVATION NOTES

Door Size = Book Size Before Prefit  
Daylight Opening (DLO) = Visible Glass  
Values in brackets [ ] are millimeter conversions.

### DOOR CROSS-SECTION

Moulding Profile = 141 / Ovolo  
Panel Profile = 45 Degree  
See 408 Cross Section sheet for more detail.

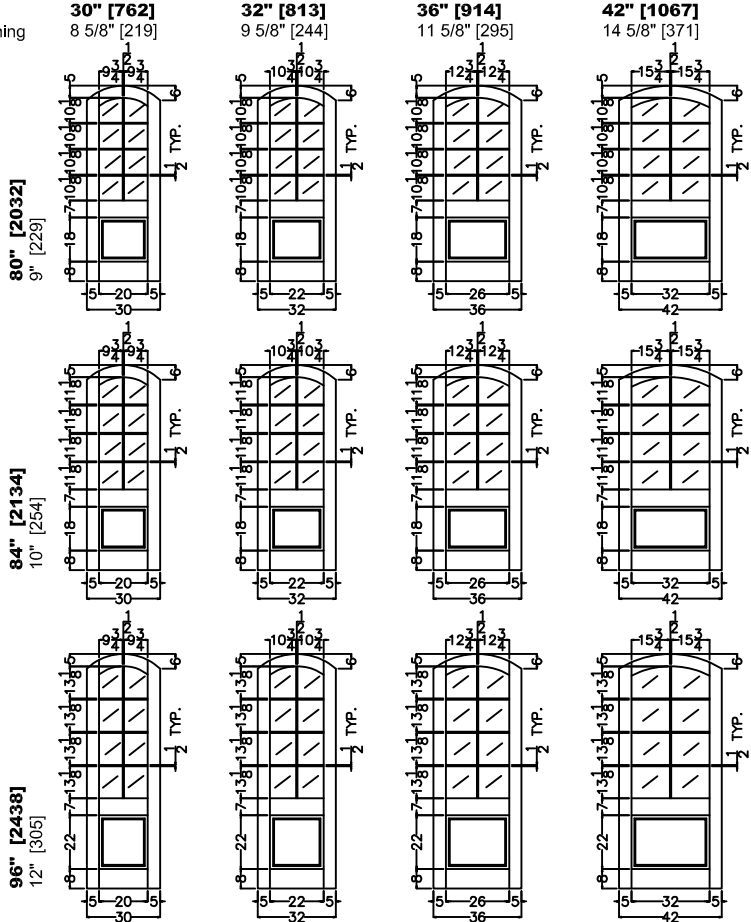
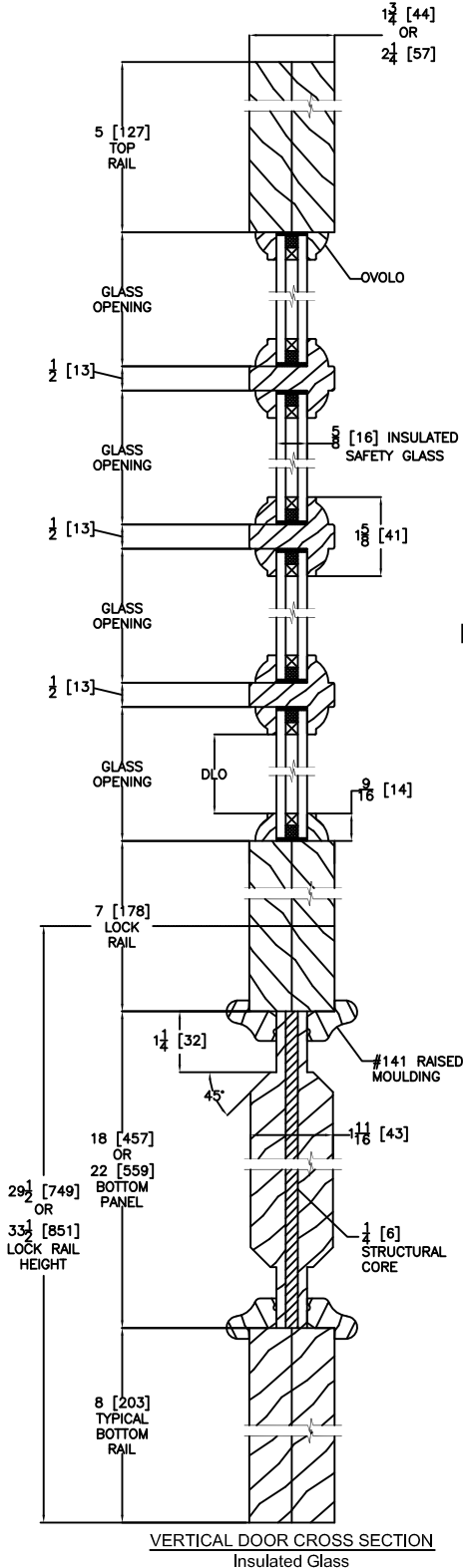

### HALF SEGMENT

**Door Size**  
Daylight Opening

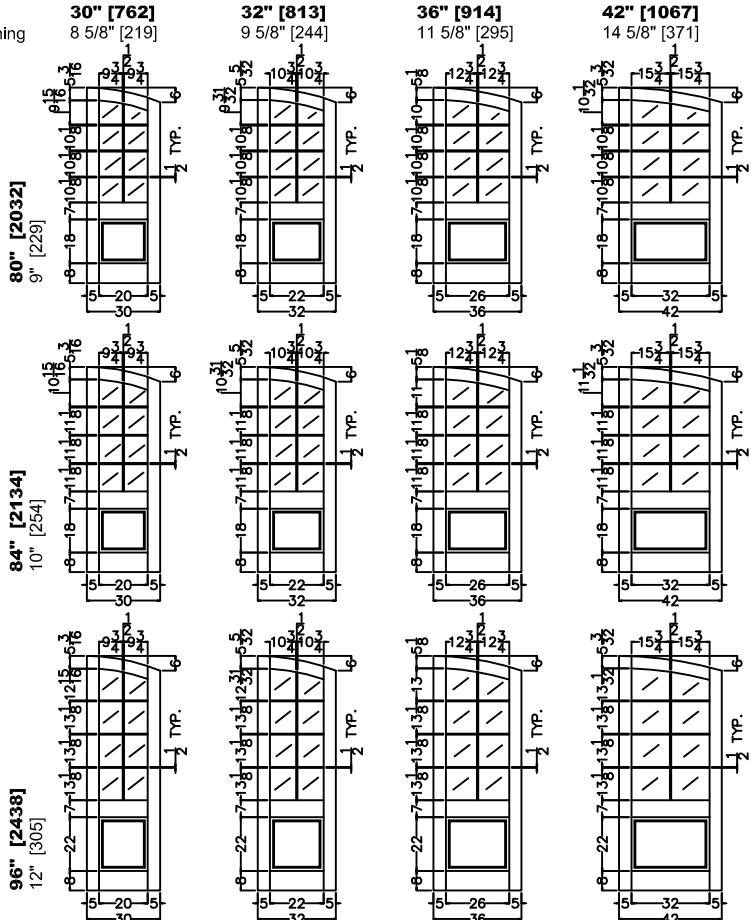



### ELEVATION NOTES

Door Size = Book Size Before Prefit  
 Daylight Opening (DLO) = Visible Glass  
 Values in brackets [ ] are millimeter conversions.

### DOOR CROSS-SECTION

Moulding Profile = 141  
 Panel Profile = 45 Degree  
 See 423 Cross Section sheet for more detail.

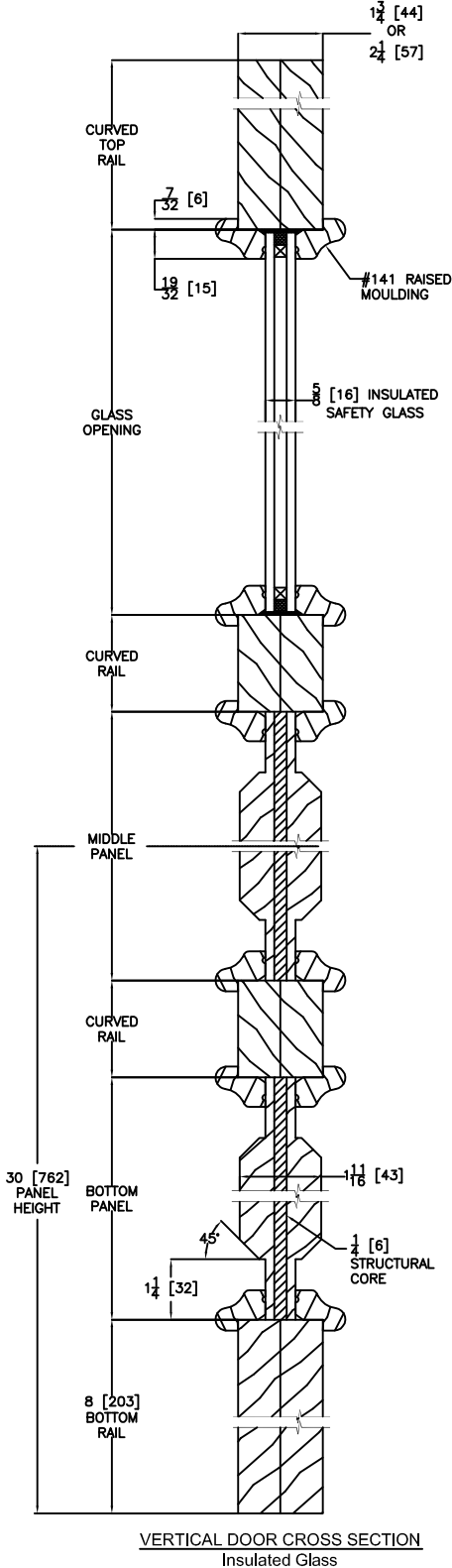

Door Size	30" [762]	32" [813]	36" [914]	42" [1067]
Daylight Opening	18 13/16" [478]	20 13/16" [529]	24 13/16" [630]	30 13/16" [783]
80" [2032] Various				
84" [2134] Various				
96" [2438] Various				

Sidelight Size	12" [305]	13" [330]	14" [356]	15" [381]	16" [406]	17" [432]	18" [457]
Daylight Opening	7 13/16" [198]	7 13/16" [198]	7 13/16" [198]	9 13/16" [249]	9 13/16" [249]	9 13/16" [249]	9 13/16" [249]
80" [2032] Various							
84" [2134] Various							
96" [2438] Various							

### ELEVATION NOTES

Door Size = Book Size Before Prefit  
 Daylight Opening (DLO) = Visible Glass  
 Values in brackets [ ] are millimeter conversions.

### DOOR CROSS-SECTION

Moulding Profile = Ovolo  
 Panel Profile = Double Hip  
 See 442 Cross Section sheet for more detail.

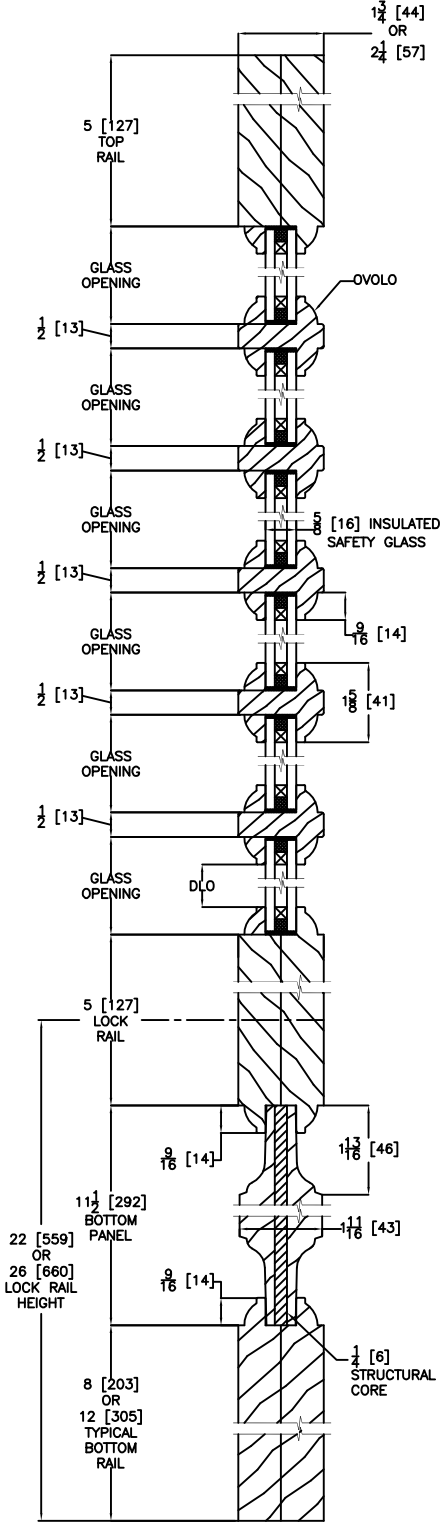

**Door Size**  
 Daylight Opening

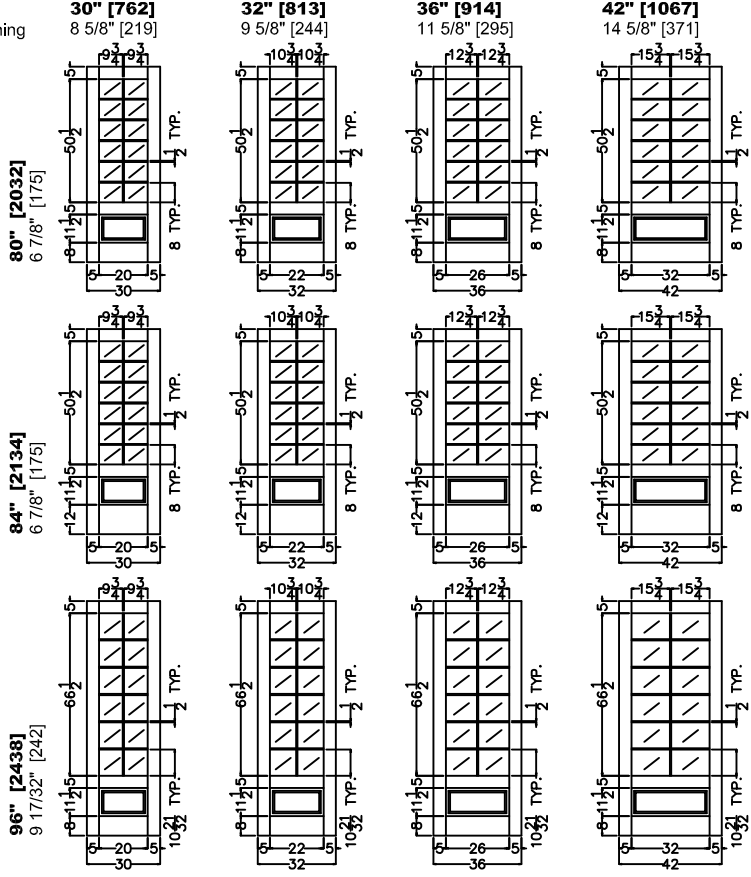

**Sidelight Size**  
 Daylight Opening

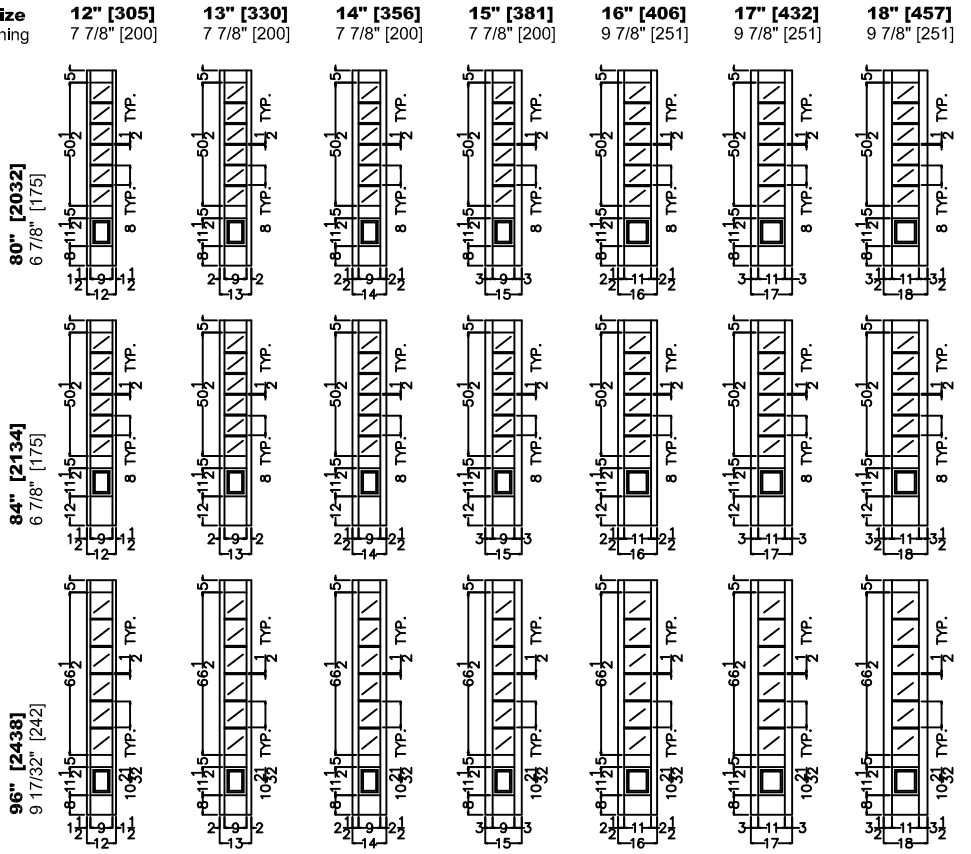

VERTICAL DOOR/SIDELIGHT CROSS SECTION  
 Insulated Glass

### ELEVATION NOTES

Door Size = Book Size Before Prefit  
 Daylight Opening (DLO) = Visible Glass  
 Values in brackets [ ] are millimeter conversions.

### DOOR CROSS-SECTION

Moulding Profile = 1200  
 Panel Profile = Convex Long  
 See 1260 Cross Section sheet for more detail.

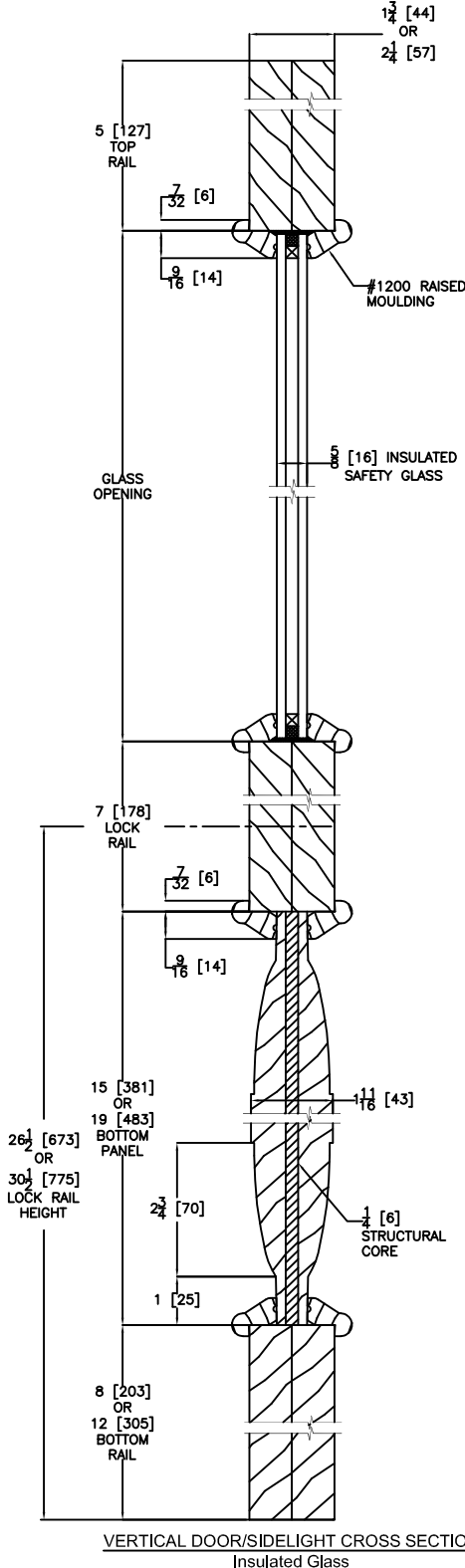

**Door Size**  
 Daylight Opening

**30" [762]**  
 18 7/8" [479]

**32" [813]**  
 20 7/8" [530]

**36" [914]**  
 24 7/8" [632]

**42" [1067]**  
 30 7/8" [784]

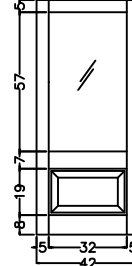
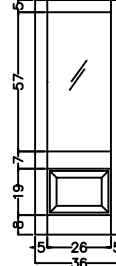
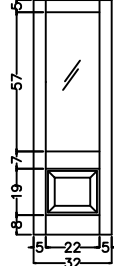
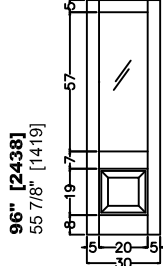
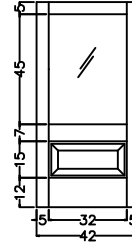
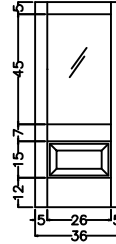
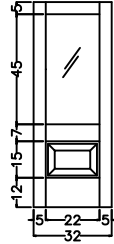
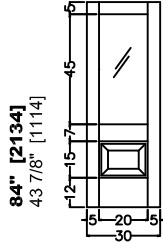
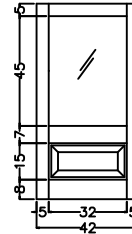
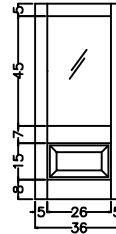
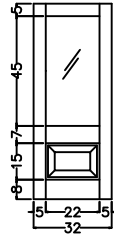
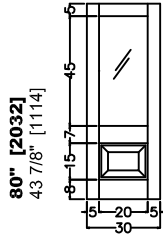

**Sidelight Size**  
 Daylight Opening

**12" [305]**  
 5 7/8" [149]

**13" [330]**  
 5 7/8" [149]

**14" [356]**  
 5 7/8" [149]

**15" [381]**  
 5 7/8" [149]

**16" [406]**  
 9 7/8" [251]

**17" [432]**  
 9 7/8" [251]

**18" [457]**  
 9 7/8" [251]

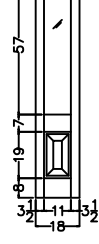
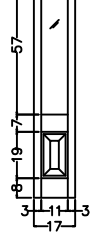
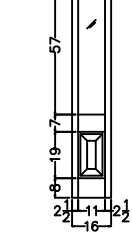
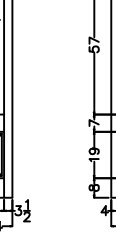
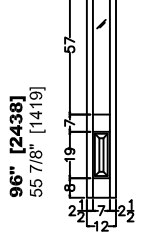
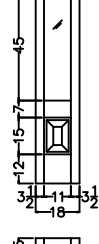
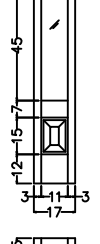
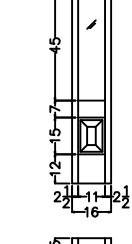
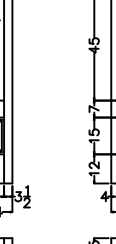
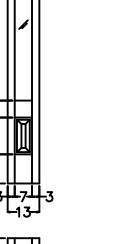
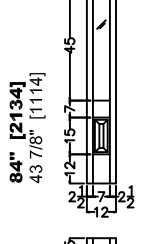
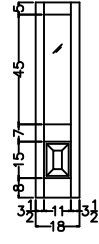
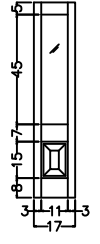
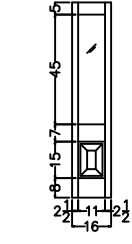
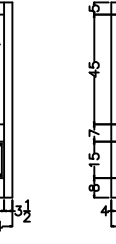
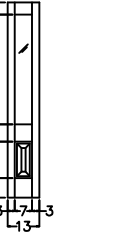
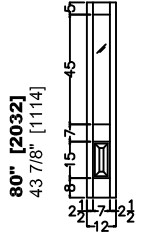

**STRAP  
 PLACEMENT  
 (Hardware  
 Optional)**

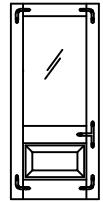

### ELEVATION NOTES

Door Size = Book Size Before Prefit  
 Daylight Opening (DLO) = Visible Glass  
 Values in brackets [ ] are millimeter conversions.

### DOOR CROSS-SECTION

Moulding Profile = 1200  
 Panel Profile = Convex Long  
 See 1260 Cross Section sheet for more detail.

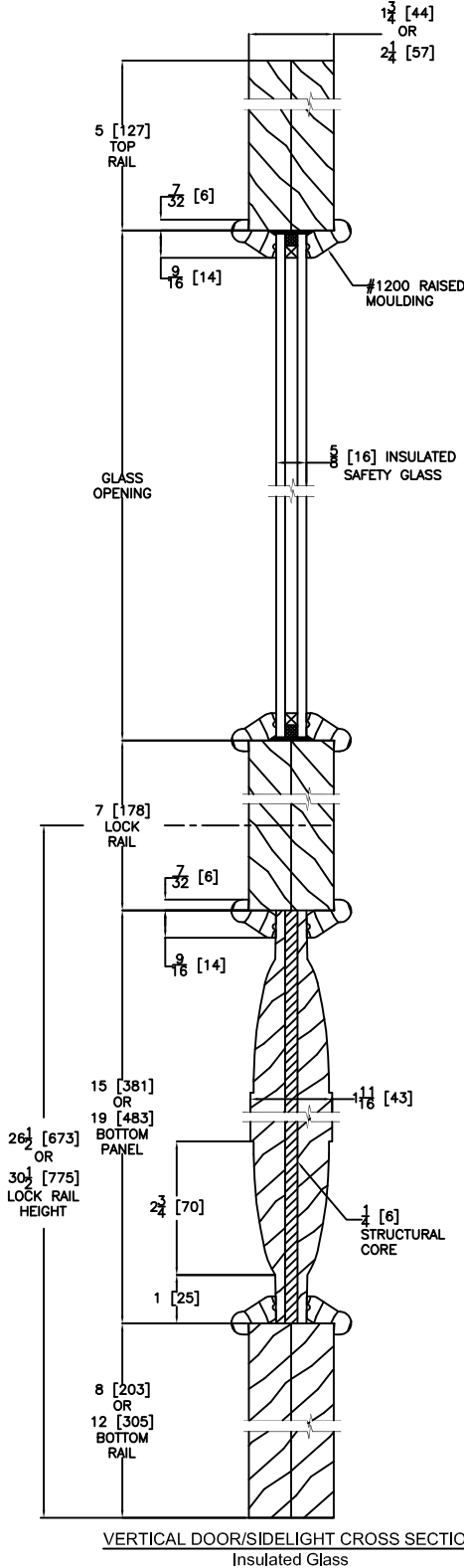

### Door Size

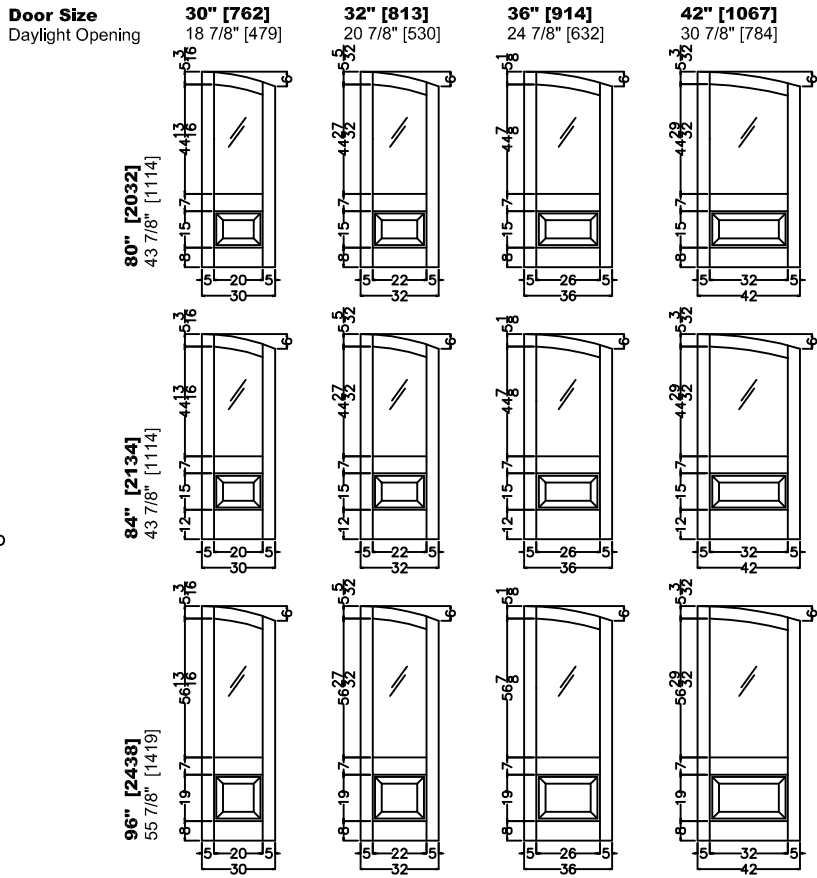

### STRAP PLACEMENT

(Hardware Optional/Custom Placement Available)

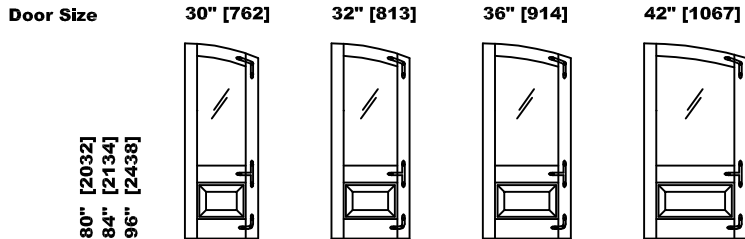

### ELEVATION NOTES

Door Size = Book Size Before Prefit  
 Daylight Opening (DLO) = Visible Glass  
 Values in brackets [ ] are millimeter conversions.

### DOOR CROSS-SECTION

Moulding Profile = 1200  
 Panel Profile = Convex Long  
 See 1260 Cross Section sheet for more detail.

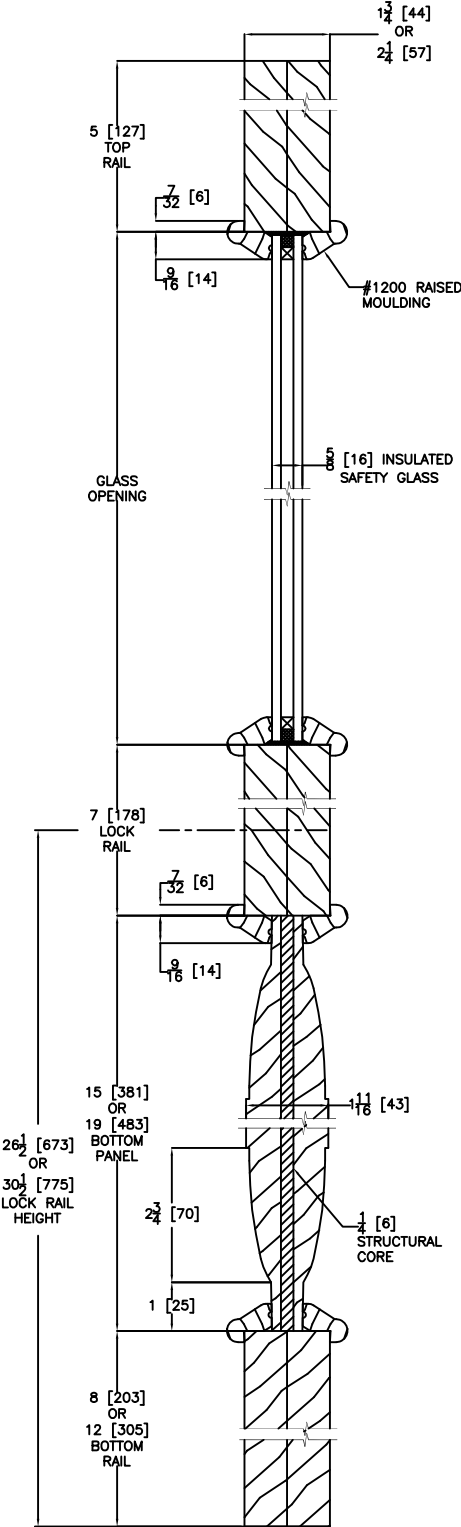

**Door Size**  
 Daylight Opening

**30" [762]**  
 18 7/8" [479]

**32" [813]**  
 20 7/8" [530]

**36" [914]**  
 24 7/8" [632]

**42" [1067]**  
 30 7/8" [784]

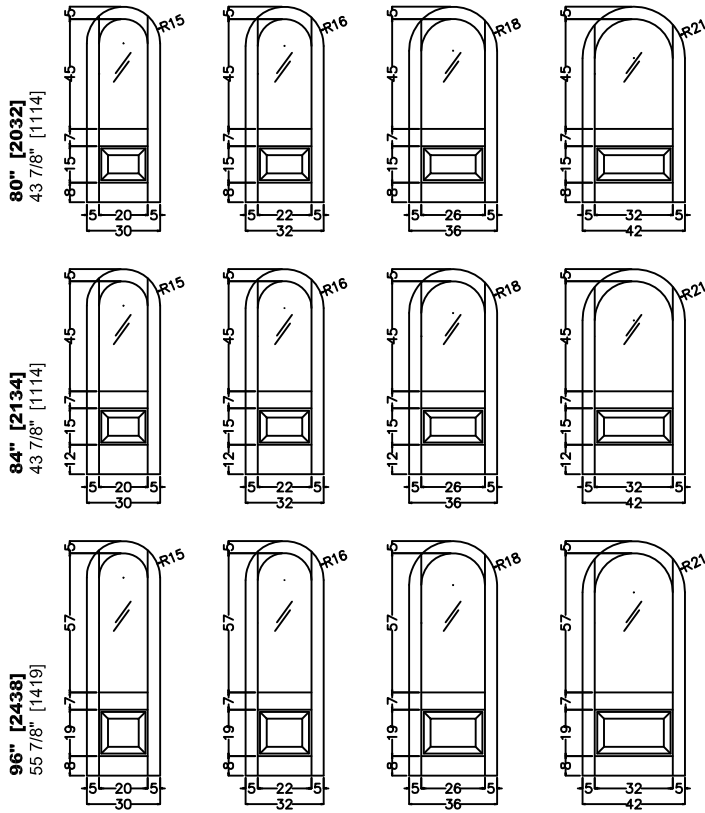

### STRAP PLACEMENT

(Hardware Optional/Custom Placement Available)

**Door Size**

**30" [762]**

**32" [813]**

**36" [914]**

**42" [1067]**

**80" [2032]**  
**84" [2134]**  
**96" [2438]**

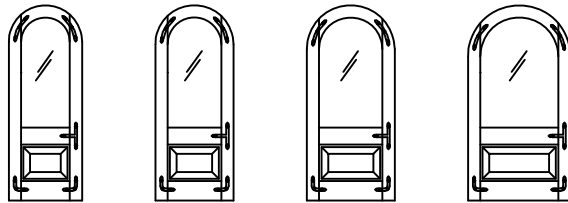

### ELEVATION NOTES

Door Size = Book Size Before Prefit  
 Daylight Opening (DLO) = Visible Glass  
 Values in brackets [ ] are millimeter conversions.

### DOOR CROSS-SECTION

Moulding Profile = 1200  
 Panel Profile = Convex Long  
 See 1260 Cross Section sheet for more detail.

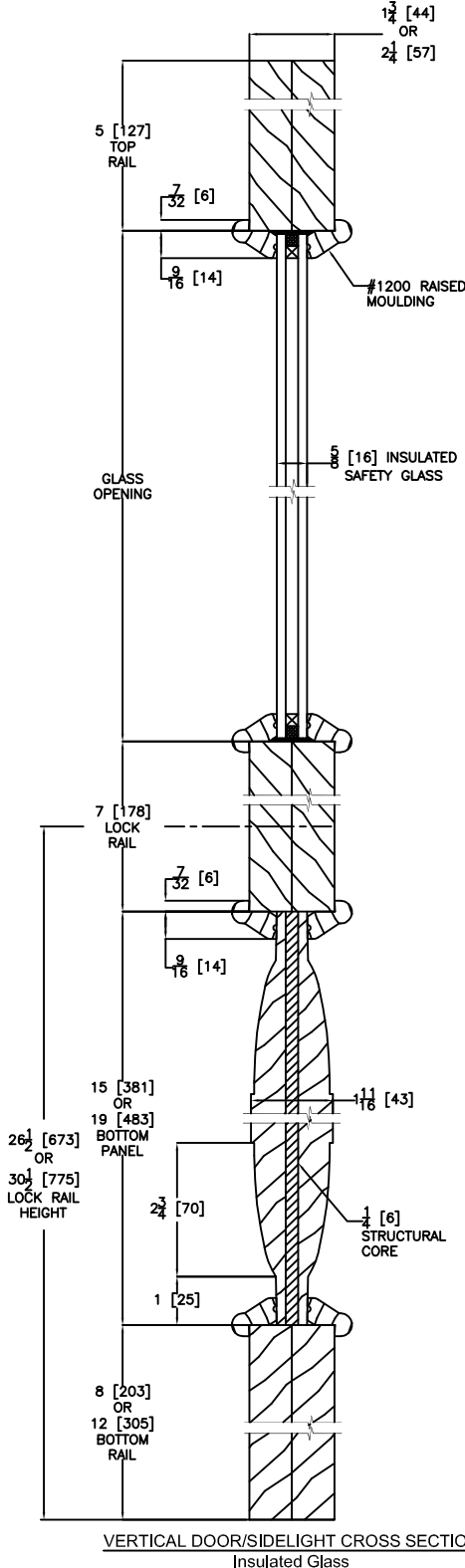

**Door Size**  
 Daylight Opening

**30" [762]**  
 18 7/8" [479]

**32" [813]**  
 20 7/8" [530]

**36" [914]**  
 24 7/8" [632]

**42" [1067]**  
 30 7/8" [784]

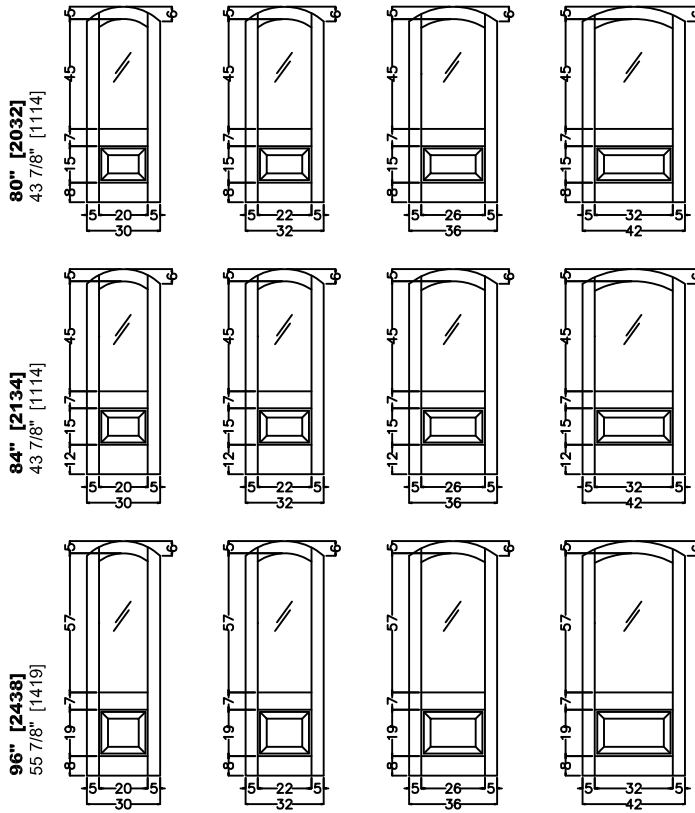

### STRAP PLACEMENT

(Hardware Optional/Custom Placement Available)

**Door Size**

**30" [762]**

**32" [813]**

**36" [914]**

**42" [1067]**

**80" [2032]**  
**84" [2134]**  
**96" [2438]**

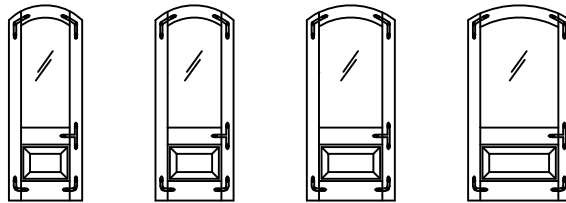

### ELEVATION NOTES

Door Size = Book Size Before Prefit  
 Daylight Opening (DLO) = Visible Glass  
 Values in brackets [ ] are millimeter conversions.

### DOOR CROSS-SECTION

Moulding Profile = 1200  
 Panel Profile = Convex Long  
 See 1265 Cross Section sheet for more detail.

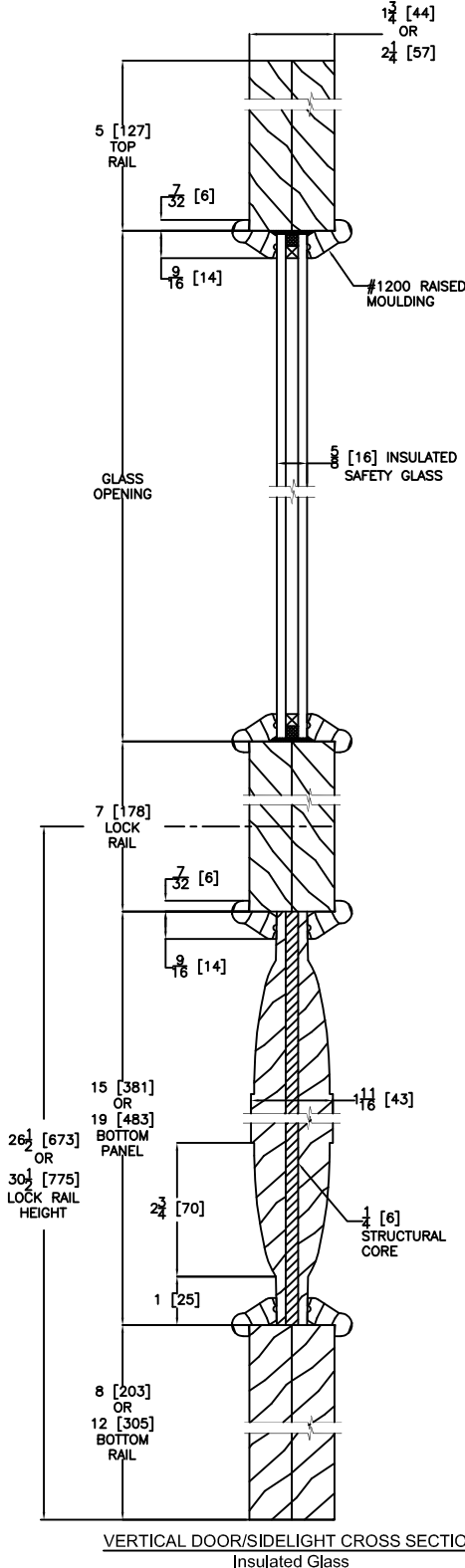

STRAP  
 PLACEMENT  
 (Hardware  
 Optional)

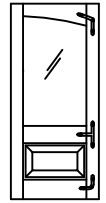

Door Size	30" [762]	32" [813]	36" [914]	42" [1067]	Sidelight Size	12" [305]	13" [330]	14" [356]	15" [381]	16" [406]	17" [432]	18" [457]
Daylight Opening	18 7/8" [479]	20 7/8" [530]	24 7/8" [632]	30 7/8" [784]	Daylight Opening	5 7/8" [149]	5 7/8" [149]	5 7/8" [149]	5 7/8" [149]	9 7/8" [251]	9 7/8" [251]	9 7/8" [251]
<b>80" [2032]</b> 43 7/8" [1114]					<b>80" [2032]</b> 43 7/8" [1114]							
<b>84" [2134]</b> 43 7/8" [1114]					<b>84" [2134]</b> 43 7/8" [1114]							
<b>96" [2438]</b> 55 7/8" [1419]					<b>96" [2438]</b> 55 7/8" [1419]							

### ELEVATION NOTES

Door Size = Book Size Before Prefit  
 Daylight Opening (DLO) = Visible Glass  
 Values in brackets [ ] are millimeter conversions.

### DOOR CROSS-SECTION

Moulding Profile = Shaker Stop  
 Panel Profile = V-Groove  
 See 1315 Cross Section sheet for more detail.

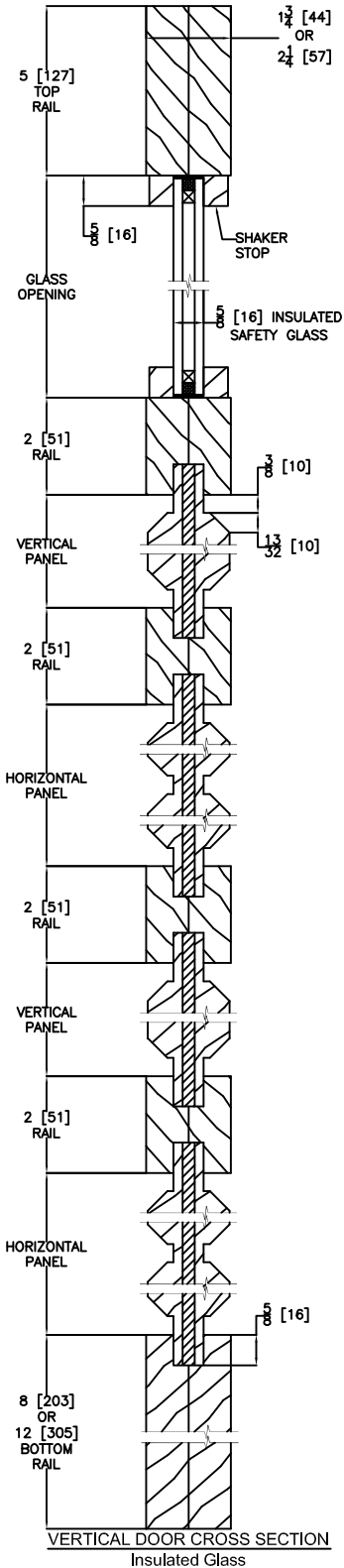

**Door Size**  
 Daylight Opening

**30" [762]**  
 4 3/4" [121]

**32" [813]**  
 4 3/4" [121]

**36" [914]**  
 6 3/32" [155]

**42" [1067]**  
 8 3/32" [206]

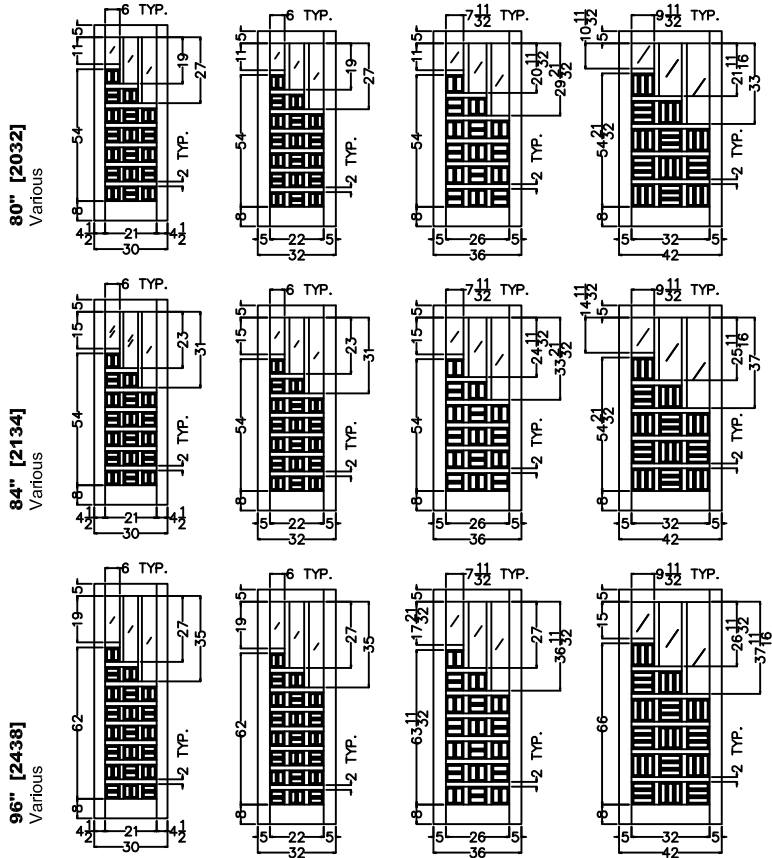

### DOOR LAYOUTS - DOUBLE DOOR

All Layouts Viewed from Exterior

**LAYOUT 1**

**LAYOUT 2**

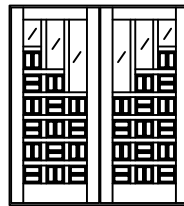
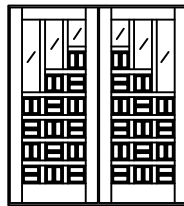



### ELEVATION NOTES

Door Size = Book Size Before Prefit  
 Daylight Opening (DLO) = Visible Glass  
 Values in brackets [ ] are millimeter conversions.

### DOOR CROSS-SECTION

Moulding Profile = Shaker Stop  
 Panel Profile = V-Groove  
 See 1315 Cross Section sheet for more detail.

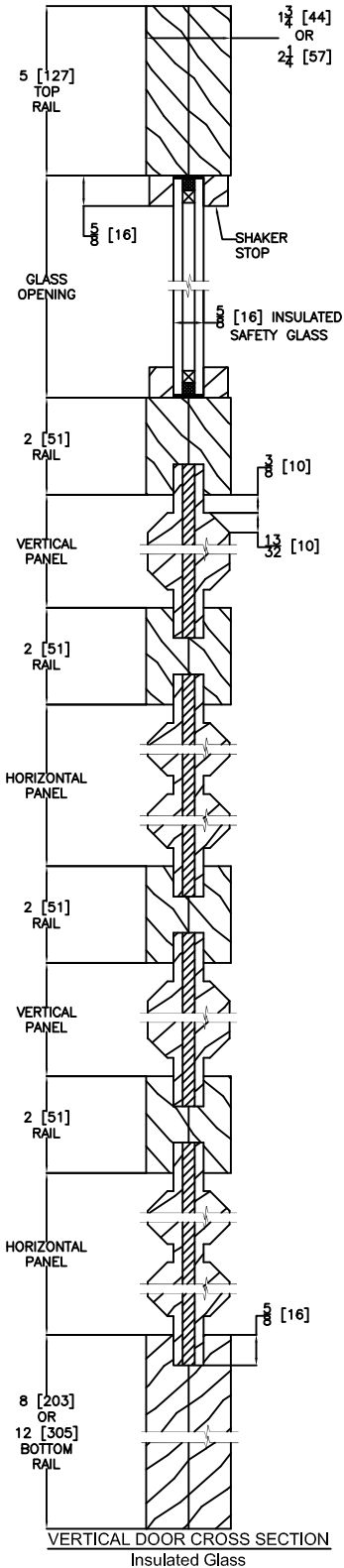

**Door Size**  
 Daylight Opening

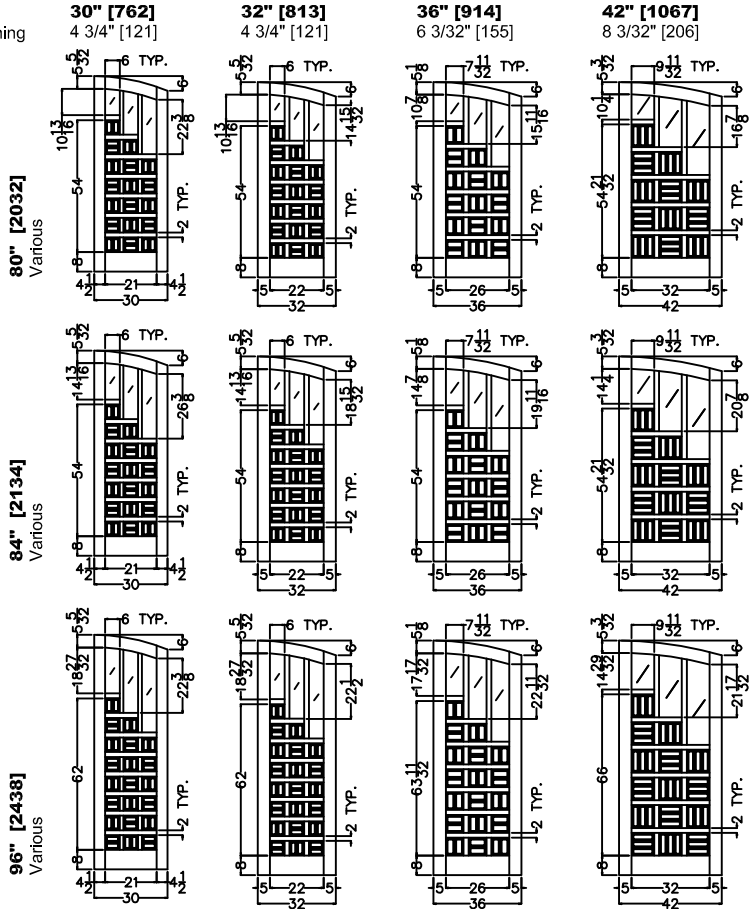

### DOOR LAYOUTS - DOUBLE DOOR

All Layouts Viewed from Exterior

#### LAYOUT 1

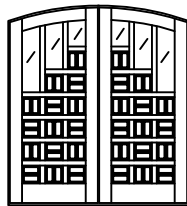

### ELEVATION NOTES

Door Size = Book Size Before Prefit  
Daylight Opening (DLO) = Visible Glass  
Values in brackets [ ] are millimeter conversions.

### DOOR CROSS-SECTION

Moulding Profile = n/a  
Panel Profile = V-Groove  
See 1322 Cross Section sheet for more detail.

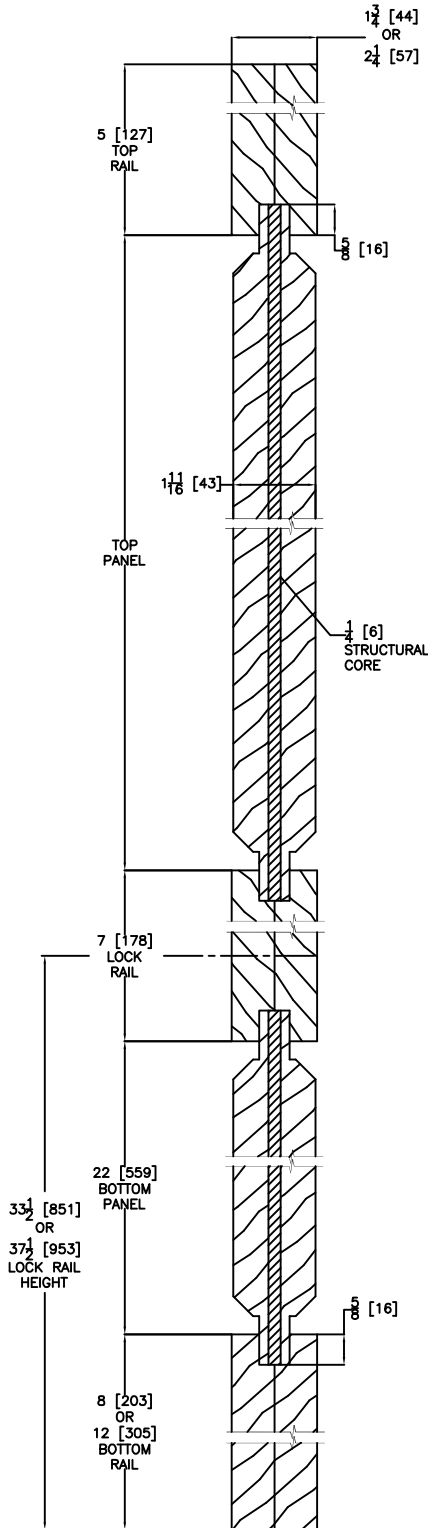

VERTICAL DOOR CROSS SECTION

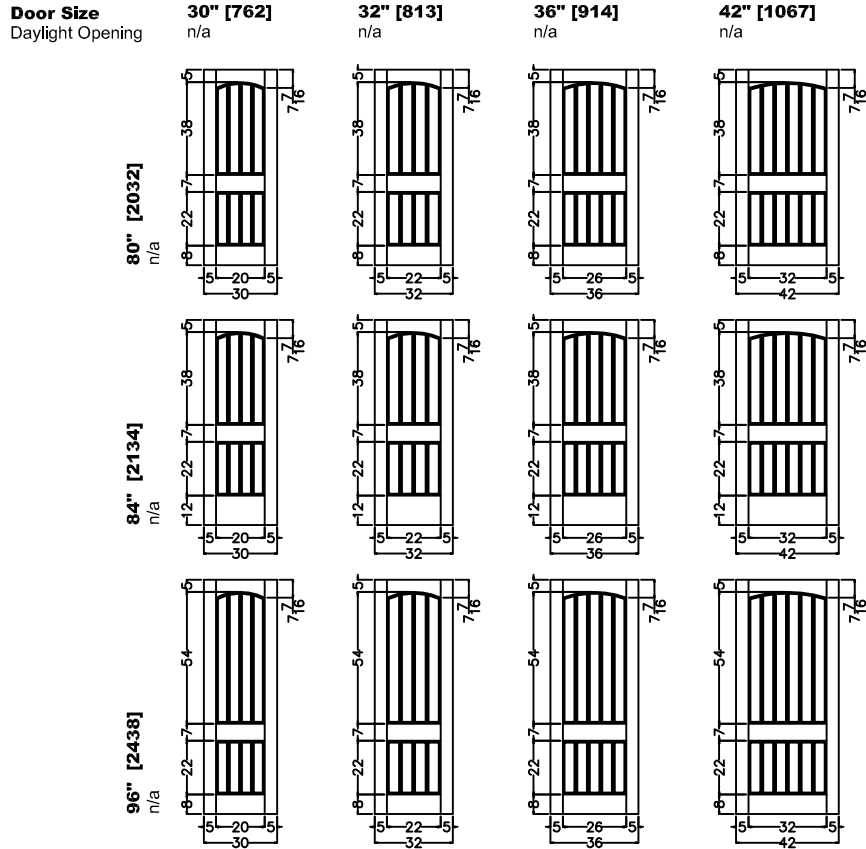

### 1" CLAVOS & STRAP PLACEMENT (Hardware Optional/Custom Placement Available)

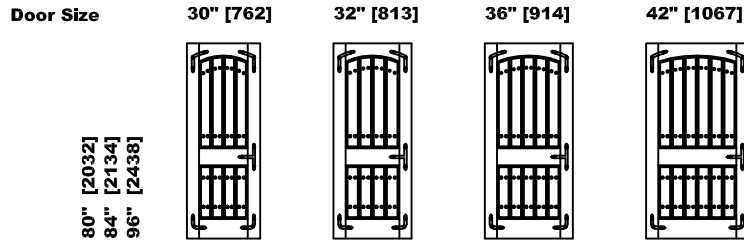

1" ROUND CLAVOS ○ ○  
OR  
1" DIAMOND CLAVOS ◆ ◆  
(Quantity & Placement Alike)

### 1.75" CLAVOS & STRAP PLACEMENT (Hardware Optional/Custom Placement Available)

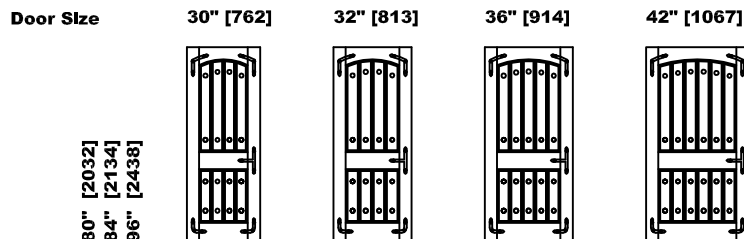

1.75" ROUND CLAVOS ○  
OR  
1.75" DIAMOND CLAVOS ◆  
(Quantity & Placement Alike)

### ELEVATION NOTES

Door Size = Book Size Before Prefit  
Daylight Opening (DLO) = Visible Glass  
Values in brackets [ ] are millimeter conversions.

### DOOR CROSS-SECTION

Moulding Profile = n/a  
Panel Profile = V-Groove  
See 1322 Cross Section sheet for more detail.

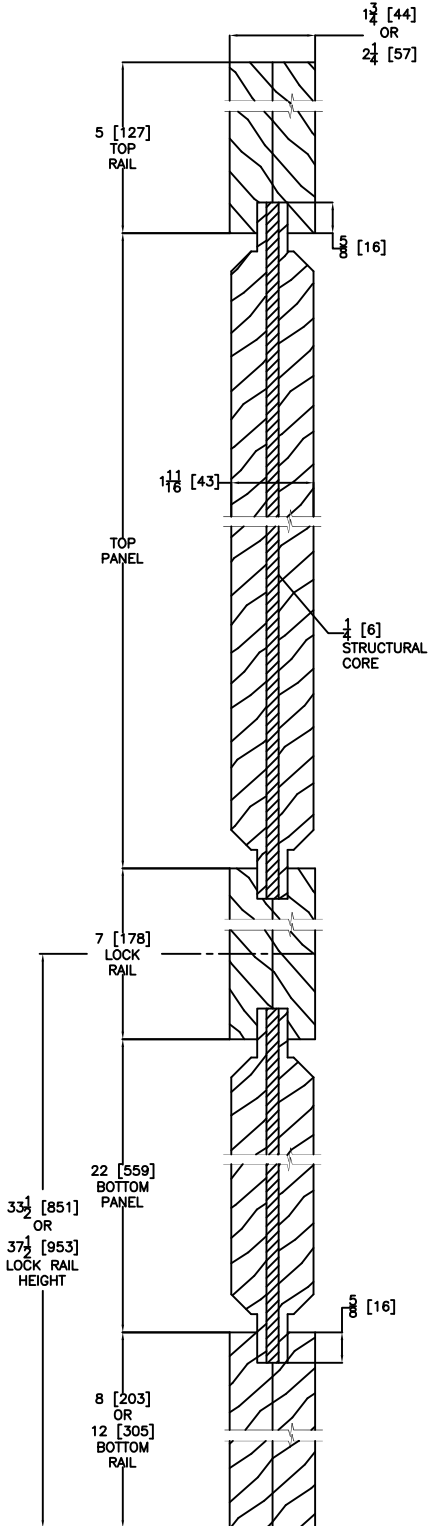

VERTICAL DOOR CROSS SECTION

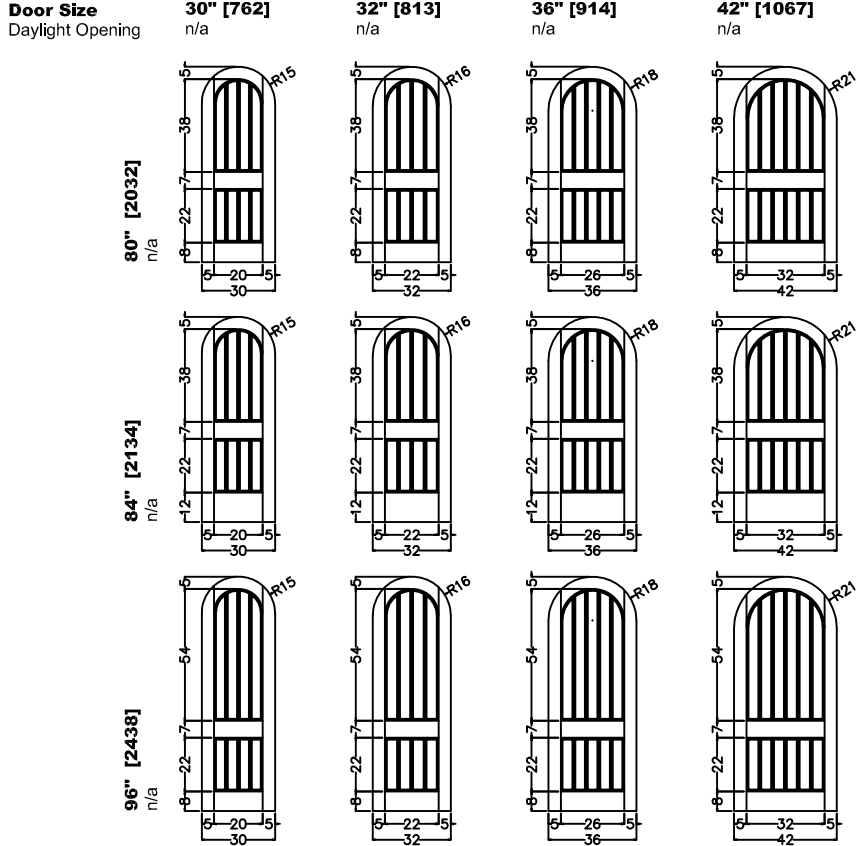

### 1" CLAVOS & STRAP PLACEMENT (Hardware Optional/Custom Placement Available)

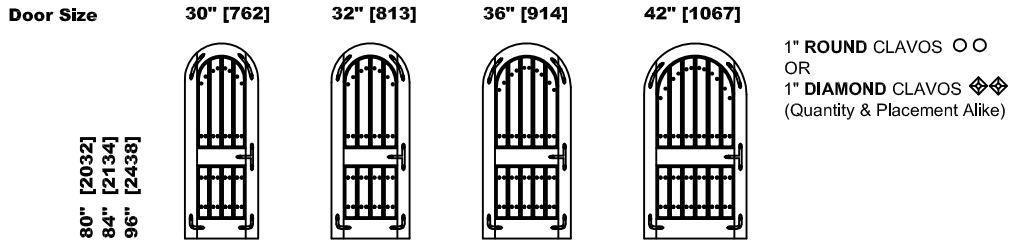

### 1.75" CLAVOS & STRAP PLACEMENT (Hardware Optional/Custom Placement Available)

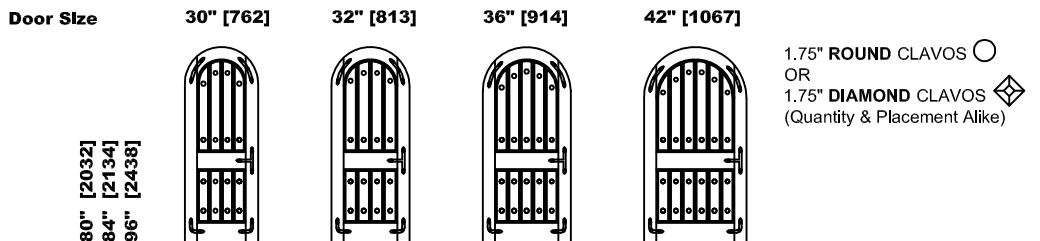

### ELEVATION NOTES

Door Size = Book Size Before Prefit  
Daylight Opening (DLO) = Visible Glass  
Values in brackets [ ] are millimeter conversions.

### DOOR CROSS-SECTION

Moulding Profile = n/a  
Panel Profile = V-Groove  
See 1322 Cross Section sheet for more detail.

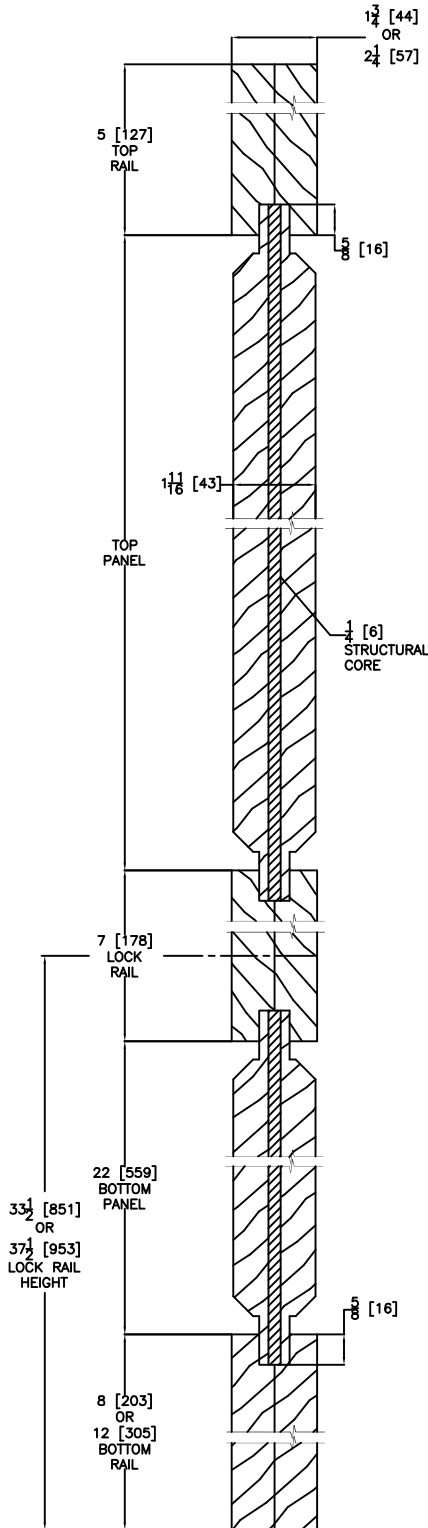

VERTICAL DOOR CROSS SECTION

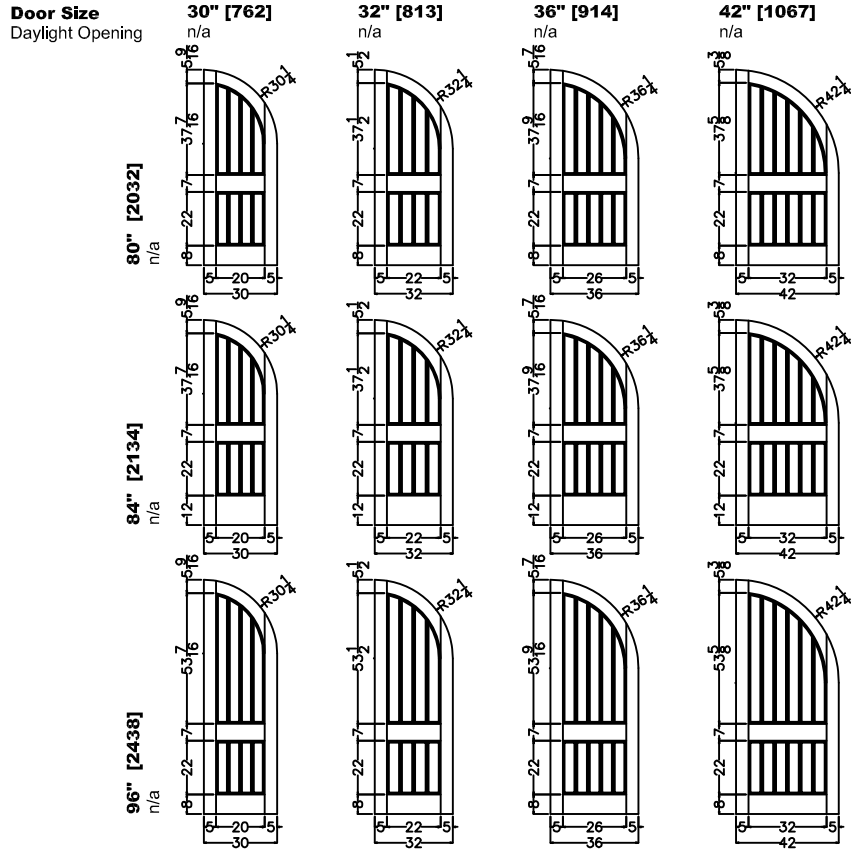

### 1" CLAVOS & STRAP PLACEMENT (Hardware Optional/Custom Placement Available)

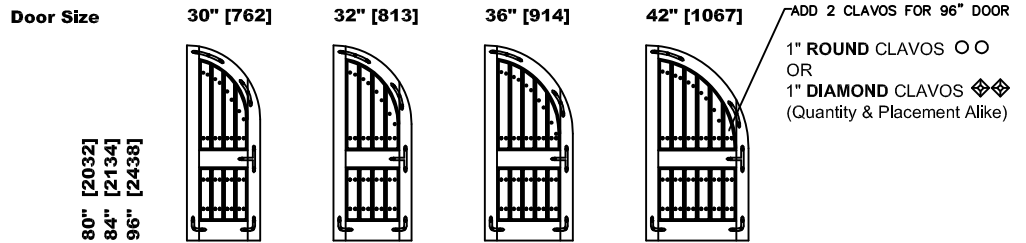

### 1.75" CLAVOS & STRAP PLACEMENT (Hardware Optional/Custom Placement Available)

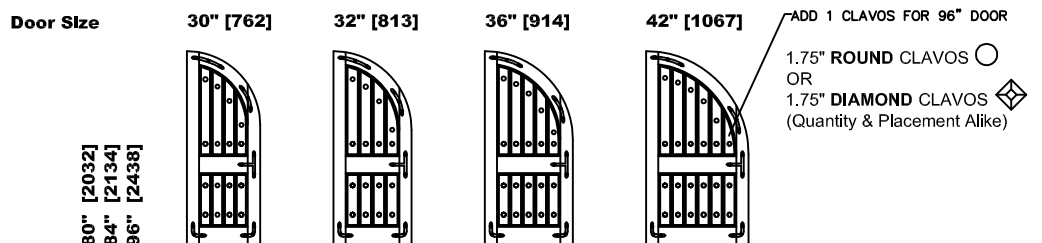

### ELEVATION NOTES

Door Size = Book Size Before Prefit  
Daylight Opening (DLO) = Visible Glass  
Values in brackets [ ] are millimeter conversions.

### DOOR CROSS-SECTION

Moulding Profile = n/a  
Panel Profile = V-Groove  
See 1322 Cross Section sheet for more detail.

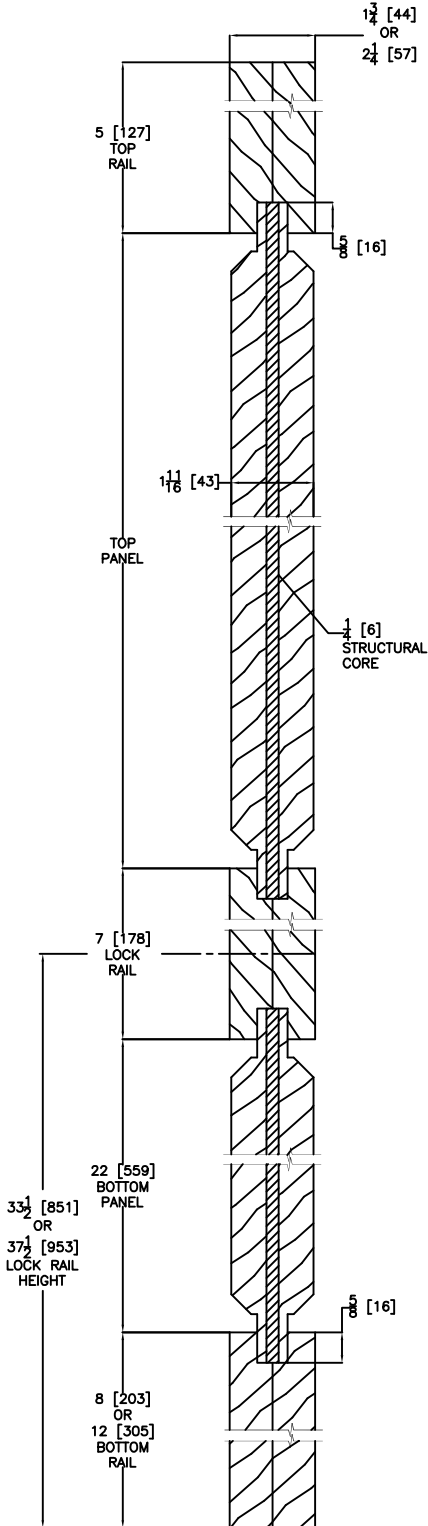

VERTICAL DOOR CROSS SECTION

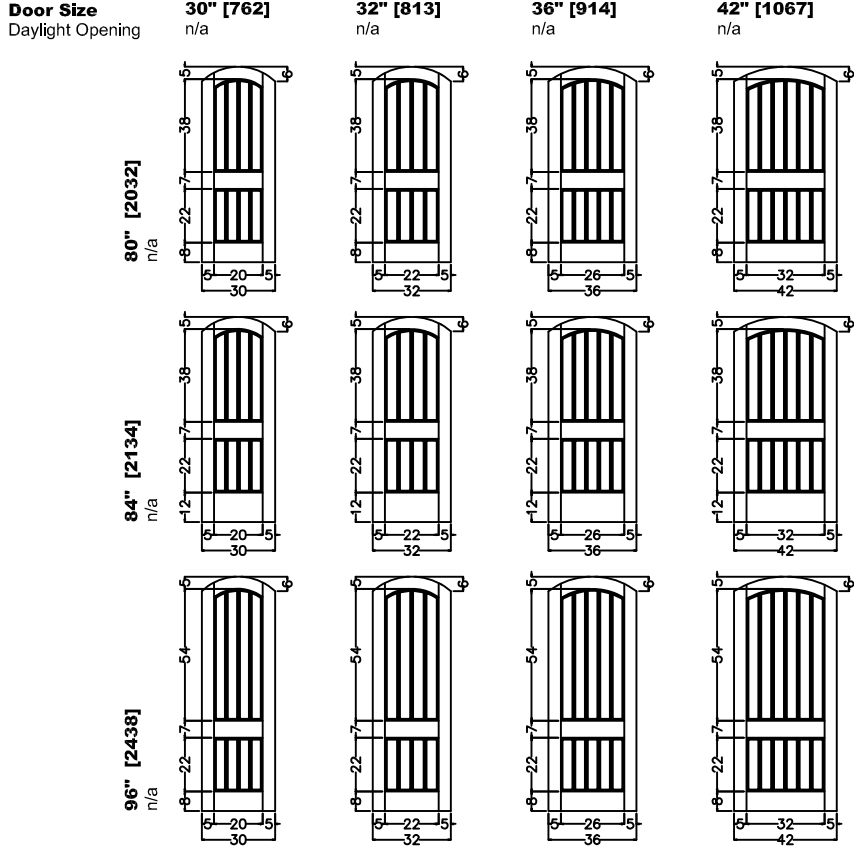

### 1" CLAVOS & STRAP PLACEMENT (Hardware Optional/Custom Placement Available)

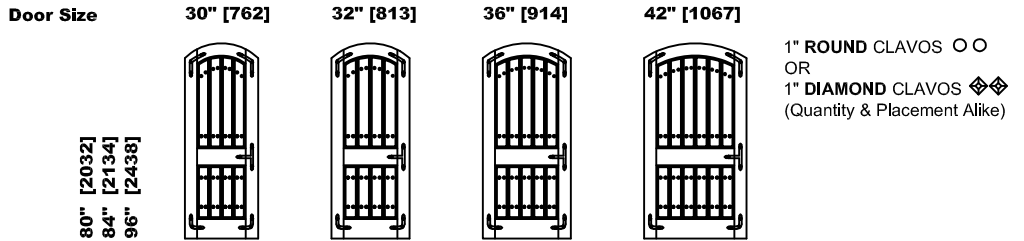

### 1.75" CLAVOS & STRAP PLACEMENT (Hardware Optional/Custom Placement Available)

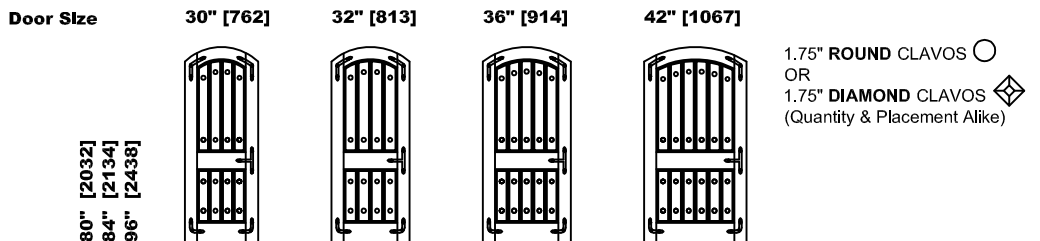

### ELEVATION NOTES

Door Size = Book Size Before Prefit  
Daylight Opening (DLO) = Visible Glass  
Values in brackets [ ] are millimeter conversions.

### DOOR CROSS-SECTION

Moulding Profile = n/a  
Panel Profile = V-Groove  
See 1322 Cross Section sheet for more detail.

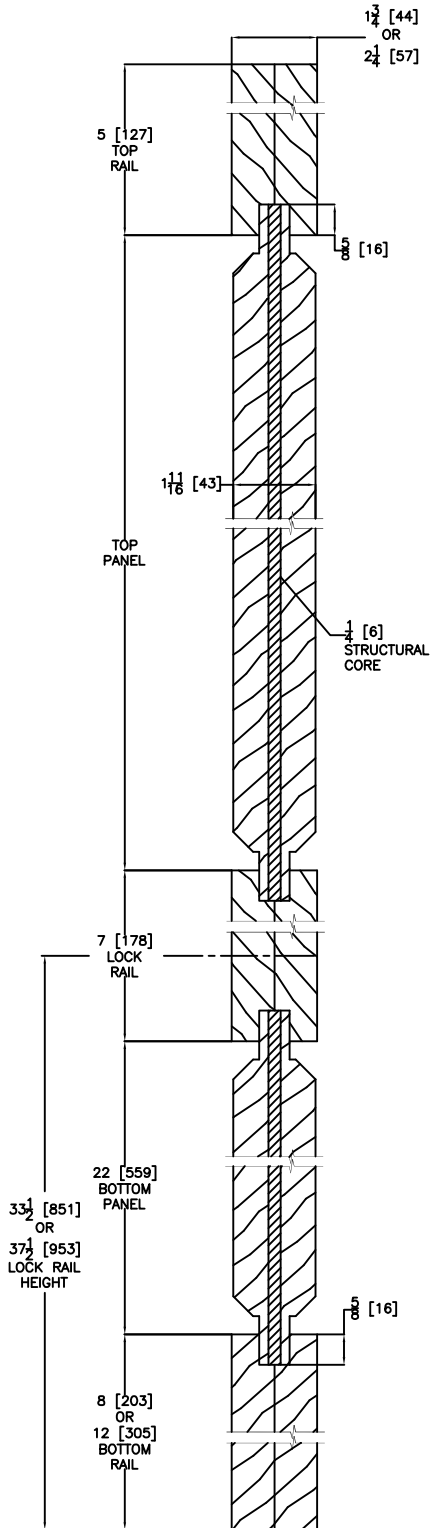

VERTICAL DOOR CROSS SECTION

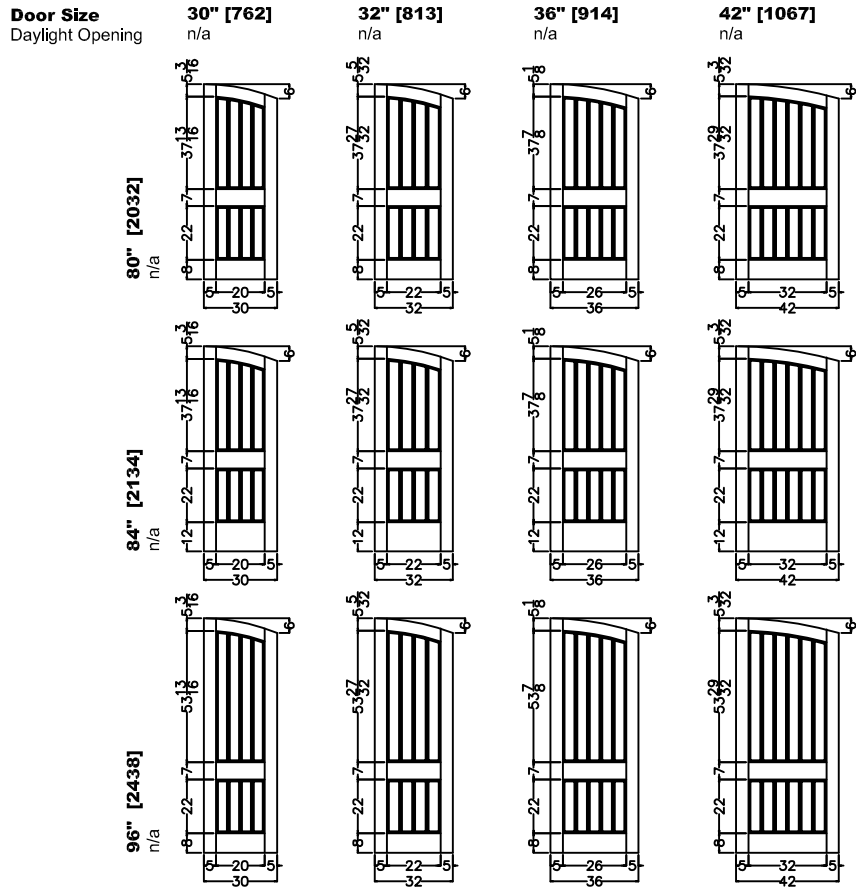

### 1" CLAVOS & STRAP PLACEMENT (Hardware Optional/Custom Placement Available)

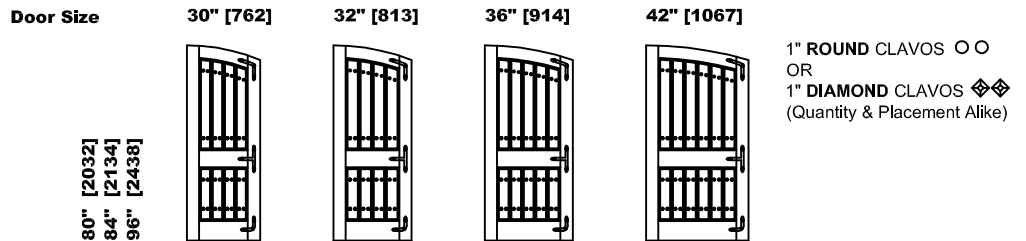

### 1.75" CLAVOS & STRAP PLACEMENT (Hardware Optional/Custom Placement Available)

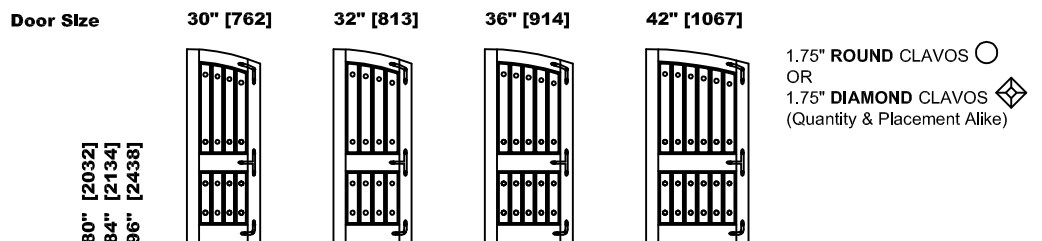

### ELEVATION NOTES

Door Size = Book Size Before Prefit  
 Daylight Opening (DLO) = Visible Glass  
 Values in brackets [ ] are millimeter conversions.

### DOOR CROSS-SECTION

Moulding Profile = Ovolo  
 Panel Profile = 45 Degree  
 See 5506 Cross Section sheet for more detail.

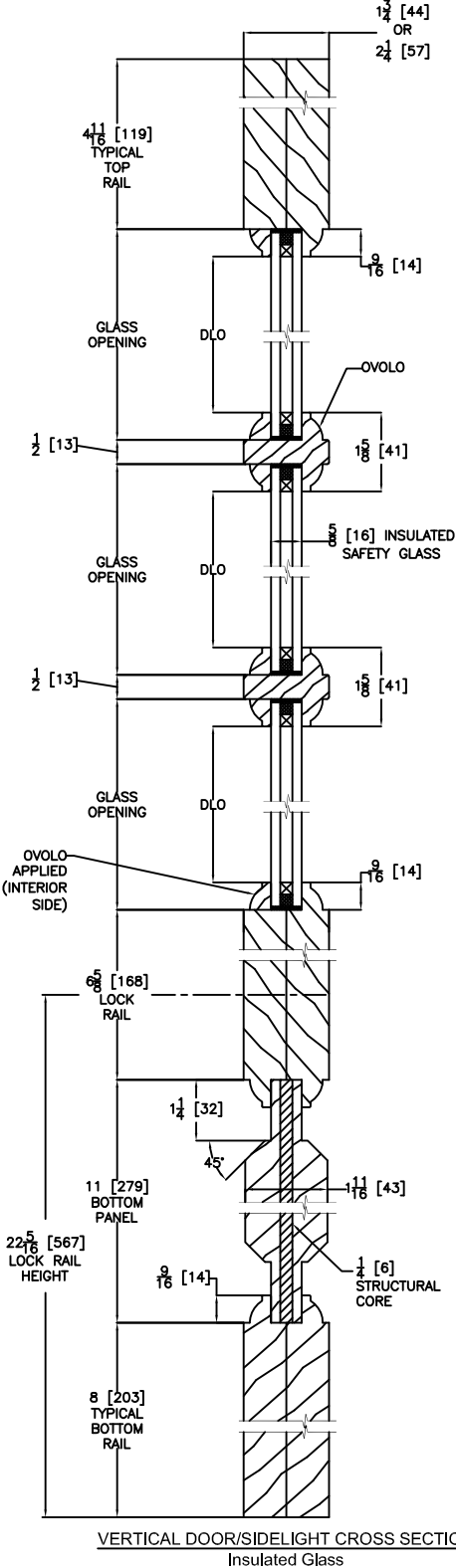

### Door Size Daylight Opening

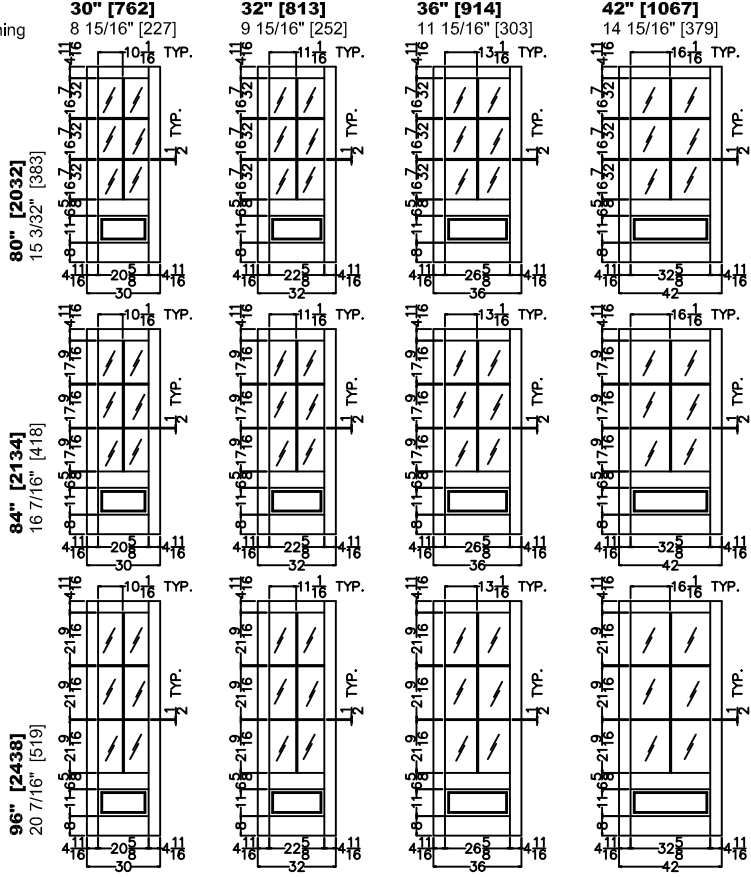

### Sidelight Size Daylight Opening

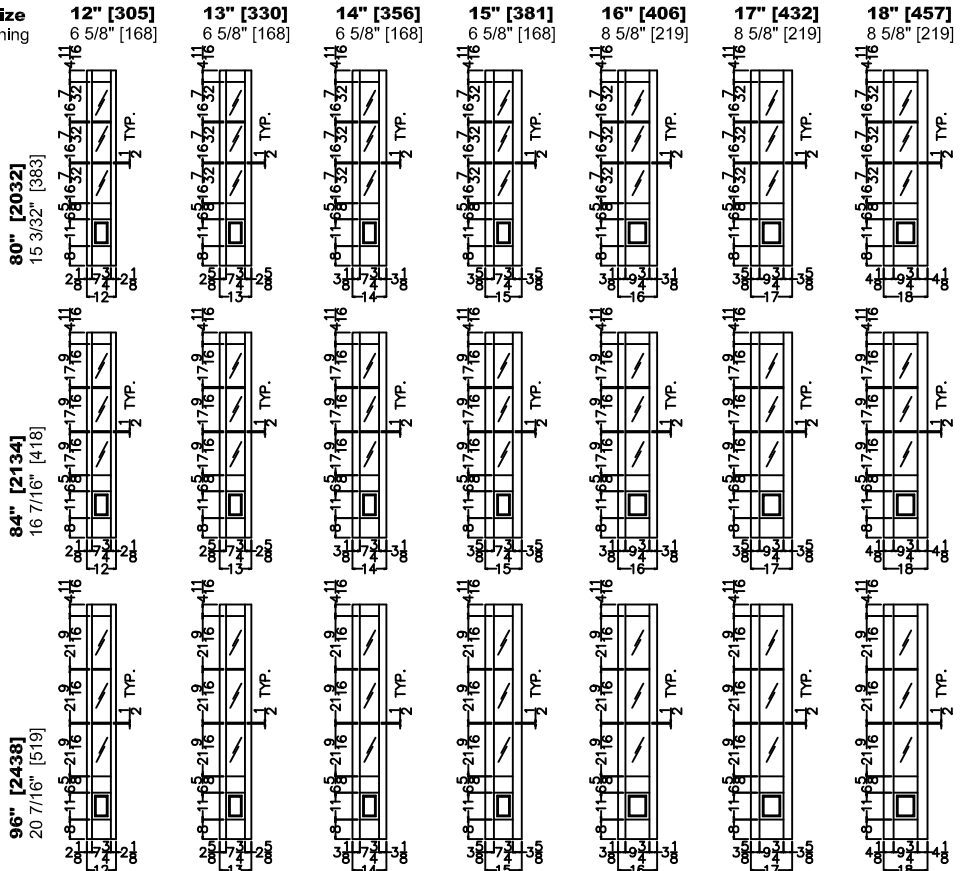

### ELEVATION NOTES

Door Size = Book Size Before Prefit  
 Daylight Opening (DLO) = Visible Glass  
 Values in brackets [ ] are millimeter conversions.

### DOOR CROSS-SECTION

Moulding Profile = Ovolo  
 Panel Profile = 45 Degree  
 See 5506 Cross Section sheet for more detail.

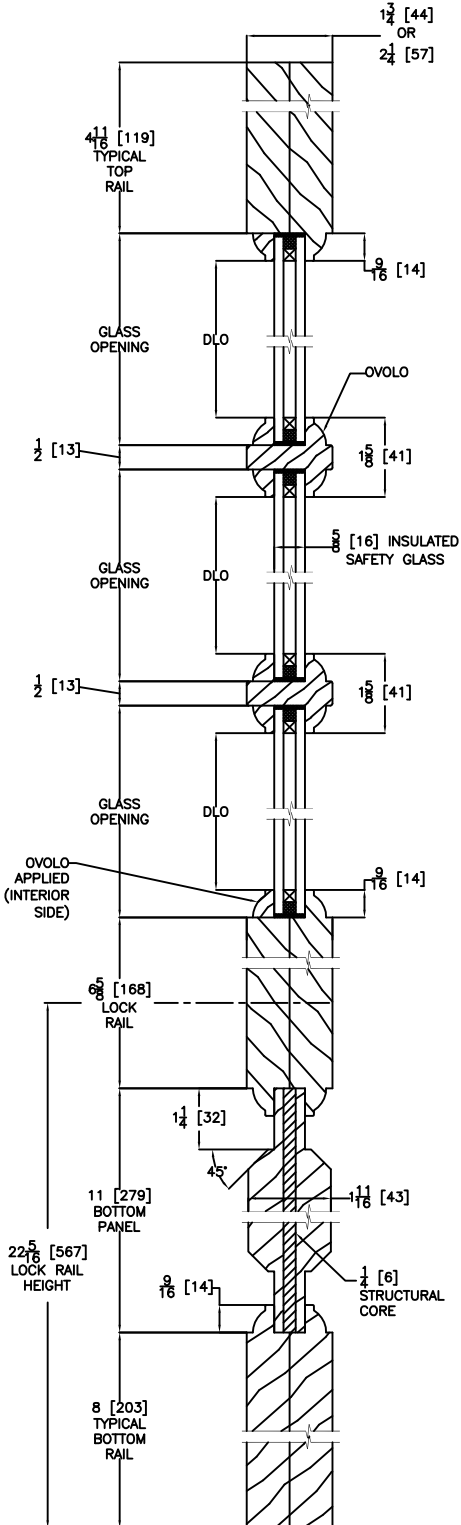

### RADIUS

**Door Size**  
 Daylight Opening

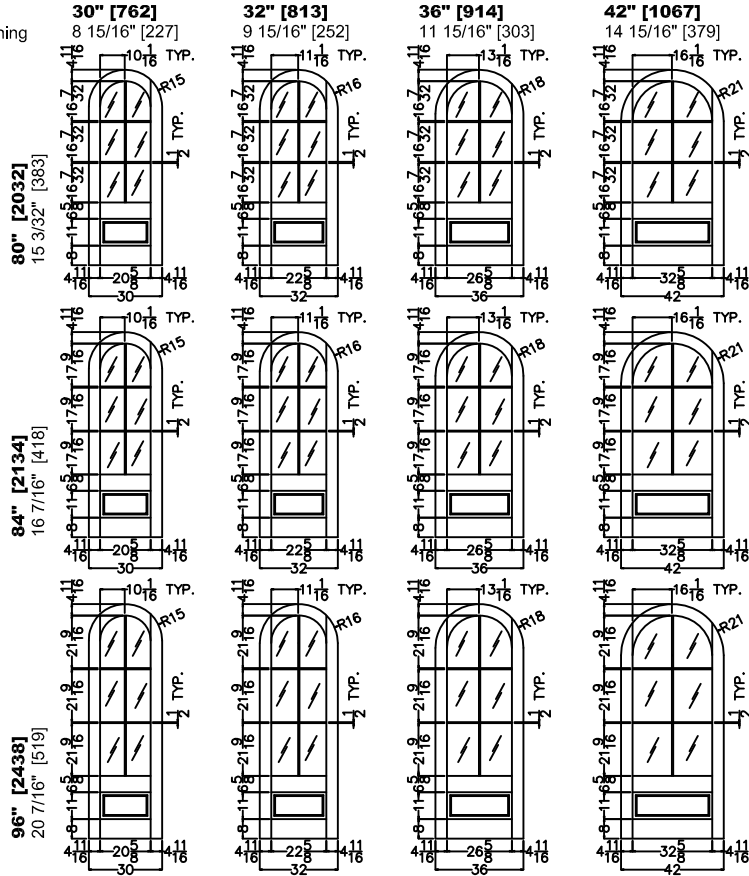

VERTICAL DOOR/SIDELIGHT CROSS SECTION  
 Insulated Glass



### ELEVATION NOTES

Door Size = Book Size Before Prefit  
 Daylight Opening (DLO) = Visible Glass  
 Values in brackets [ ] are millimeter conversions.

### DOOR CROSS-SECTION

Moulding Profile = Ovolo  
 Panel Profile = 45 Degree  
 See 5506 Cross Section sheet for more detail.

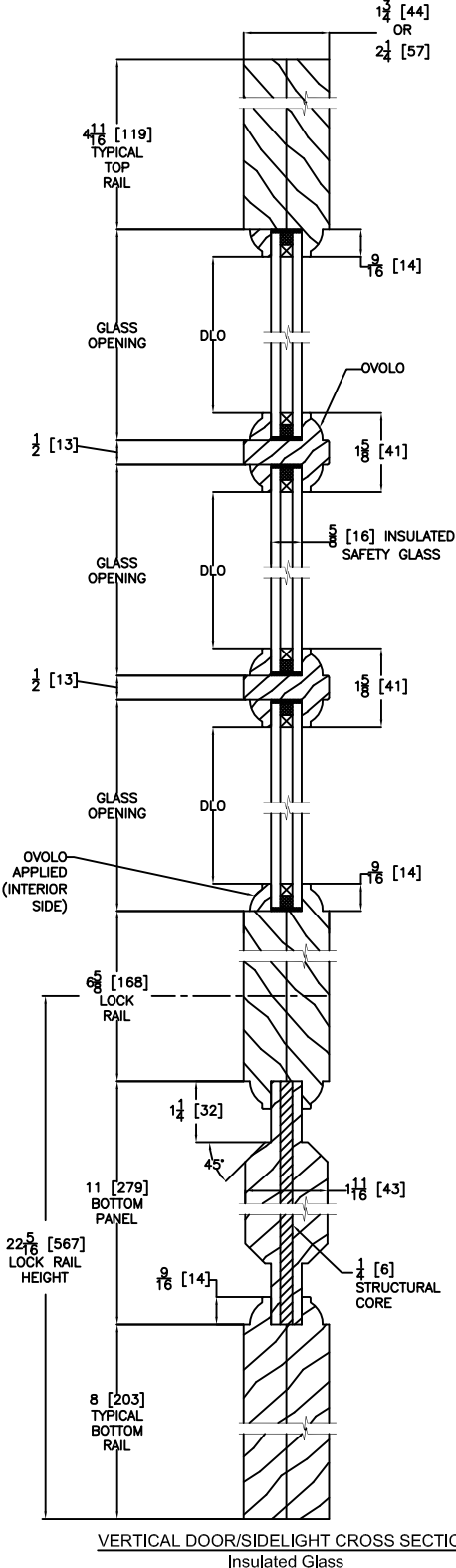

### SEGMENT

Door Size  
 Daylight Opening

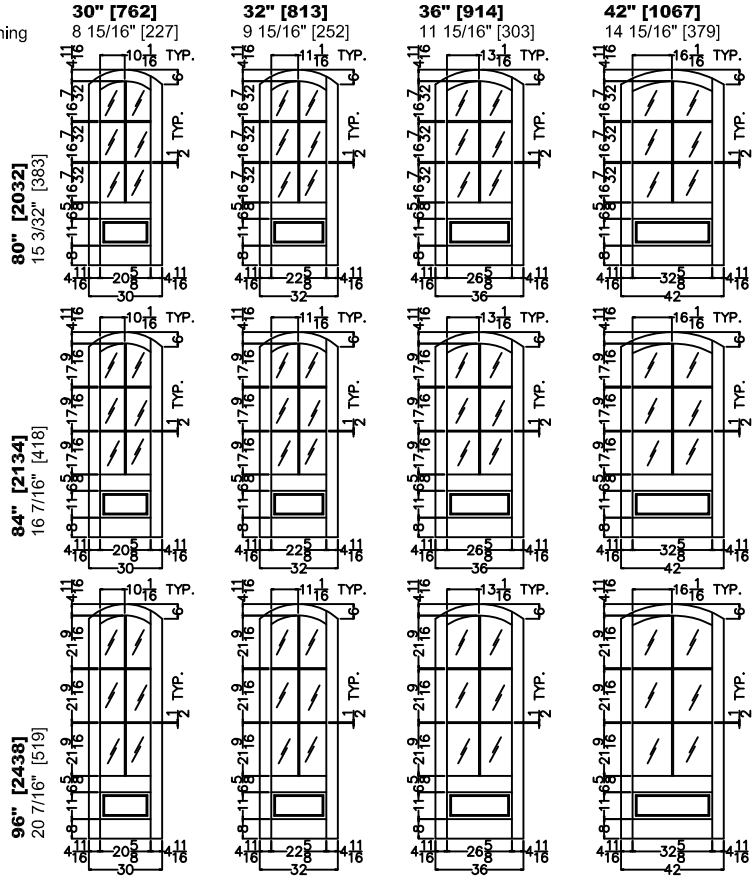

### HALF SEGMENT

Door Size  
 Daylight Opening

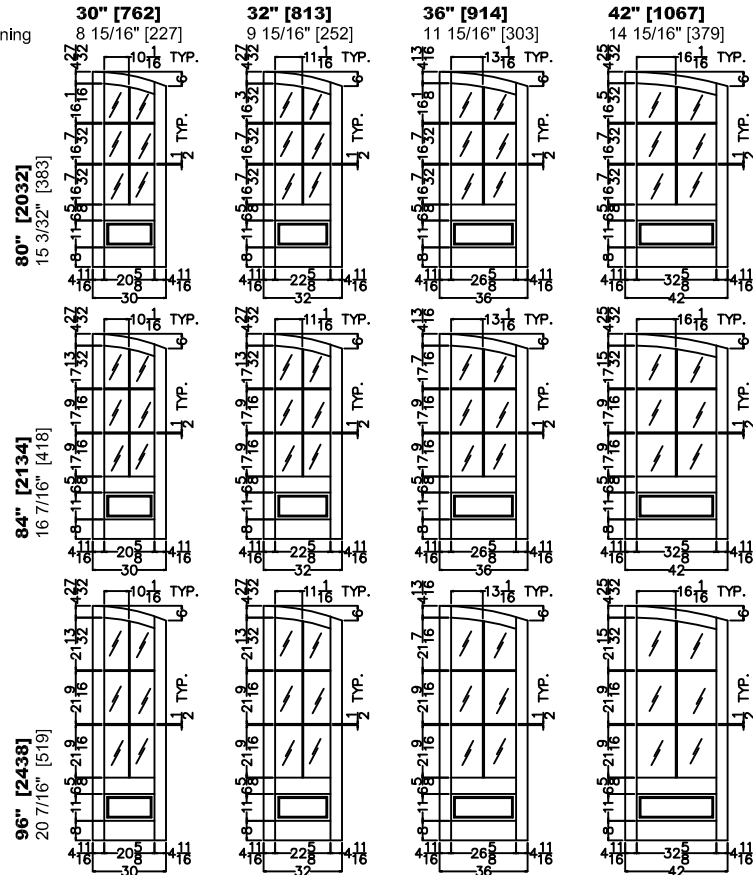

### ELEVATION NOTES

Door Size = Book Size Before Prefit  
 Daylight Opening (DLO) = Visible Glass  
 Values in brackets [ ] are millimeter conversions.

### DOOR CROSS-SECTION

Moulding Profile = Ovolo  
 Panel Profile = 45 Degree  
 See 5509 Cross Section sheet for more detail.

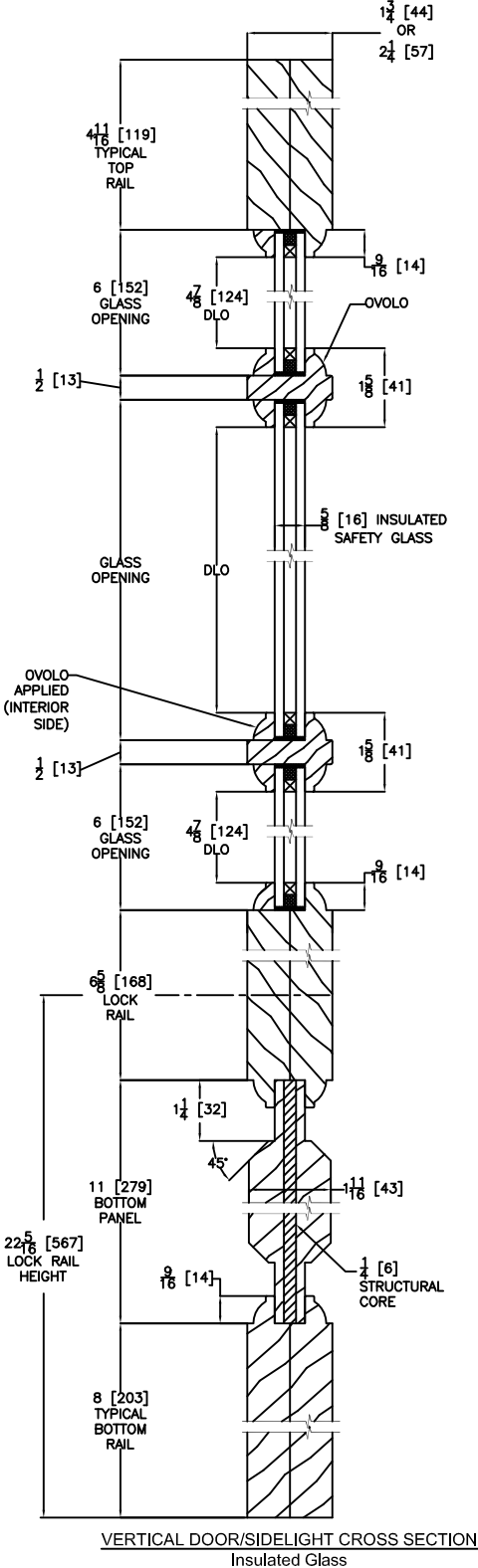

### Door Size Daylight Opening

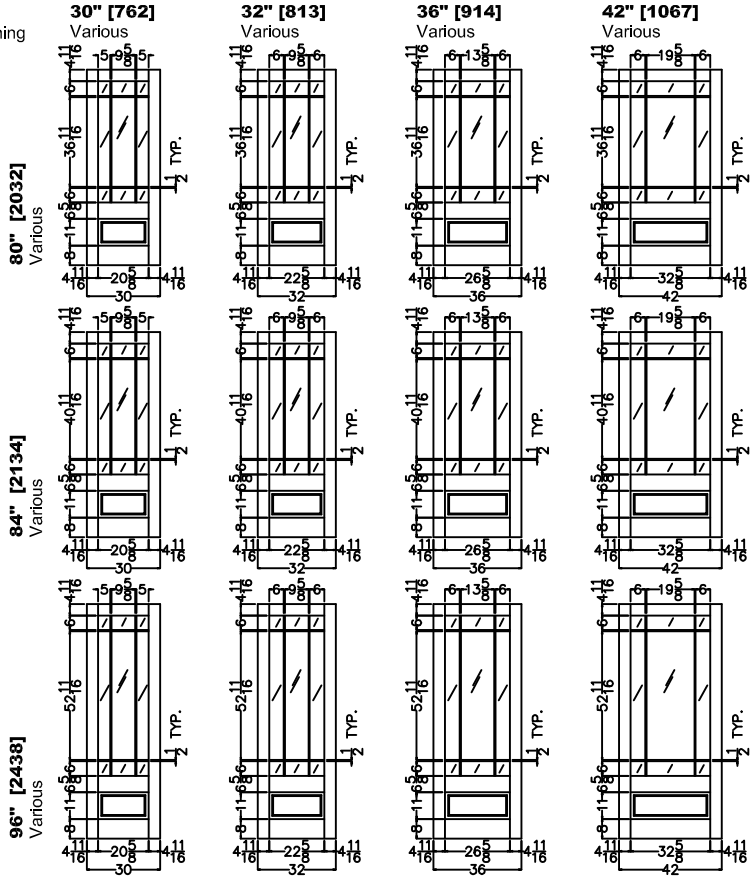

### Sidelight Size Daylight Opening

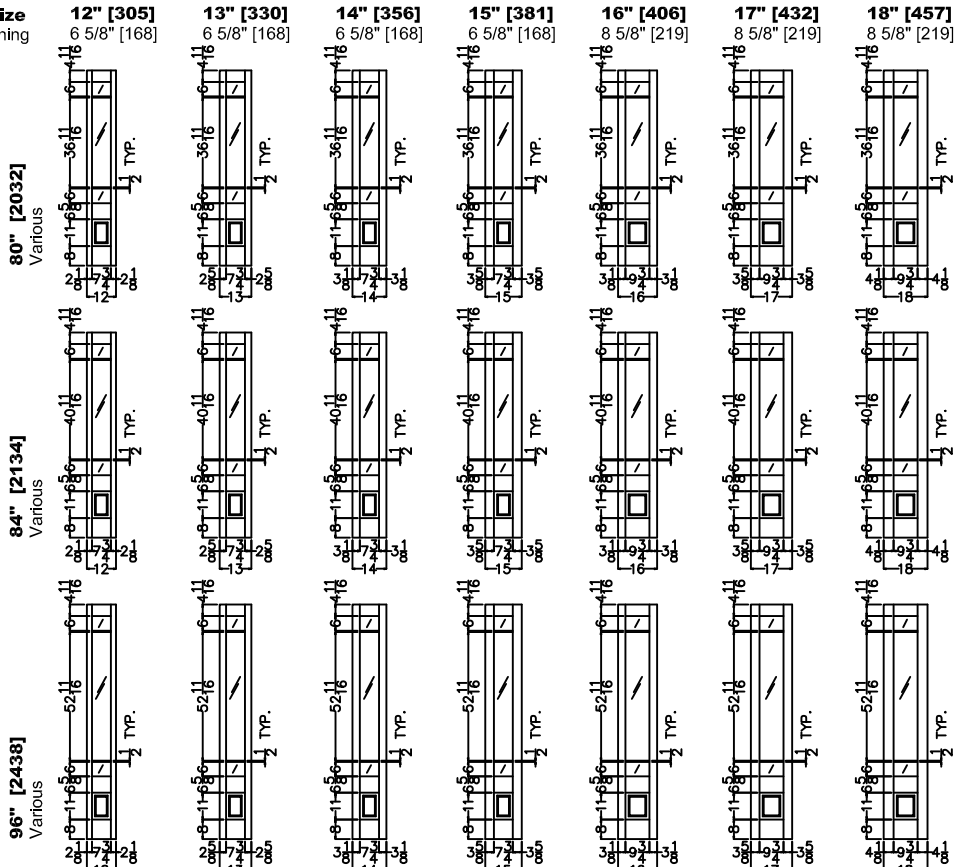

### ELEVATION NOTES

Door Size = Book Size Before Prefit  
 Daylight Opening (DLO) = Visible Glass  
 Values in brackets [ ] are millimeter conversions.

### DOOR CROSS-SECTION

Moulding Profile = Ovolo  
 Panel Profile = 45 Degree  
 See 5509 Cross Section sheet for more detail.

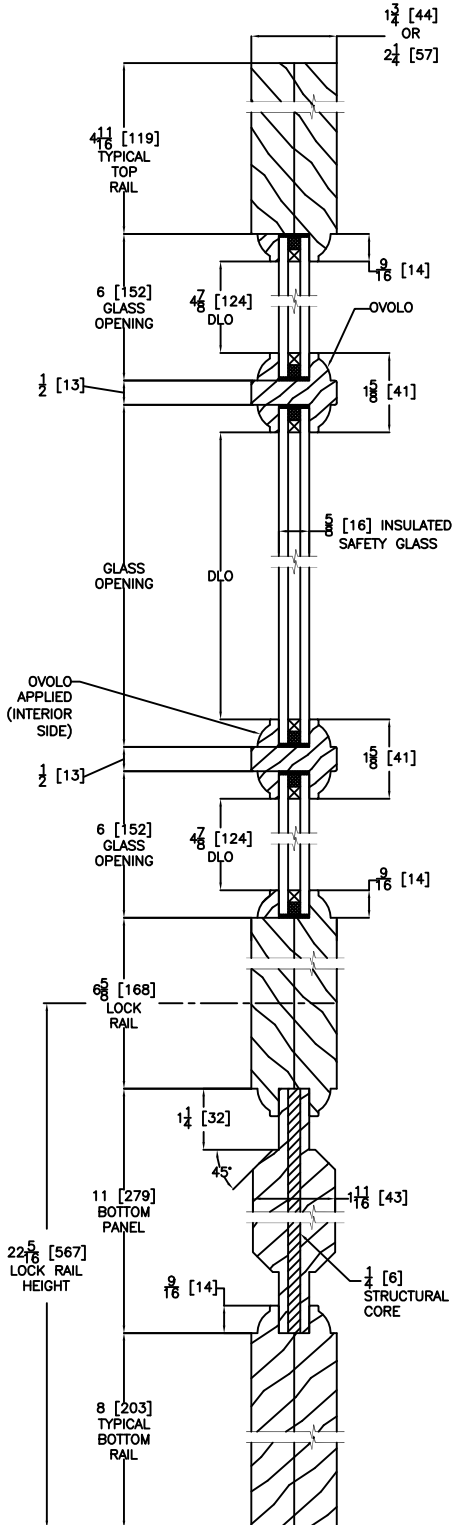

### RADIUS

**Door Size**  
 Daylight Opening

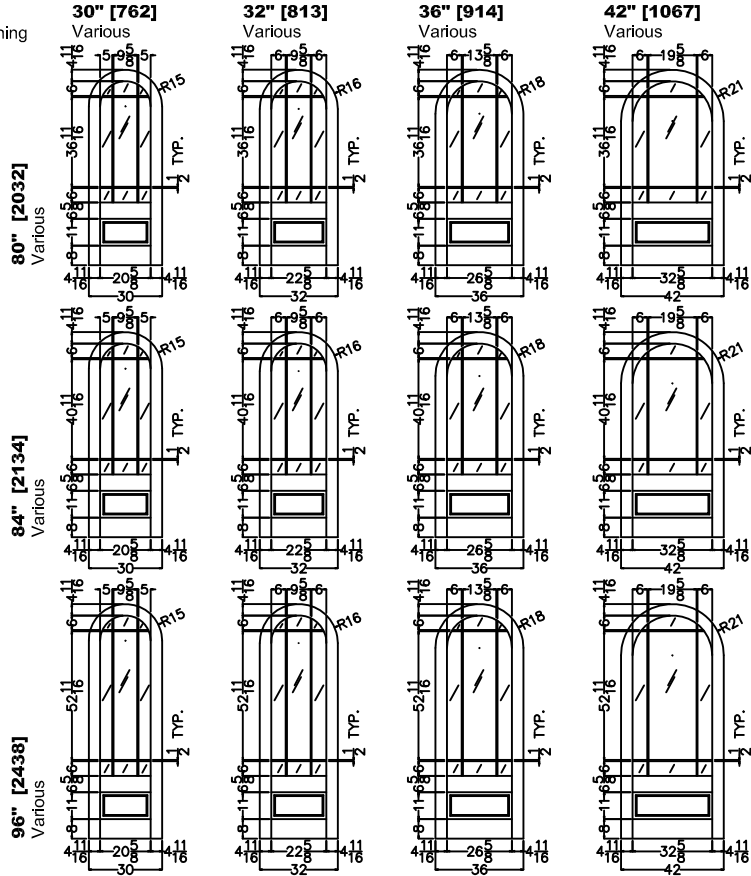

VERTICAL DOOR/SIDELIGHT CROSS SECTION  
 Insulated Glass

### ELEVATION NOTES

Door Size = Book Size Before Prefit  
 Daylight Opening (DLO) = Visible Glass  
 Values in brackets [ ] are millimeter conversions.

### DOOR CROSS-SECTION

Moulding Profile = Ovolo  
 Panel Profile = 45 Degree  
 See 5509 Cross Section sheet for more detail.

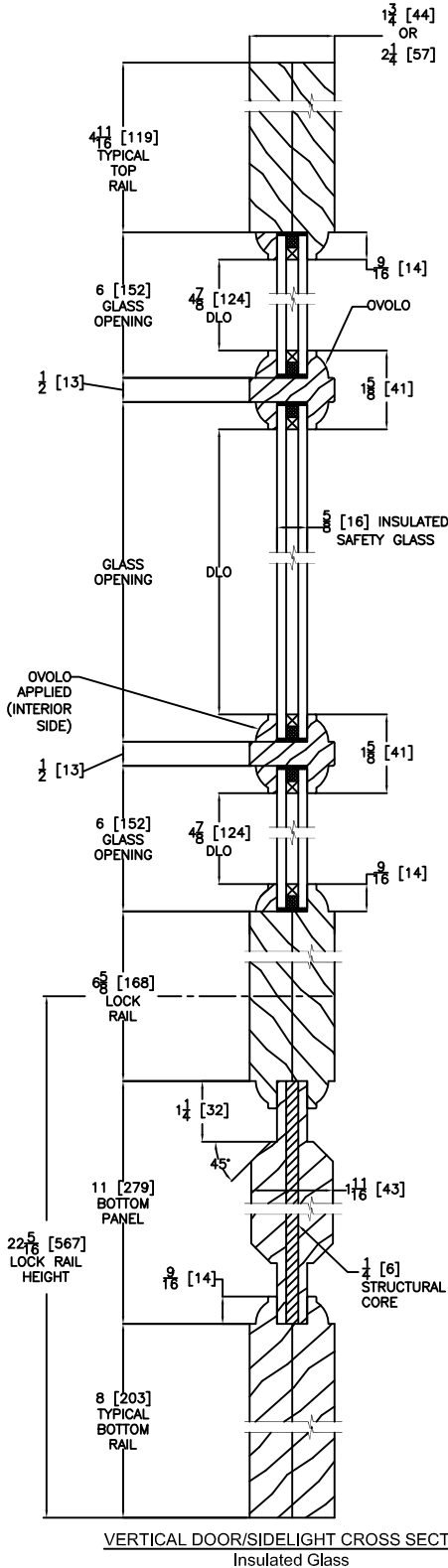

### SEGMENT

**Door Size**  
 Daylight Opening

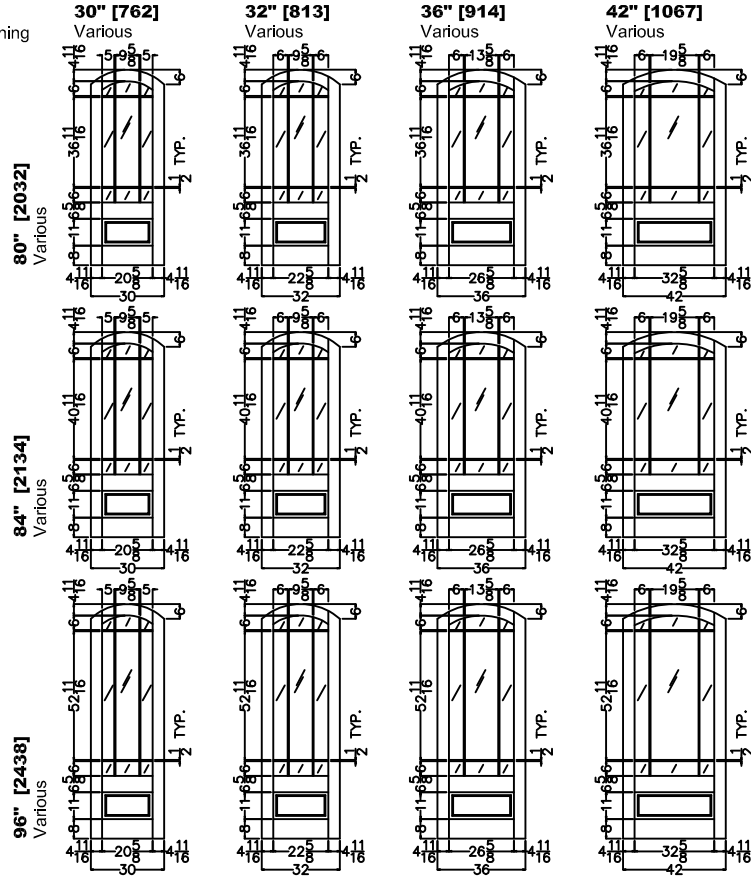

### HALF SEGMENT

**Door Size**  
 Daylight Opening

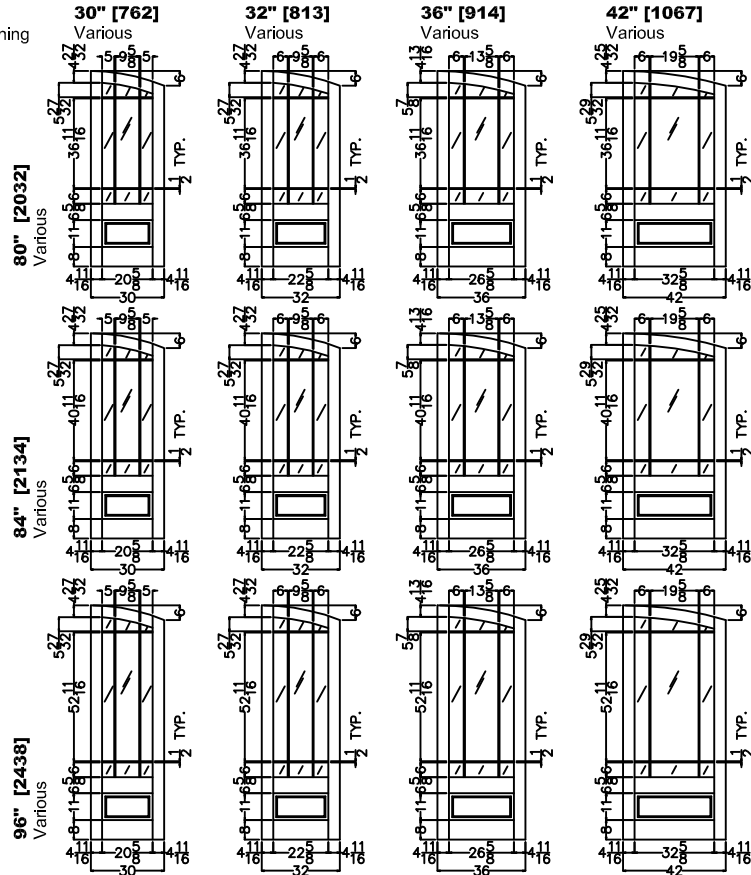

### ELEVATION NOTES

Door Size = Book Size Before Prefit  
 Daylight Opening (DLO) = Visible Glass  
 Values in brackets [ ] are millimeter conversions.

### DOOR CROSS-SECTION

Moulding Profile = Ovolo  
 Panel Profile = 45 Degree  
 See 5512 Cross Section sheet for more detail.

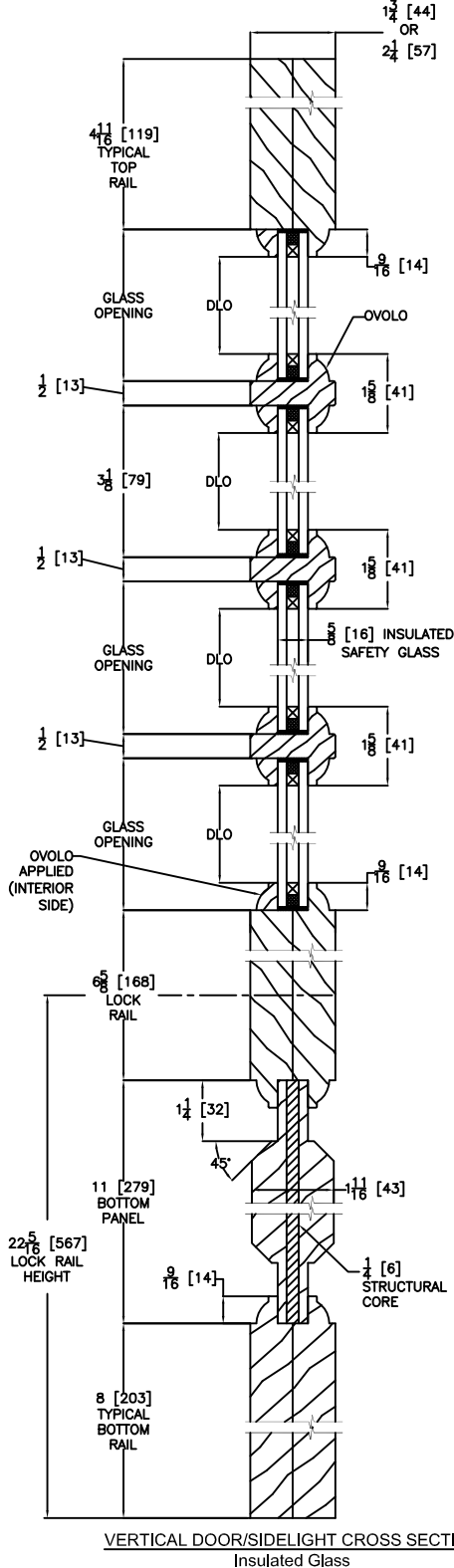

**Door Size**  
 Daylight Opening

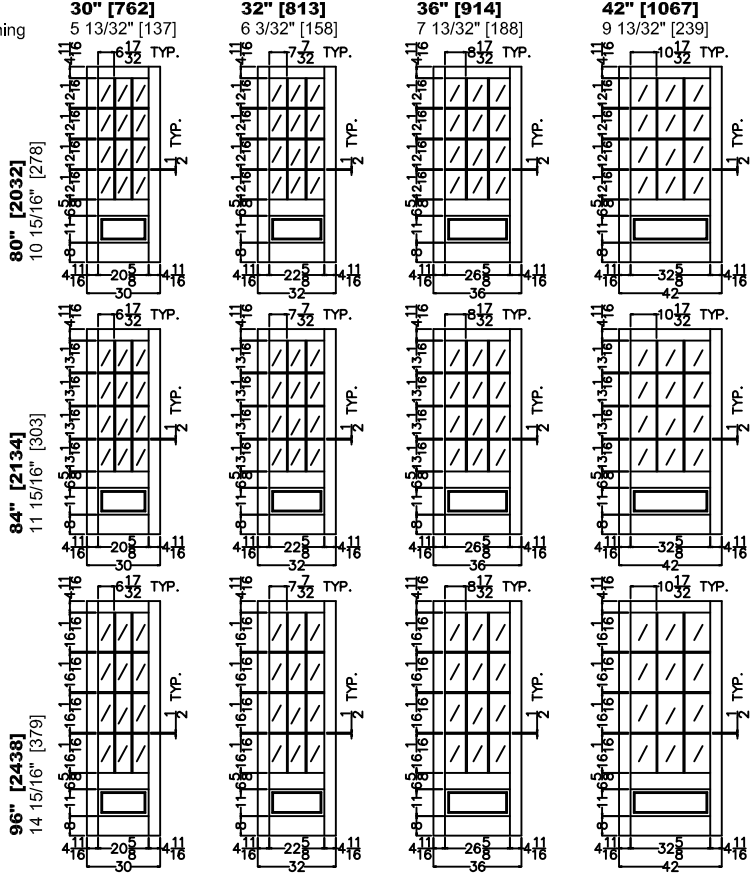

**Sidelight Size**  
 Daylight Opening

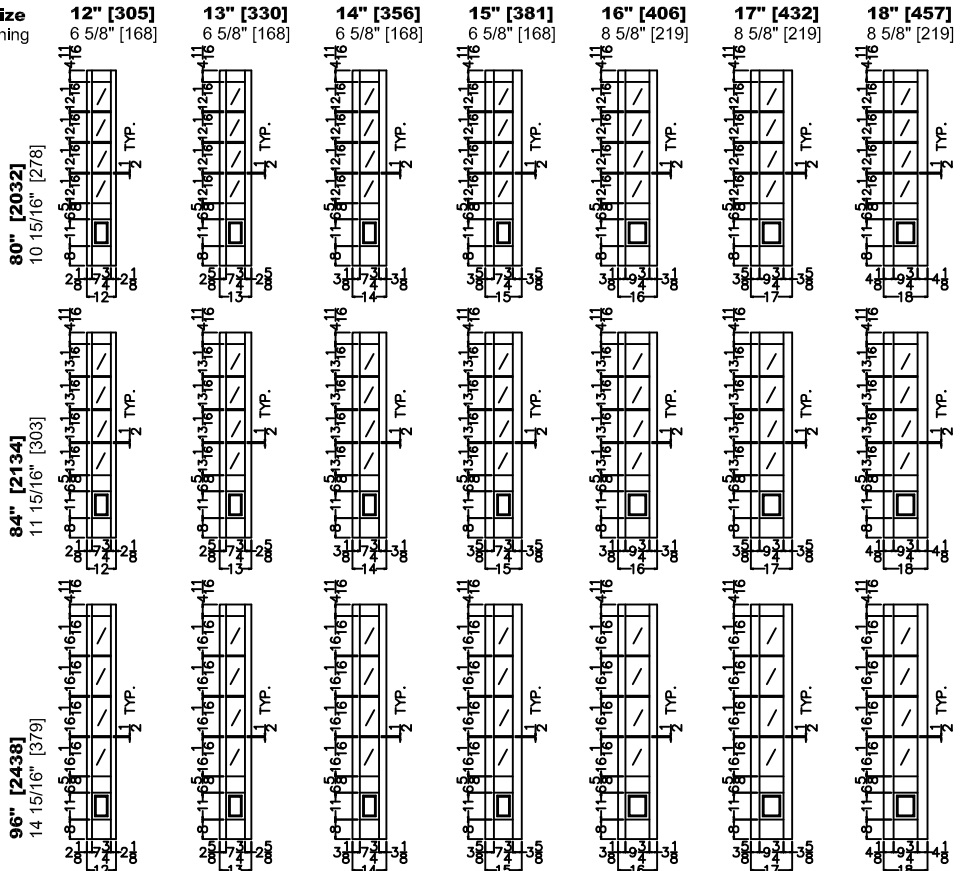

### ELEVATION NOTES

Door Size = Book Size Before Prefit  
 Daylight Opening (DLO) = Visible Glass  
 Values in brackets [ ] are millimeter conversions.

### DOOR CROSS-SECTION

Moulding Profile = Ovolo  
 Panel Profile = 45 Degree  
 See 5512 Cross Section sheet for more detail.

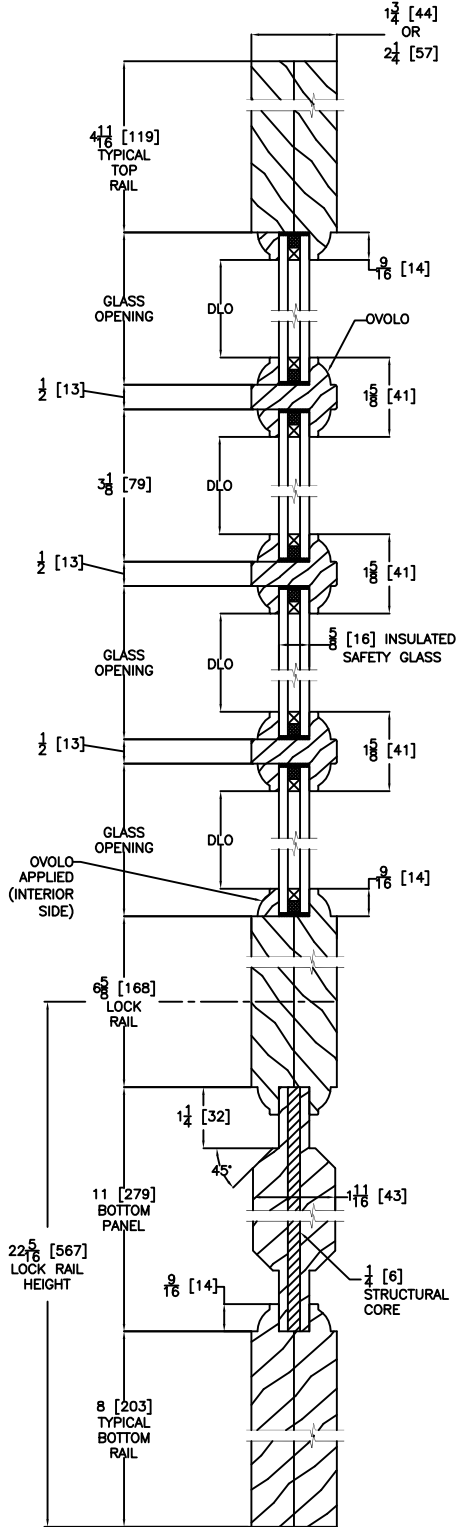

### RADIUS

Door Size  
 Daylight Opening

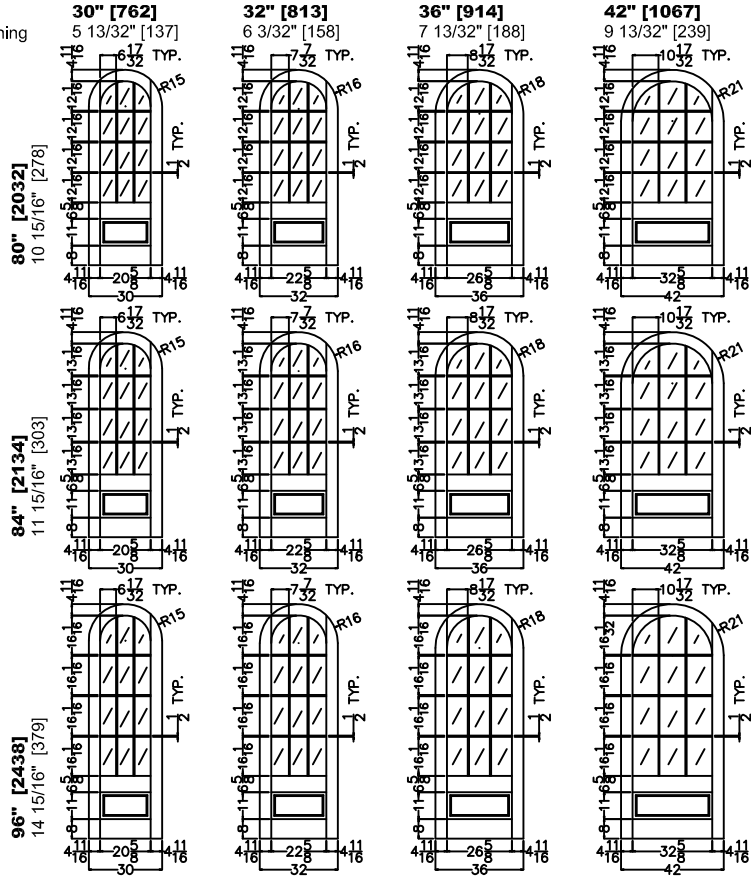

VERTICAL DOOR/SIDELIGHT CROSS SECTION  
 Insulated Glass

### ELEVATION NOTES

Door Size = Book Size Before Prefit  
 Daylight Opening (DLO) = Visible Glass  
 Values in brackets [ ] are millimeter conversions.

### DOOR CROSS-SECTION

Moulding Profile = Ovolo  
 Panel Profile = 45 Degree  
 See 5512 Cross Section sheet for more detail.

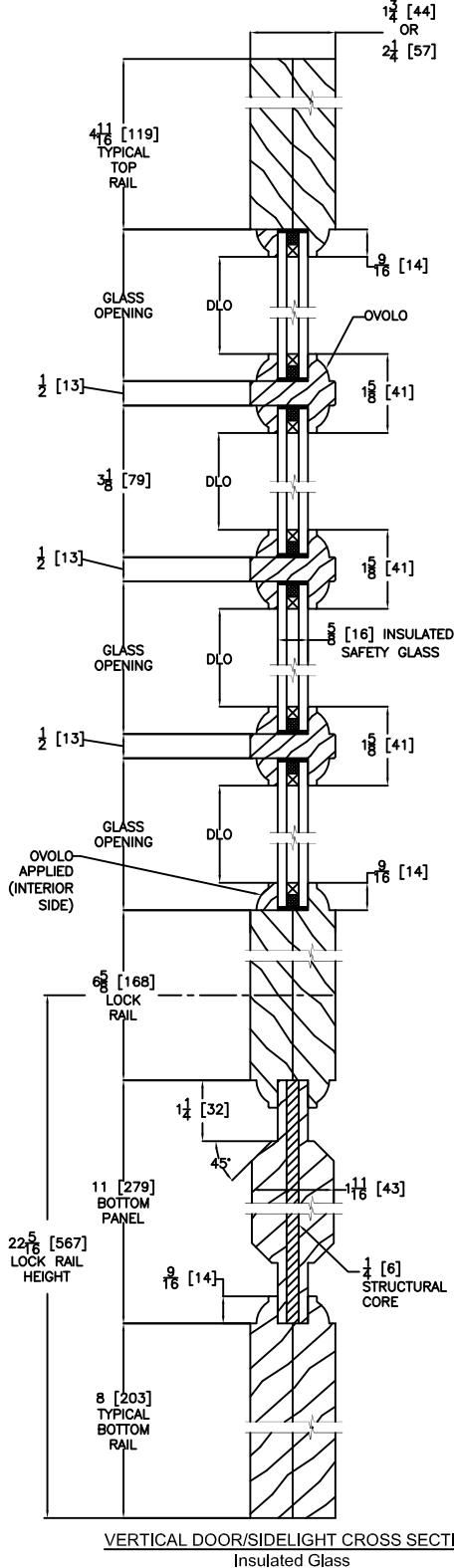

### SEGMENT

**Door Size**  
 Daylight Opening

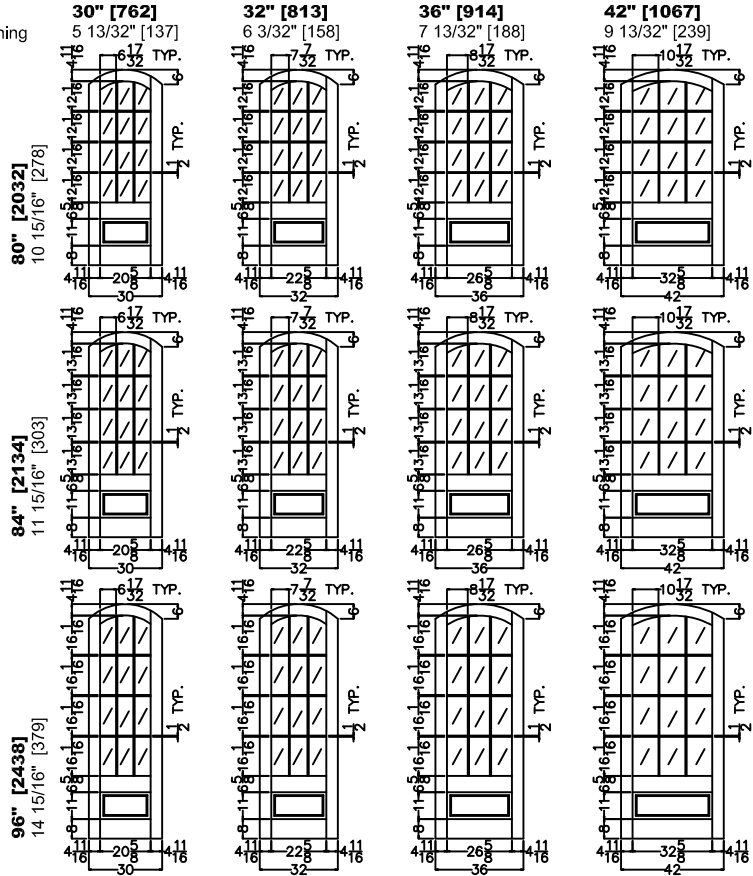

### HALF SEGMENT

**Door Size**  
 Daylight Opening

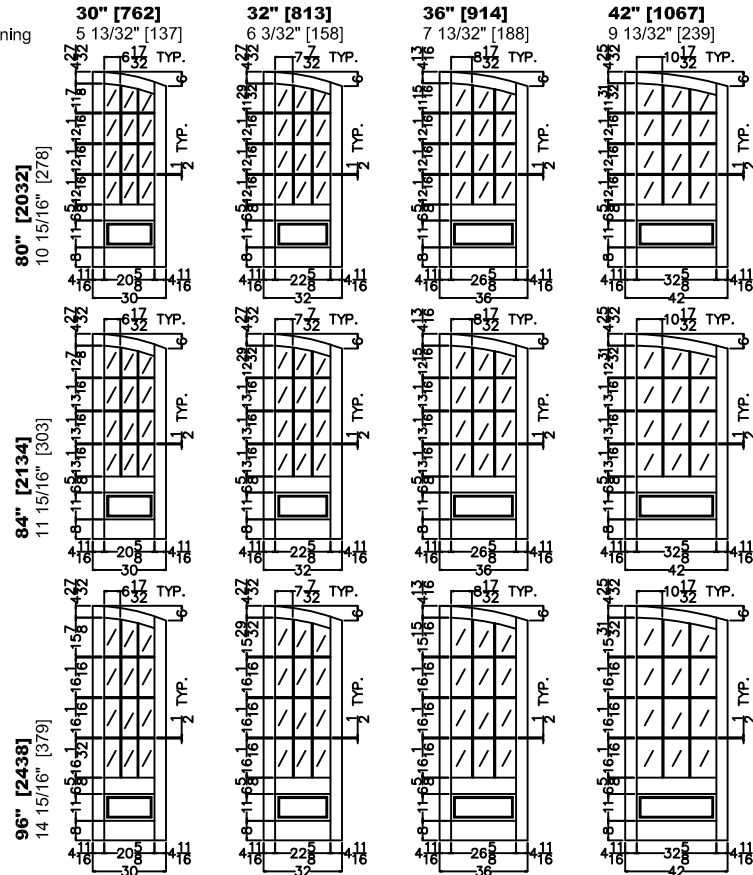

## DECORATIVE ACCENTS



### ROUND CLAVOS

Size Options: 1" diameter, 1.75" diameter  
 Finish Options: Dark Patina, Rust Patina  
 Material: Aluminum with Powder Coat Finish



### DIAMOND CLAVOS

Size Options: 1", 1.75"  
 Finish Options: Dark Patina, Rust Patina  
 Material: Aluminum with Powder Coat Finish

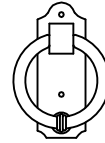

### COLONIAL DOOR KNOCKER

Base: 2" Wide x 5 5/8" Tall, Handle: 4" Wide  
 Finish Options: Dark Patina, Rust Patina  
 Material: Iron

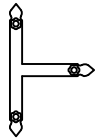

### RAIL STRAP

Finish Options: Dark Patina, Rust Patina  
 Material: Aluminum with Powder Coat Finish



### CORNER STRAP

Finish Options: Dark Patina, Rust Patina  
 Material: Aluminum with Powder Coat Finish

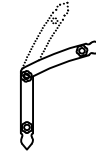

### RADIUS STRAP

Finish Options: Dark Patina, Rust Patina  
 Material: Aluminum with Powder Coat Finish  
 Adjustable for Segment/Radius Shapes

## SPEAKEASY/DOOR LIGHT

Glass Options: Clear IG, Clear SG, Bevel IG, Bevel SG, Glue Chip IG,  
 Low E IG, Rain IG, Reed IG, Frosted IG, Open for Glass  
 Handing: Will be Handed to Match the Door unless Otherwise Specified  
 Frame Size: 11 3/4" x 14 3/4", Daylight Opening: 8" x 11", Actual Glass Size: 8 7/8" x 11 7/8"

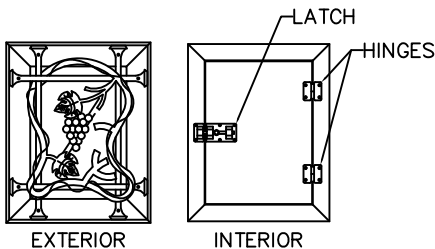

### SPEAKEASY, BORDEAUX GRILLE

Hardware Finish Options: Dark Patina, Rust Patina  
 Material: Wood Frame / Iron Hardware

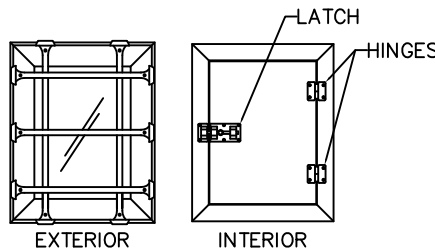

### SPEAKEASY, RUSTIC GRILLE

Hardware Finish Options: Dark Patina, Rust Patina  
 Material: Wood Frame / Iron Hardware

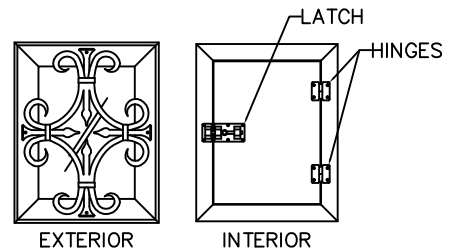

### SPEAKEASY, SEVILLE GRILLE

Hardware Finish Options: Dark Patina, Rust Patina  
 Material: Wood Frame / Iron Hardware

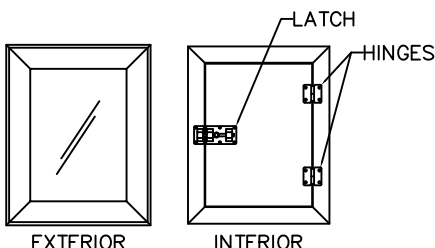

### SPEAKEASY (NO GRILLE)

Hardware Finish Options: Dark Patina, Rust Patina  
 Material: Wood Frame / Iron Hardware

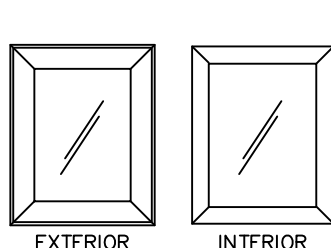

### RECTANGLE DOOR LIGHT

Hardware Finish Options: n/a  
 Material: Wood Frame  
 Available with All Speakeasy Grilles

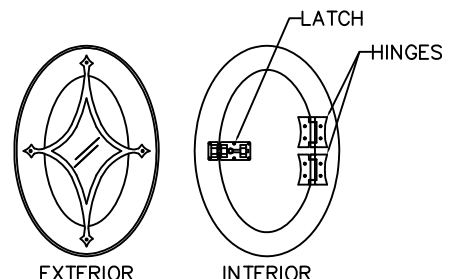

### OVAL SPEAKEASY, VICTORIAN GRILLE

Hardware Finish Options: Dark Patina, Rust Patina  
 Material: Wood Frame / Iron Hardware  
 Frame Size: 12" x 17 1/2"





**#20 CASING**  
2 1/4" X 1 1/8"



**#20 w/ STUCCO KEY**  
2 1/4" X 1 1/8"



**#22 CASING**  
2" X 1 1/8"

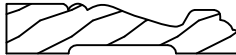

**#13 CASING**  
3 1/2" X 3/4"



**#14 CASING**  
2 1/4" X 3/4"

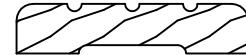

**#15 CASING**  
3 1/2" X 3/4"



**#16 CASING**  
2 1/4" X 3/4"



**#17 CASING**  
4 1/2" X 1 3/16"

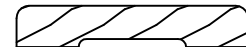

**#21 CASING**  
3 1/2" X 5/8"



**#23 CASING**  
3 1/2" X 1 1/8"

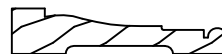

**#24 CASING**  
3 1/4" X 11/16"

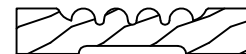

**#25 CASING**  
3 1/2" X 11/16"

**Notes:**

Shown here are standard trim options.

Special size casing or custom profile casing may be available upon request.

EXTERIOR CORNER BLOCK

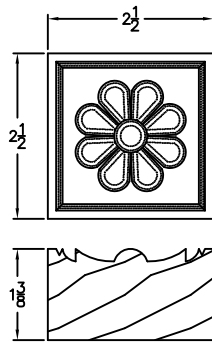

"A" BLOCK  
2 1/2" X 2 1/2"

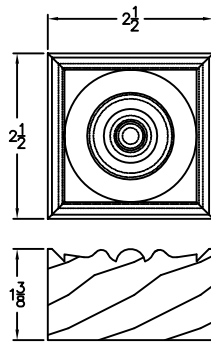

"B" BLOCK  
2 1/2" X 2 1/2"

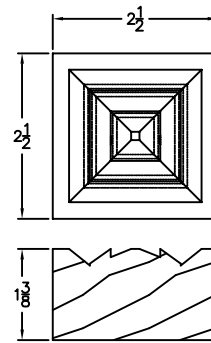

"C" BLOCK  
2 1/2" X 2 1/2"

INTERIOR CORNER BLOCK

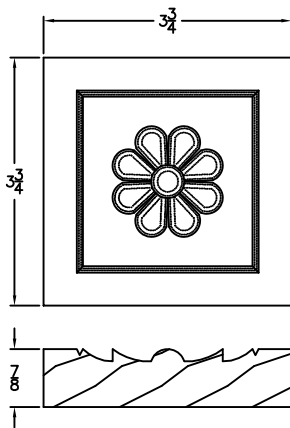

"A" BLOCK  
3 3/4" X 3 3/4"

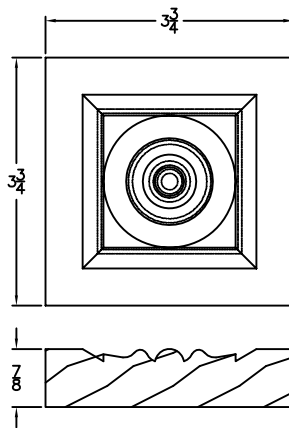

"B" BLOCK  
3 3/4" X 3 3/4"

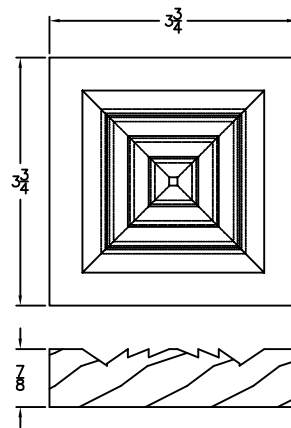

"C" BLOCK  
3 3/4" X 3 3/4"

**Notes:**

Interior corner block may be used for exterior application and vice versa.

### INSULATED GLASS

- Clear Safety
- Clear Beveled
- Glue Chip
- Low-E
- Rain
- Reed
- Frosted

### TRIPLE GLAZED

A - Q

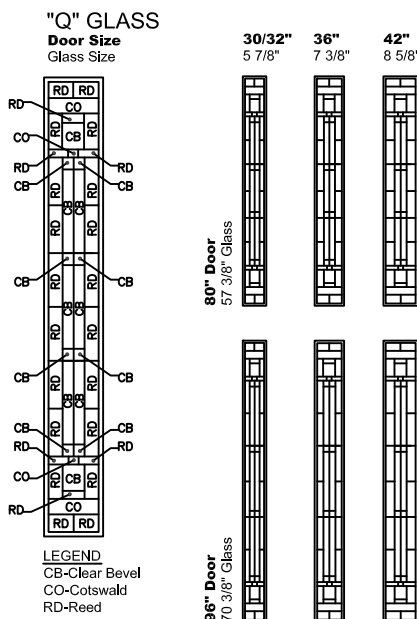
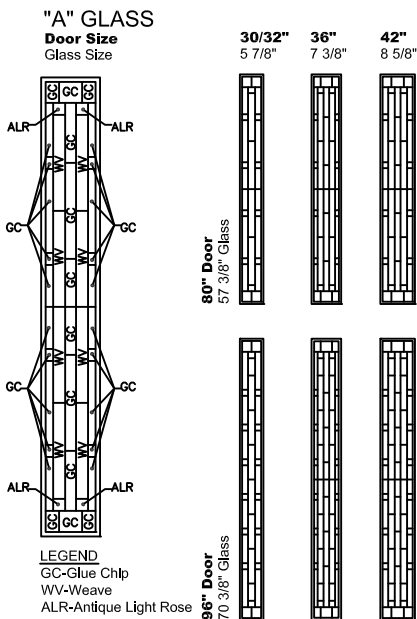

### INSULATED GLASS

Clear Safety  
Clear Beveled  
Glue Chip  
Low-E  
Rain  
Reed  
Frosted

### TRIPLE GLAZED

Q - Y

#### "Q" GLASS

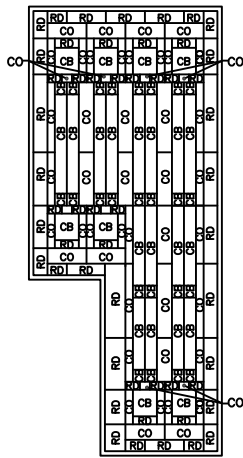

**LEGEND**  
CB-Clear Bevel  
CO-Cotswald  
RD-Reed

#### "Y" GLASS

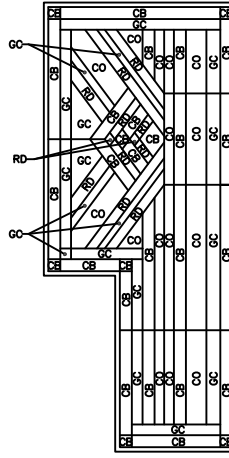

**LEGEND**  
CB-Clear Bevel  
GC-Glue Chip  
CO-Cotswald  
RD-Reed

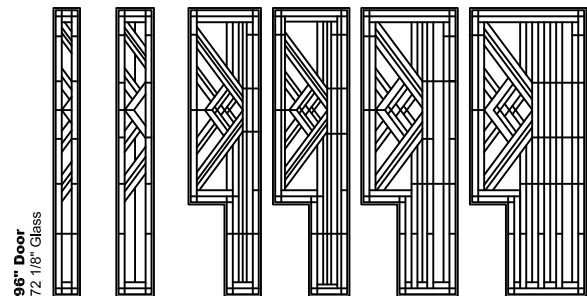
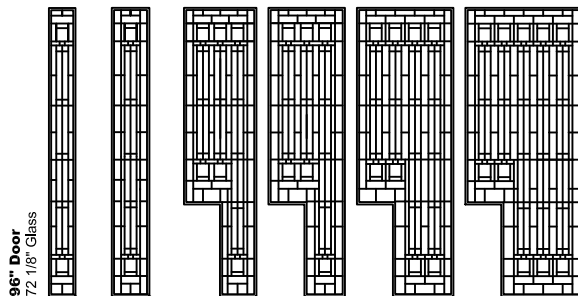
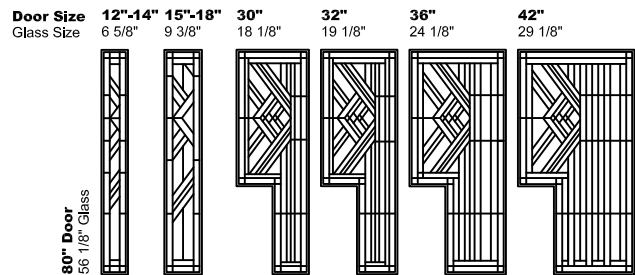
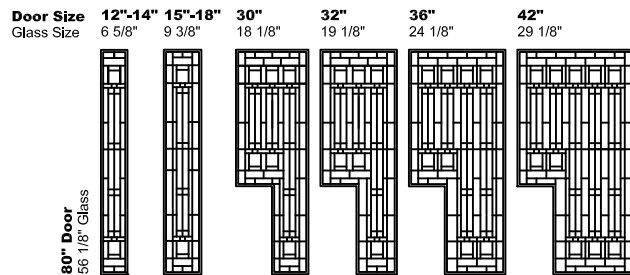

#### INSULATED GLASS

- Clear Safety
- Clear Beveled
- Glue Chip
- Low-E
- Rain
- Reed
- Frosted

#### TRIPLE GLAZED

Q - Y

#### "Q" GLASS

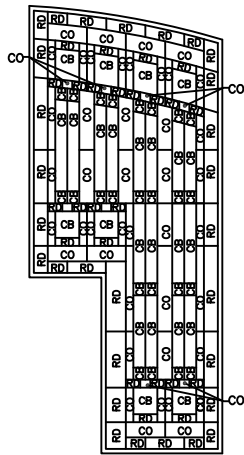

**LEGEND**  
 CB-Clear Bevel  
 CO-Cotswald  
 RD-Reed

#### "Y" GLASS

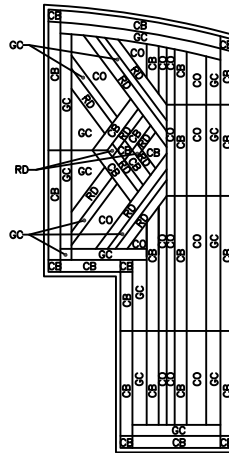

**LEGEND**  
 CB-Clear Bevel  
 GC-Glue Chip  
 CO-Cotswald  
 RD-Reed

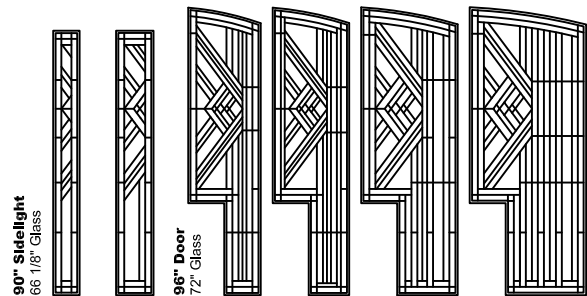
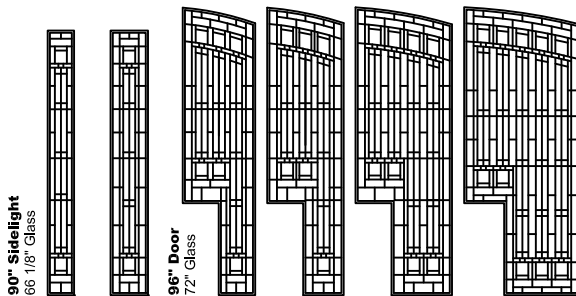
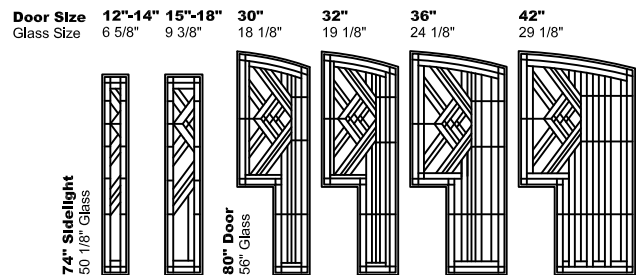
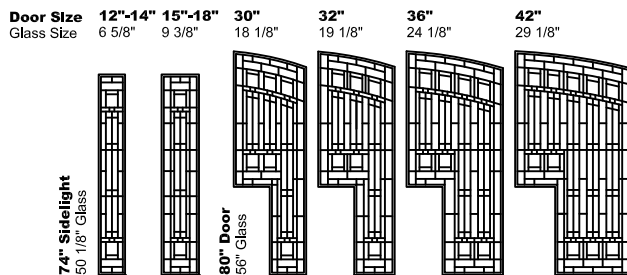

#### INSULATED GLASS

Clear Safety  
 Clear Beveled  
 Glue Chip  
 Low-E  
 Rain  
 Reed  
 Frosted

#### TRIPLE GLAZED

Q - Y

#### "Q" GLASS

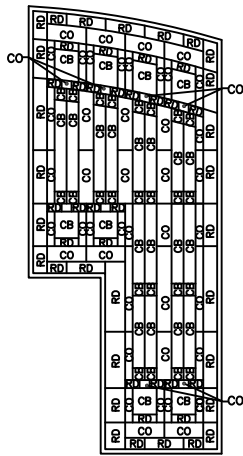

**LEGEND**  
 CB-Clear Bevel  
 CO-Cotswald  
 RD-Reed

#### "Y" GLASS

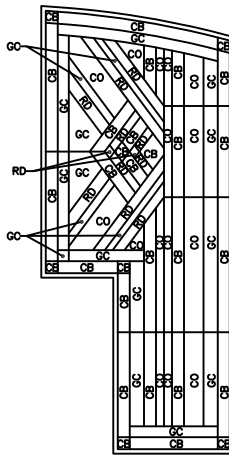

**LEGEND**  
 CB-Clear Bevel  
 GC-Glue Chip  
 CO-Cotswald  
 RD-Reed

**Door Size** 30" 32" 36" 42"  
**Glass Size** 18 1/8" 19 1/8" 24 1/8" 29 1/8"

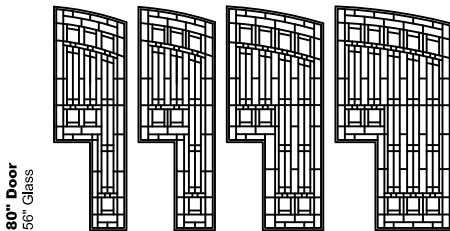

**80" Door**  
 56" Glass

**Door Size** 30" 32" 36" 42"  
**Glass Size** 18 1/8" 19 1/8" 24 1/8" 29 1/8"

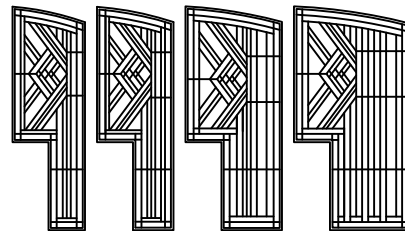

**80" Door**  
 56" Glass

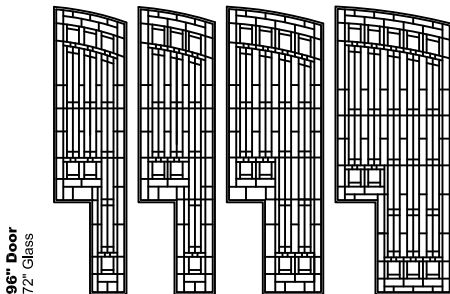

**96" Door**  
 72" Glass

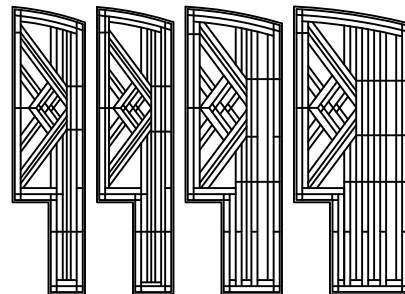

**96" Door**  
 72" Glass

### INSULATED GLASS

Clear Safety  
 Clear Beveled  
 Glue Chip  
 Low-E  
 Rain  
 Reed  
 Frosted

### TRIPLE GLAZED

Q - Y

#### "Q" GLASS

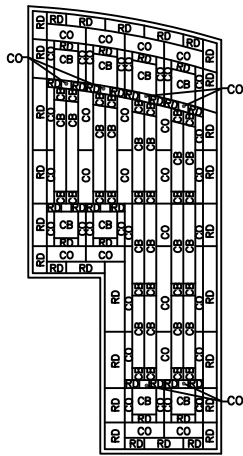

**LEGEND**  
 CB-Clear Bevel  
 CO-Cotswald  
 RD-Reed

#### "Y" GLASS

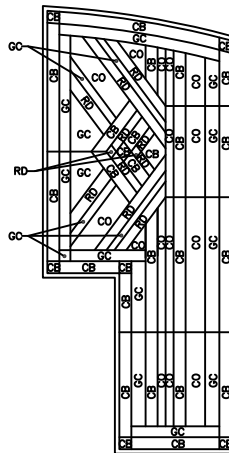

**LEGEND**  
 CB-Clear Bevel  
 GC-Glue Chip  
 CO-Cotswald  
 RD-Reed

**Door Size** 30" 32" 36" 42"  
**Glass Size** 18 1/8" 19 1/8" 24 1/8" 29 1/8"

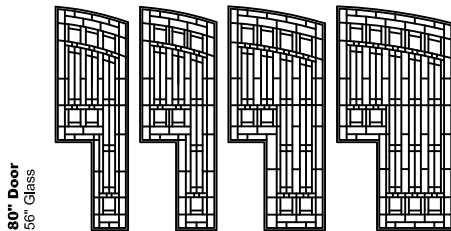

**80" Door**  
 56" Glass

**Door Size** 30" 32" 36" 42"  
**Glass Size** 18 1/8" 19 1/8" 24 1/8" 29 1/8"

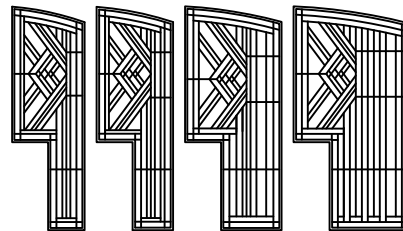

**80" Door**  
 56" Glass

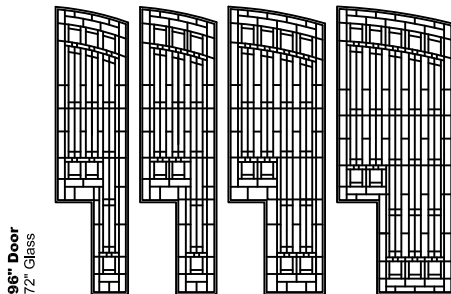

**96" Door**  
 72" Glass

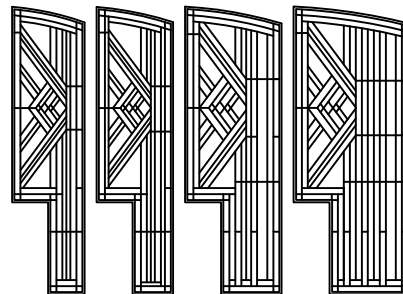

**96" Door**  
 72" Glass

### INSULATED GLASS

Clear Safety	Clear Crystal (Cast Glass)
Clear Beveled	Blue Crystal (Cast Glass)
Glue Chip	Grey Crystal (Cast Glass)
Low-E	
Rain	
Reed	
Frosted	

### TRIPLE GLAZED

A - B - G - K - LG - T - V

#### "A" GLASS

Door Size  
Glass Size

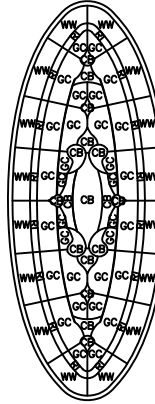

LEGEND  
CB-Clear Bevel  
GC-Glue Chip  
WW-Clear Water  
RI-Ripple

12"-15"  
7 7/8"



16"-18" 36"/42"  
8 3/8" 19 7/8"



#### "B" GLASS

Door Size  
Glass Size

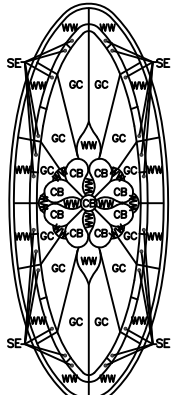

LEGEND  
CB-Clear Bevel  
GC-Glue Chip  
WW-Clear Water  
SE-Seedy

12"-15"  
7 7/8"

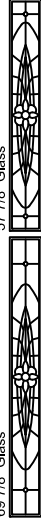

16"-18" 36"/42"  
8 3/8" 19 7/8"



#### "G" GLASS

Door Size  
Glass Size

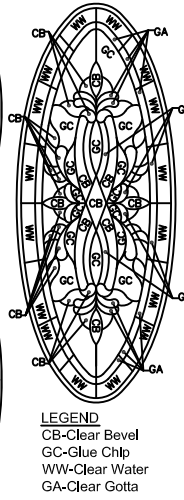

LEGEND  
CB-Clear Bevel  
GC-Glue Chip  
WW-Clear Water  
GA-Clear Gotta

12"-15"  
7 7/8"



16"-18" 36"/42"  
8 3/8" 19 7/8"



#### "K" GLASS

Door Size  
Glass Size

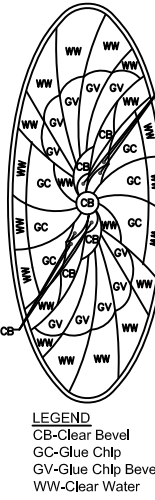

LEGEND  
CB-Clear Bevel  
GC-Glue Chip  
GV-Glue Chip Bevel  
WW-Clear Water

12"-15"  
7 7/8"



16"-18" 36"/42"  
8 3/8" 19 7/8"

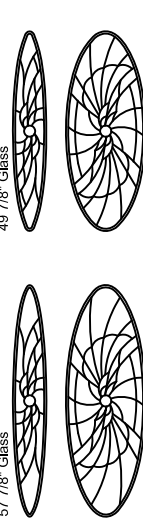

#### "LG" GLASS

Door Size  
Glass Size

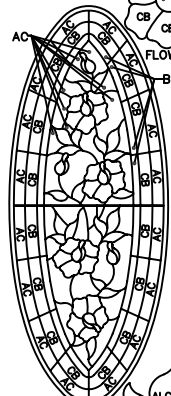

LEGEND  
CB-Clear Bevel  
AC-Clear Antique  
BW-Antique Brown  
ALR-Ant. Light Rose  
ALG-Ant. Light Green

12"-15"  
7 7/8"



16"-18" 36"/42"  
8 3/8" 19 7/8"



#### "T" GLASS

Door Size  
Glass Size

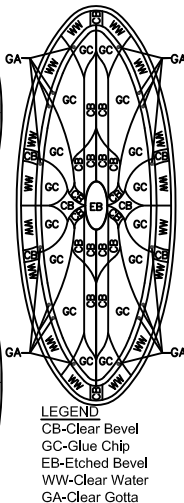

LEGEND  
CB-Clear Bevel  
GC-Glue Chip  
EB-Etched Bevel  
WW-Clear Water  
GA-Clear Gotta

12"-15"  
7 7/8"



16"-18" 36"/42"  
8 3/8" 19 7/8"



#### "V" GLASS

Door Size  
Glass Size

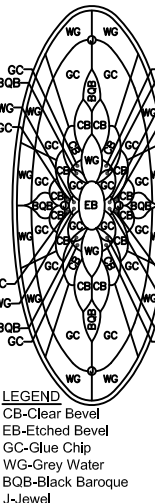

LEGEND  
CB-Clear Bevel  
EB-Etched Bevel  
GC-Glue Chip  
WG-Grey Water  
BOB-Black Baroque  
J-Jewel

12"-15"  
7 7/8"



16"-18" 36"/42"  
8 3/8" 19 7/8"

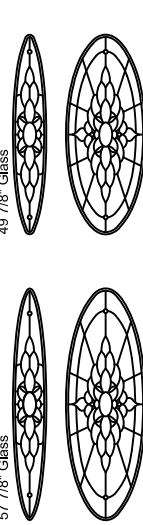



GRILLE NOTES

---

Finish: Dark Patina  
Material: Aluminum

- Door & Sidelight Grilles are Operable  
(Handed to Match Door)
- Design may Vary by Size/Shape of Door  
(18"/36" x 96" Shown)
- Grilles May be Customized

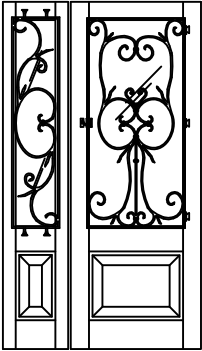

FLORENCE

Surface Mounted to Stiles  
Sidelight Grille is Non-Operable  
Rust Patina Finish Available

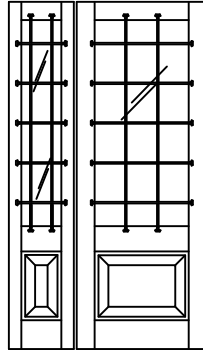

RUSTIC

Surface Mounted to Stiles  
Grilles are Non-Operable  
Rust Patina Finish Available

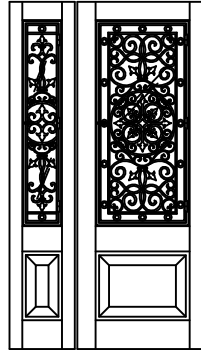

ARMADA

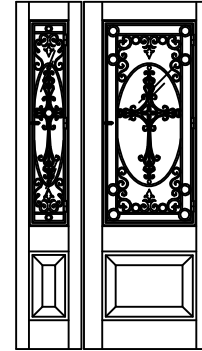

CATHEDRAL

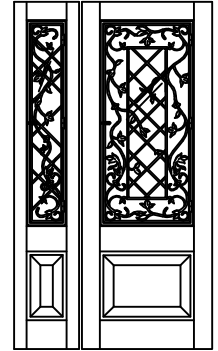

CHATEAU

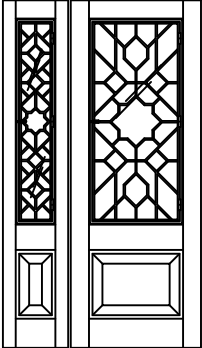

ETRUSCAN

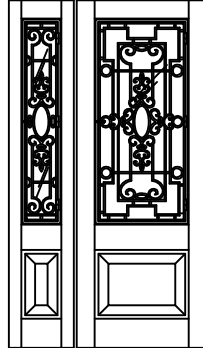

GEORGIAN

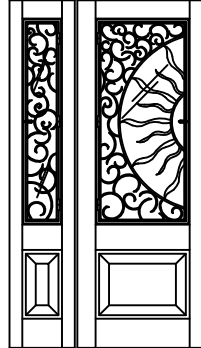

HELIOS

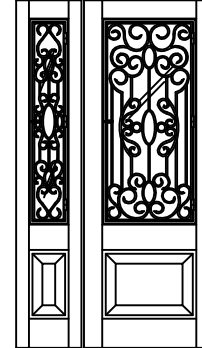

HERITAGE

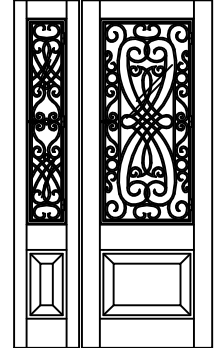

INFINITY

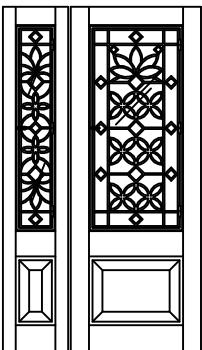

LOTUS

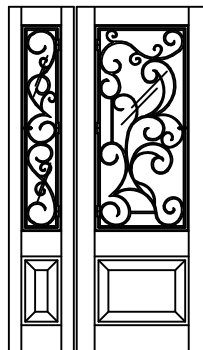

MEDITERRANEAN

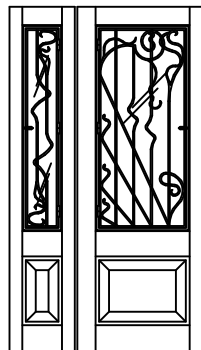

NOUVEAU

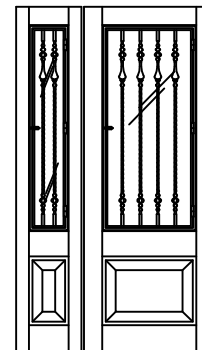

REGAL

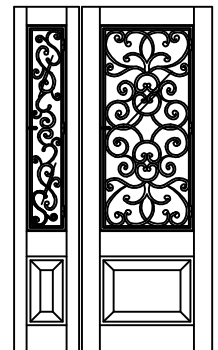

VERSAILLES

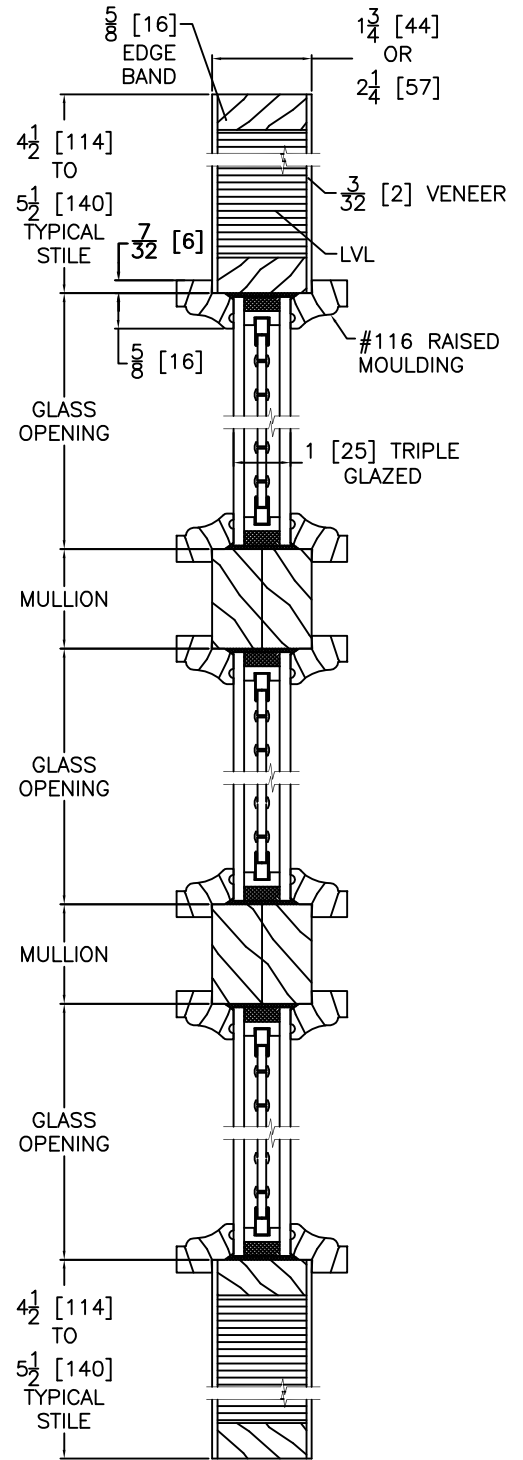
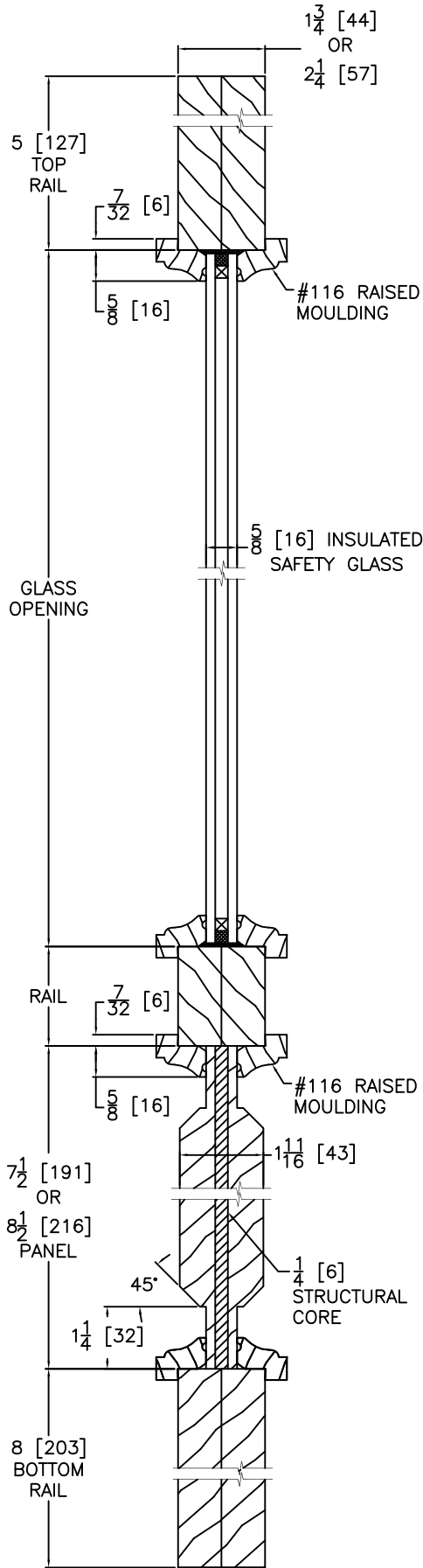
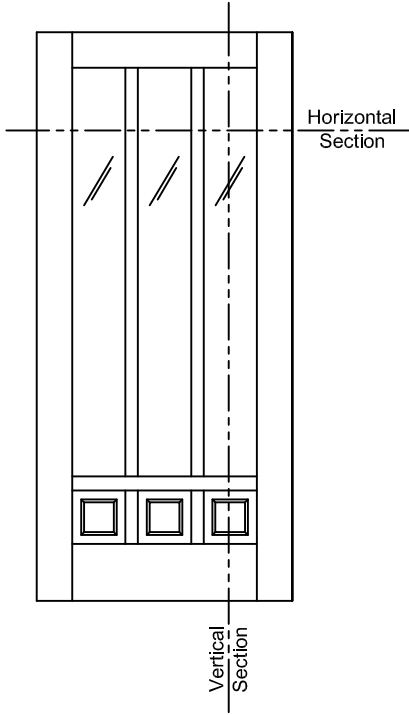

HORIZONTAL DOOR CROSS SECTION

Triple Glazed  
Engineered Stile Option  
(Upon Request or Doors > 3'-6" X 8'-0")

VERTICAL DOOR/SIDELIGHT CROSS SECTION  
Insulated Glass

**Notes:**  
Stile, Rail, Panel & Glass  
vary by Size & Model of Door.  
Typical Sizes are Shown.

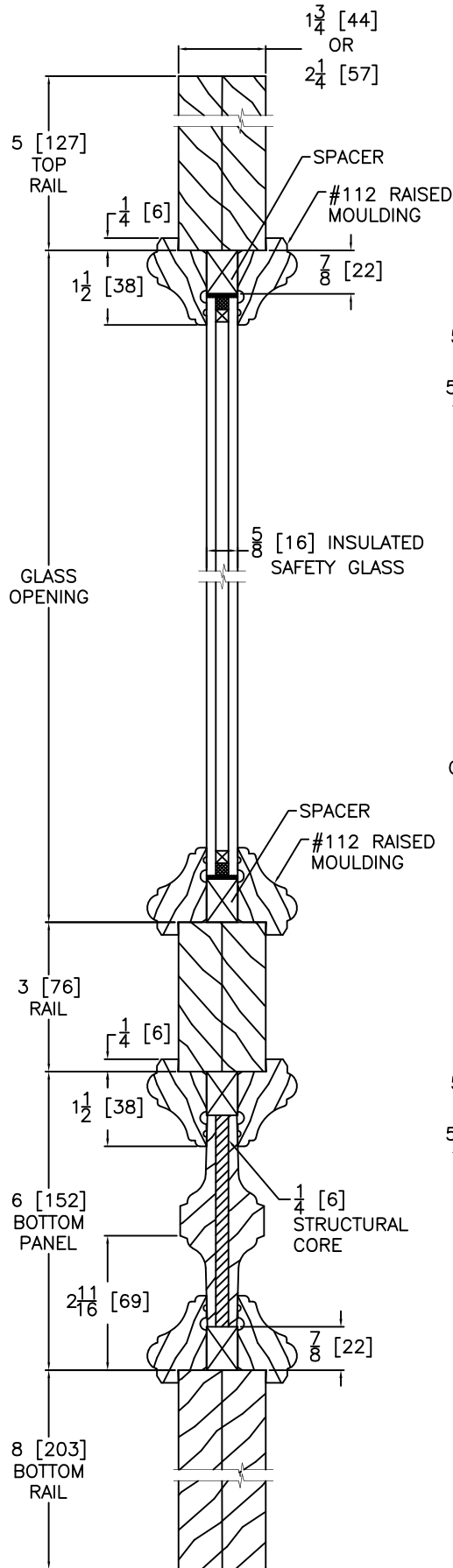
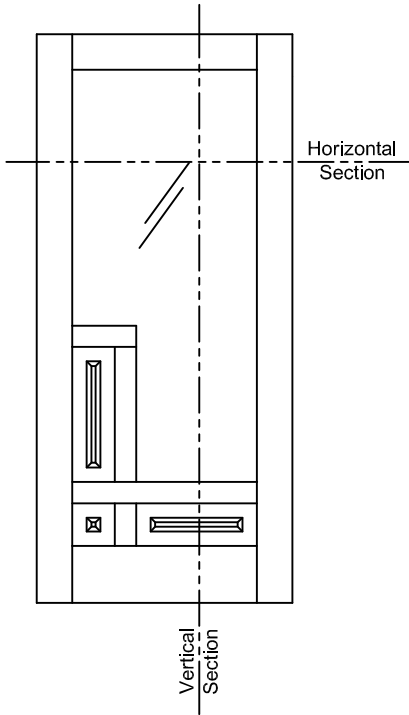

VERTICAL DOOR/SIDELIGHT CROSS SECTION  
Insulated Glass

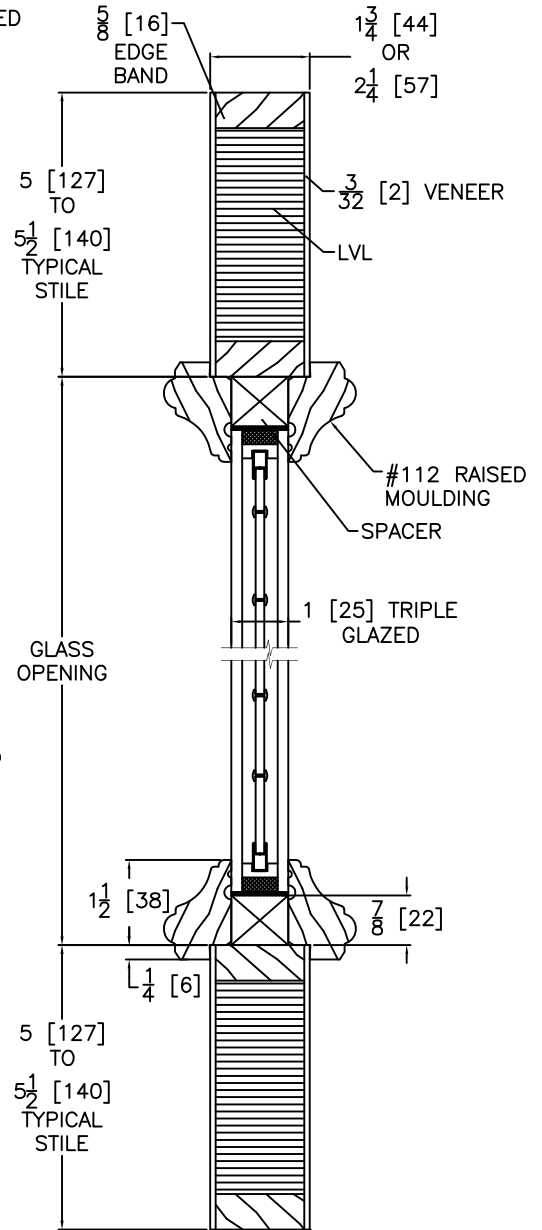

HORIZONTAL DOOR CROSS SECTION  
Triple Glazed  
Engineered Stile Option  
(Upon Request or Doors > 3'-6" X 8'-0")

**Notes:**  
Stile, Rail, Panel & Glass  
vary by Size & Model of Door.  
Typical Sizes are Shown.

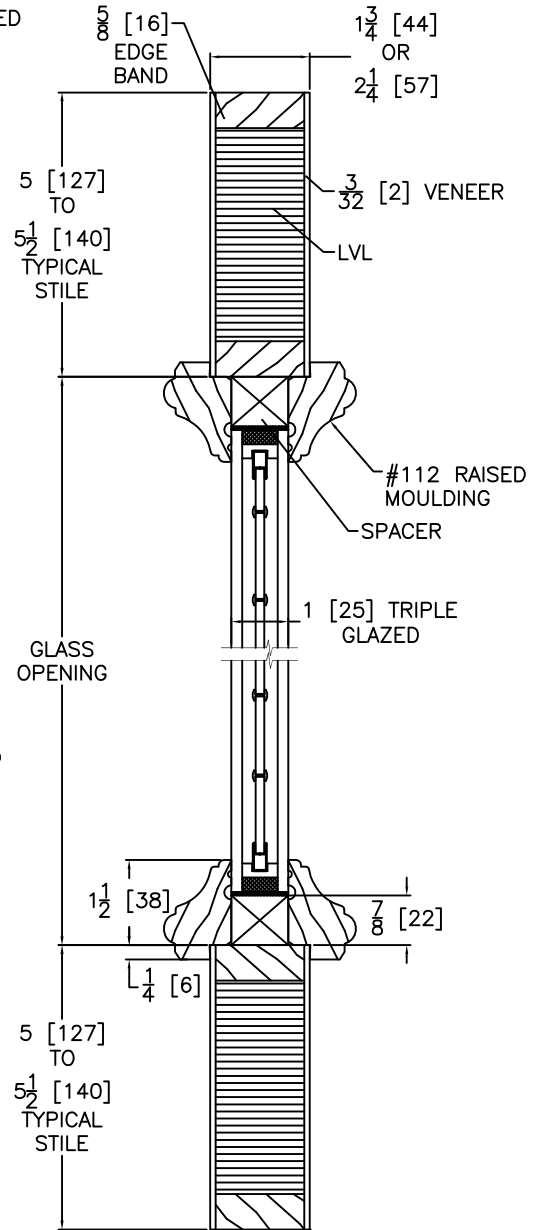
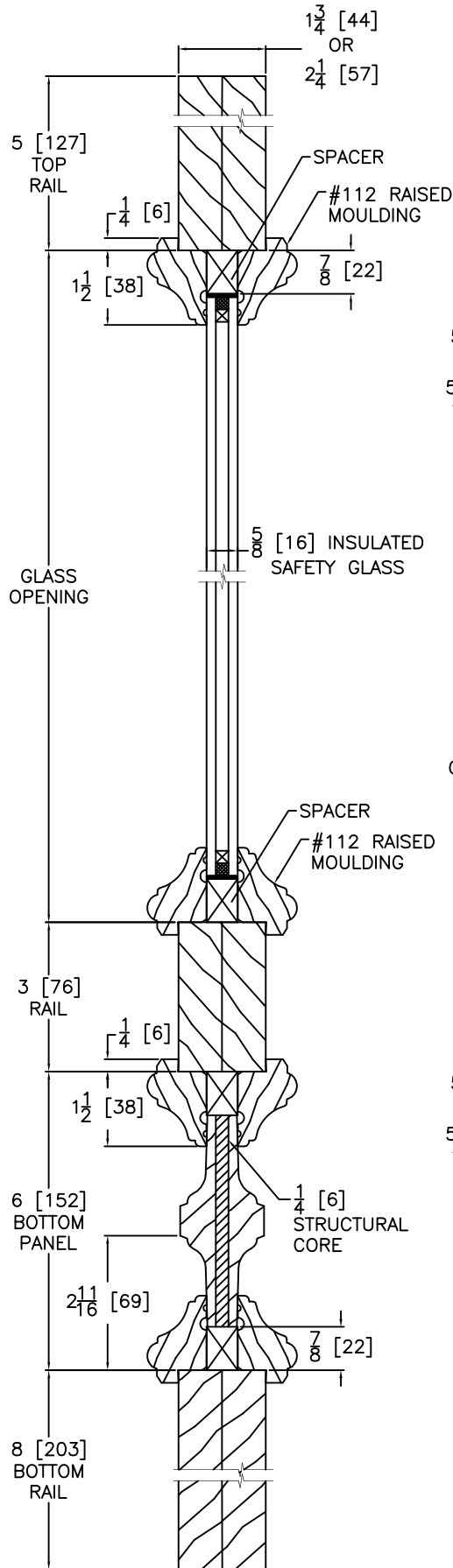
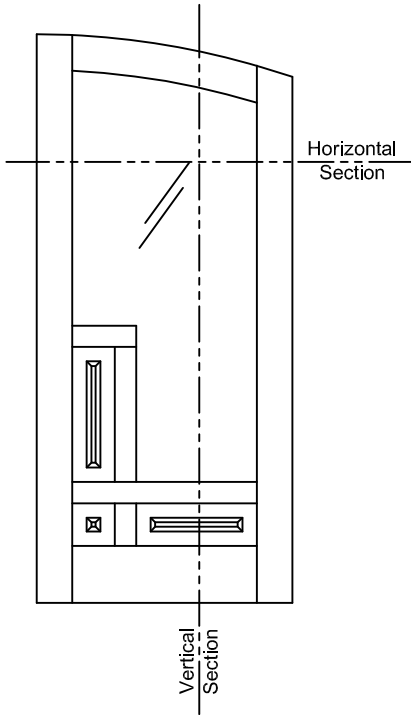

**HORIZONTAL DOOR CROSS SECTION**  
Triple Glazed  
Engineered Stile Option  
(Upon Request or Doors > 3'-6" X 8'-0")

**VERTICAL DOOR/SIDELIGHT CROSS SECTION**  
Insulated Glass

**Notes:**  
Stile, Rail, Panel & Glass  
vary by Size & Model of Door.  
Typical Sizes are Shown.

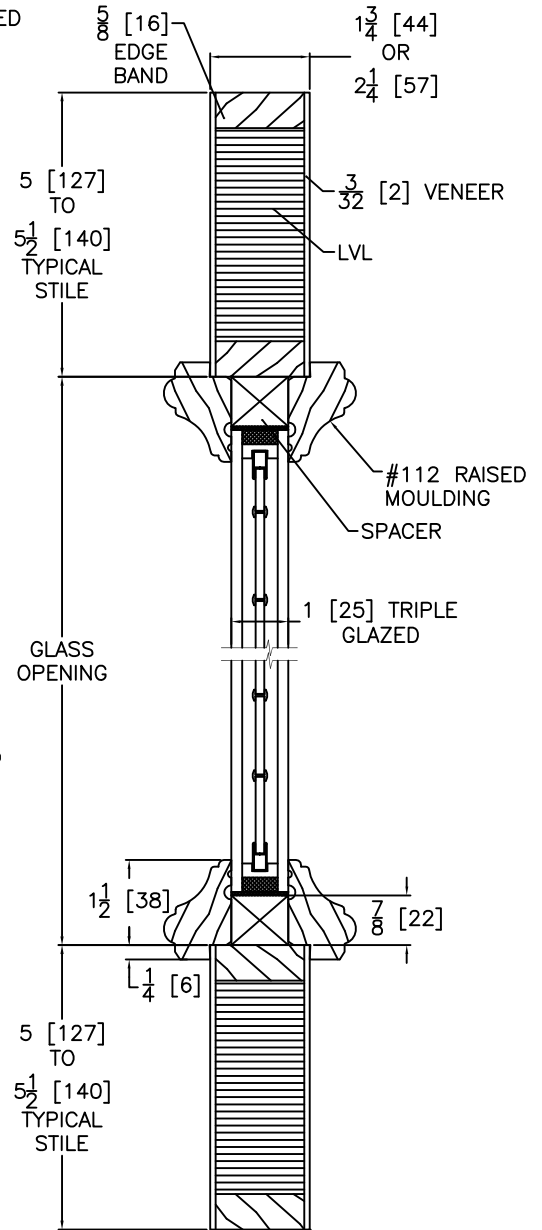
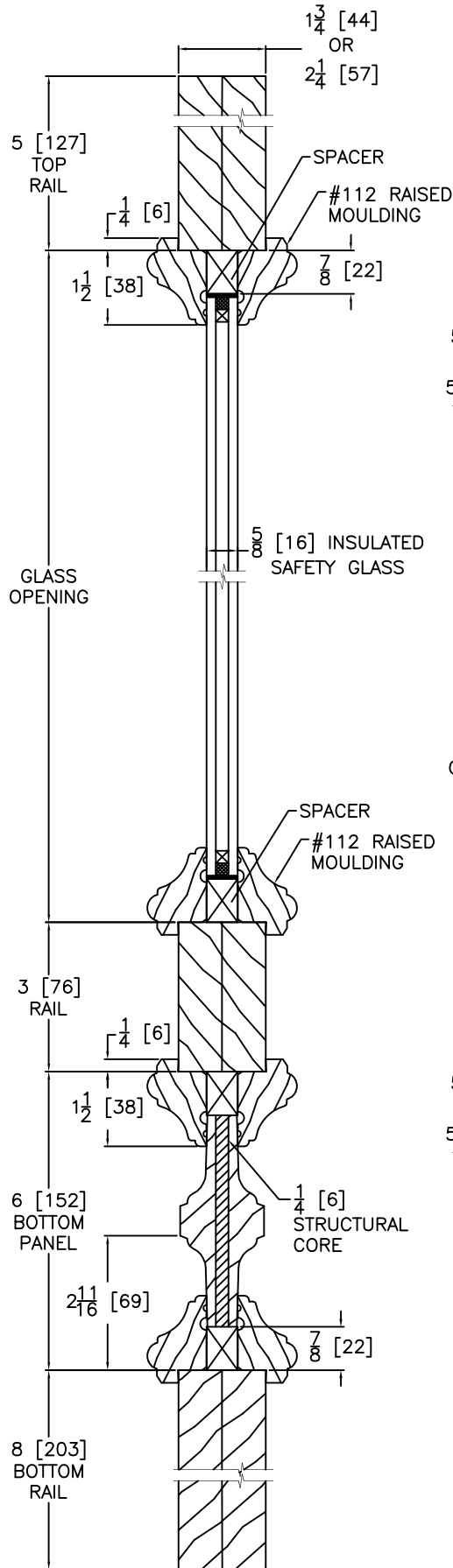
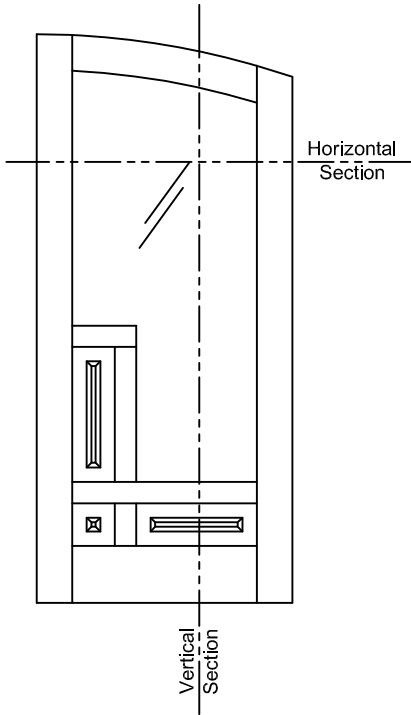

**HORIZONTAL DOOR CROSS SECTION**  
Triple Glazed  
Engineered Stile Option  
(Upon Request or Doors > 3'-6" X 8'-0")

**VERTICAL DOOR/SIDELIGHT CROSS SECTION**  
Insulated Glass

**Notes:**  
Stile, Rail, Panel & Glass  
vary by Size & Model of Door.  
Typical Sizes are Shown.

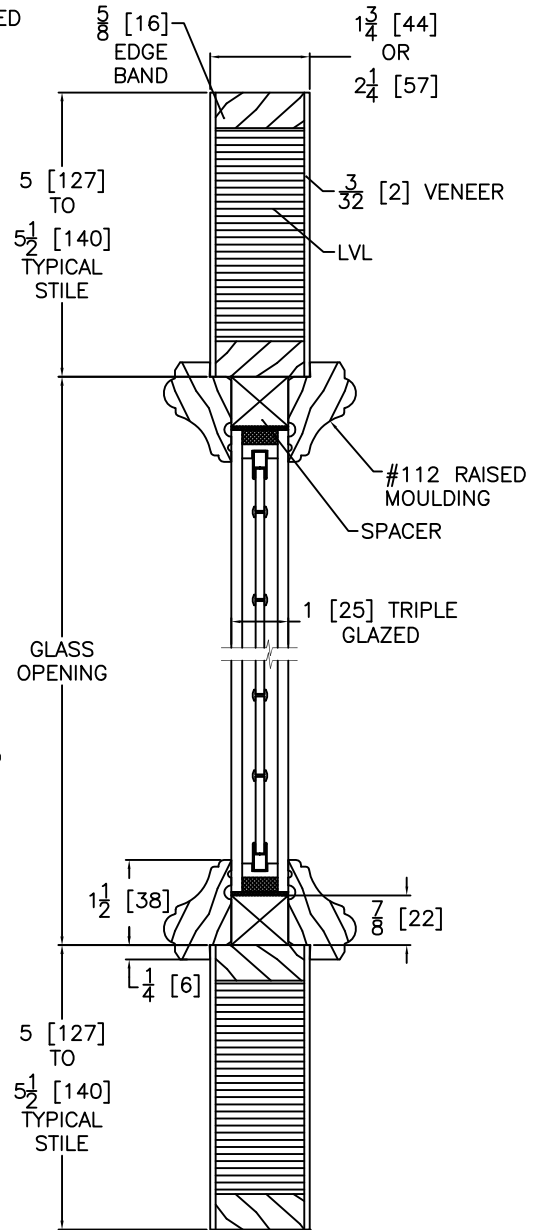
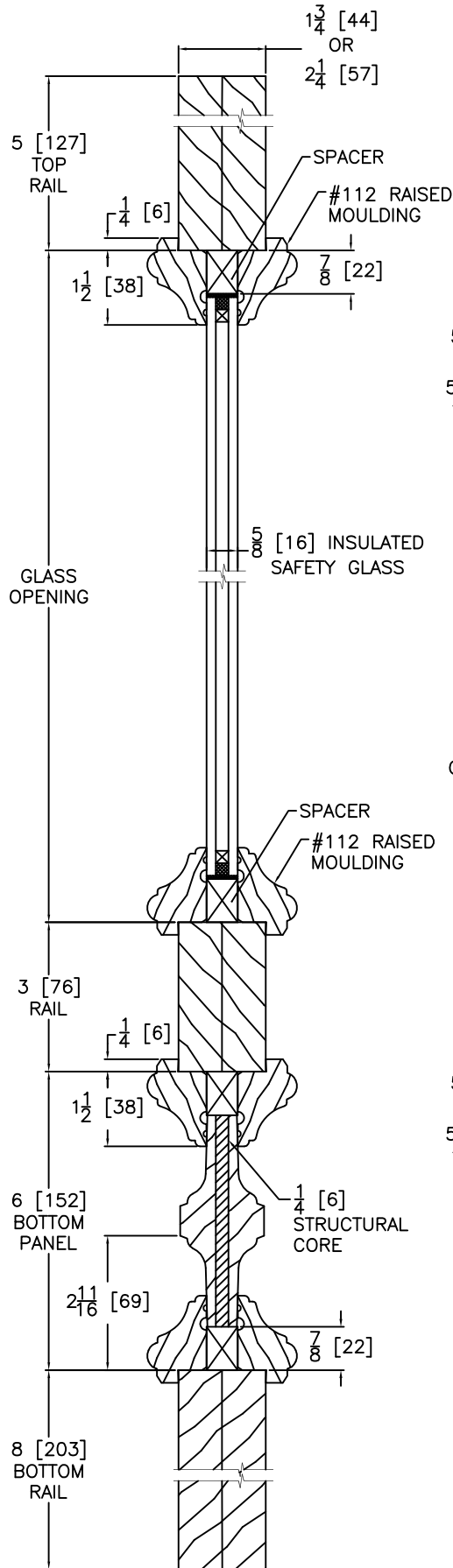
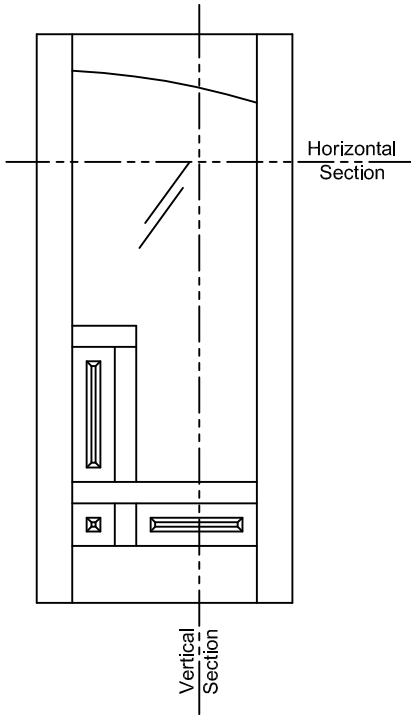

**HORIZONTAL DOOR CROSS SECTION**  
Triple Glazed  
Engineered Stile Option  
(Upon Request or Doors > 3'-6" X 8'-0")

**VERTICAL DOOR/SIDELIGHT CROSS SECTION**  
Insulated Glass

**Notes:**  
Stile, Rail, Panel & Glass  
vary by Size & Model of Door.  
Typical Sizes are Shown.

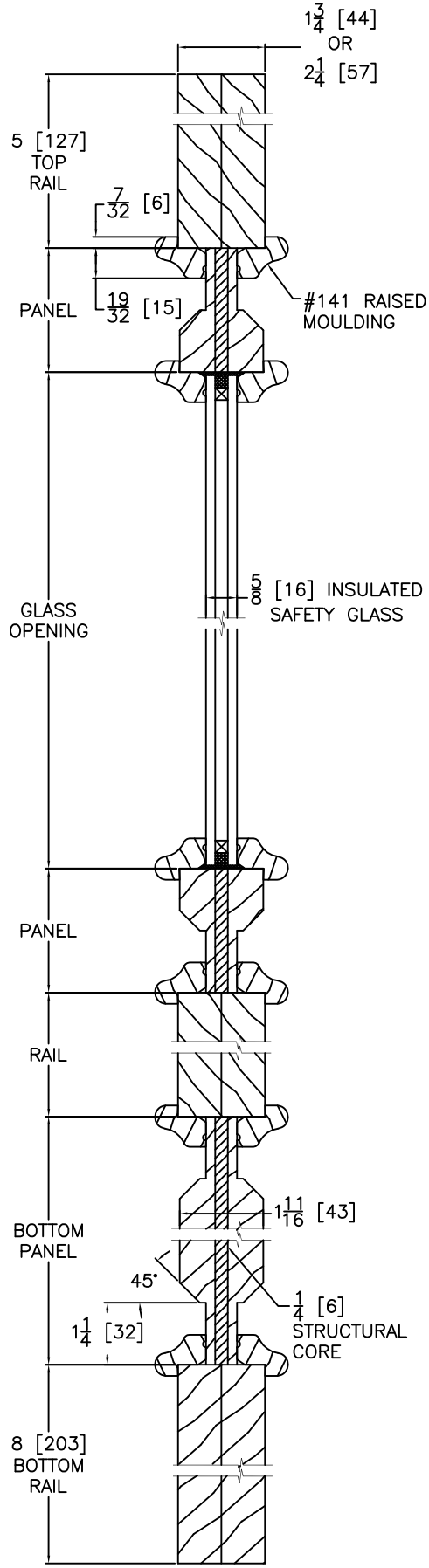
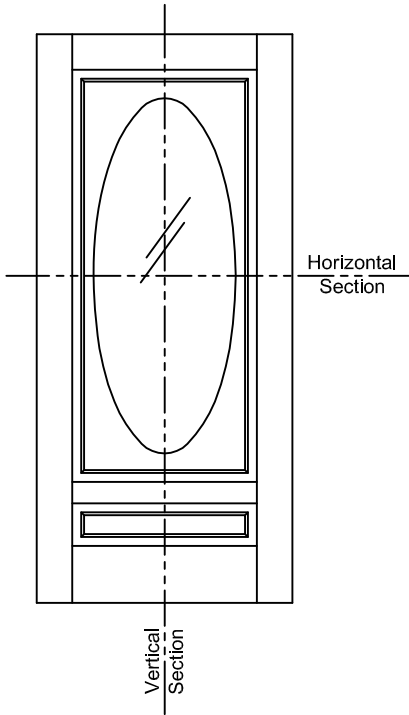

VERTICAL DOOR CROSS SECTION  
Insulated Glass

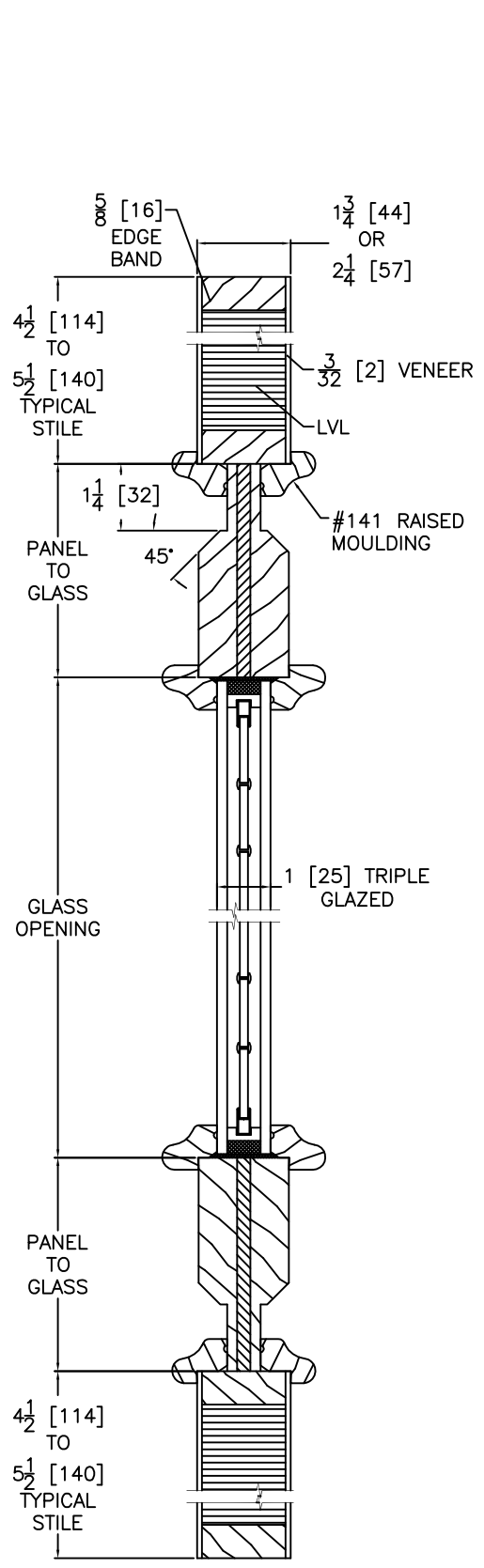

HORIZONTAL DOOR CROSS SECTION  
Triple Glazed  
Engineered Stile Option  
(Upon Request or Doors > 3'-6" X 8'-0")

**Notes:**  
Stile, Rail, Panel & Glass  
vary by Size & Model of Door.  
Typical Sizes are Shown.

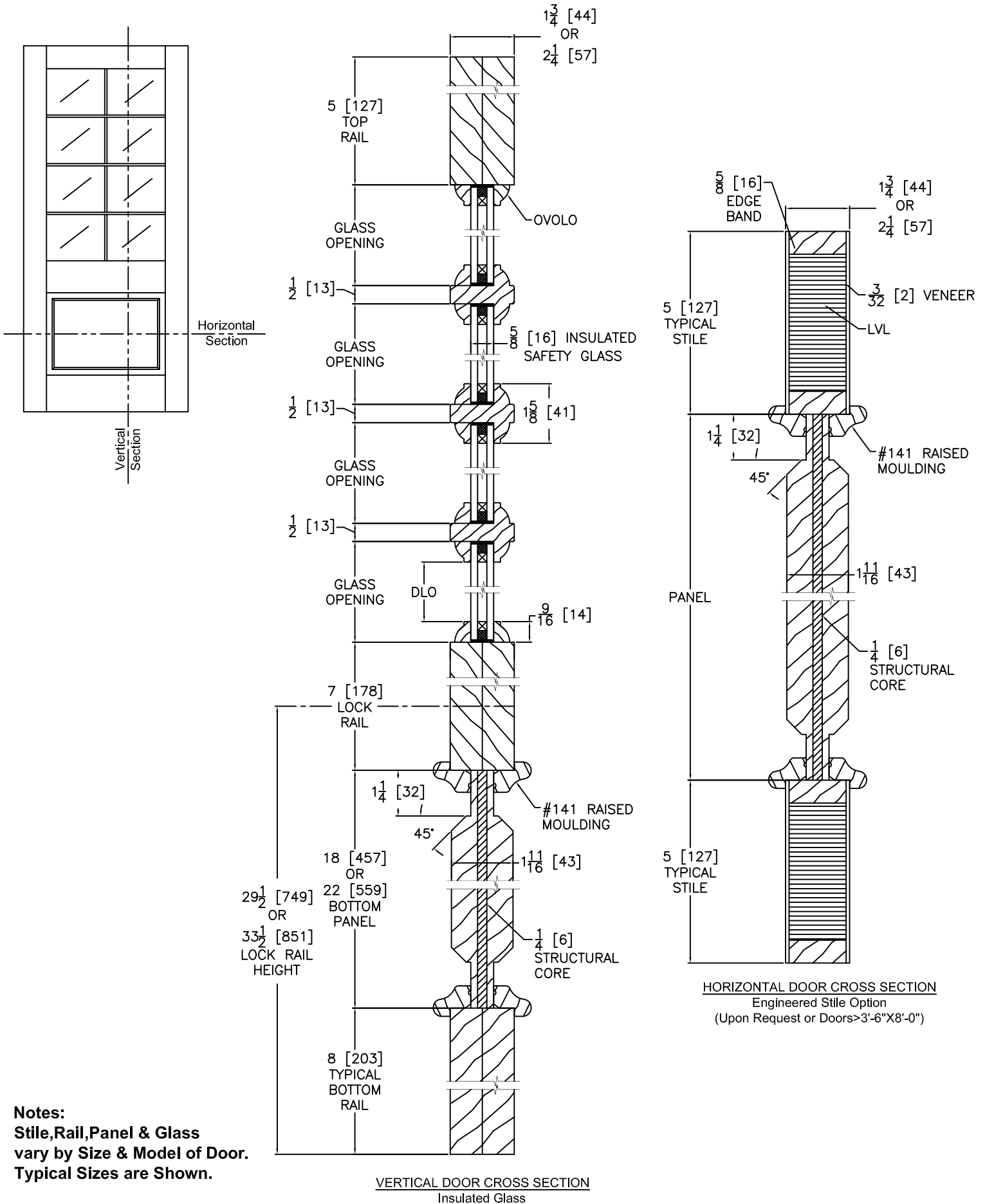



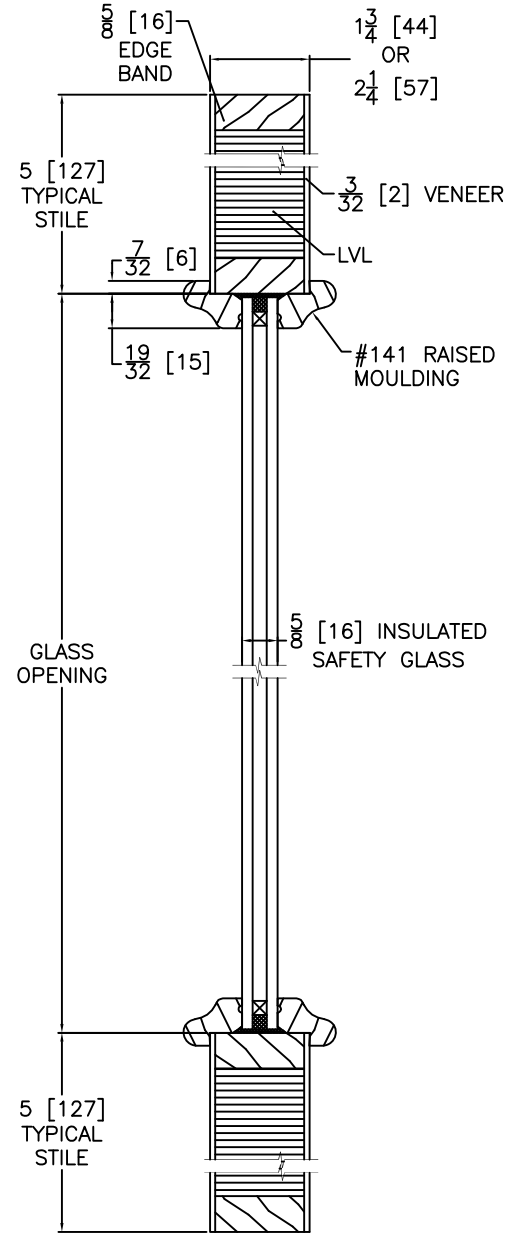
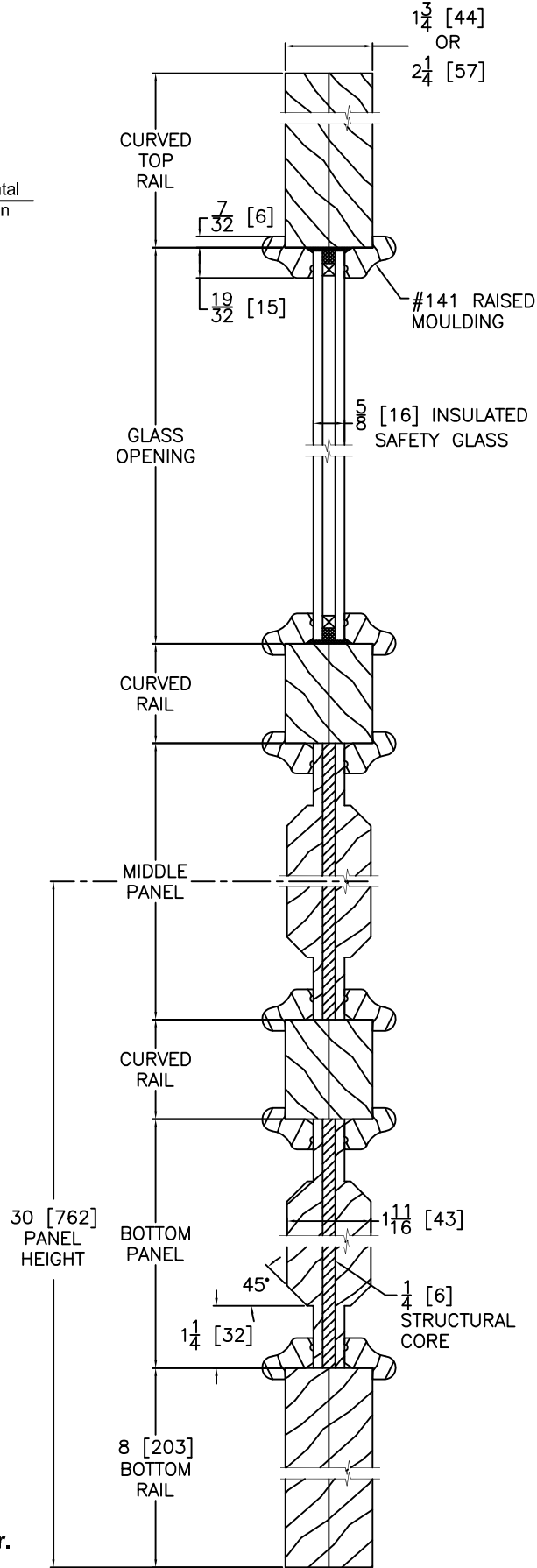
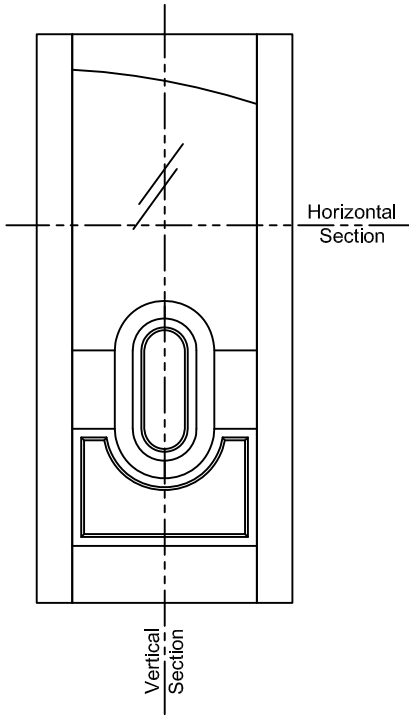

HORIZONTAL DOOR CROSS SECTION  
Insulated Glass  
Engineered Stile Option  
(Upon Request or Doors > 3'-6" X 8'-0")

VERTICAL DOOR CROSS SECTION  
Insulated Glass

**Notes:**  
Stile, Rail, Panel & Glass  
vary by Size & Model of Door.  
Typical Sizes are Shown.

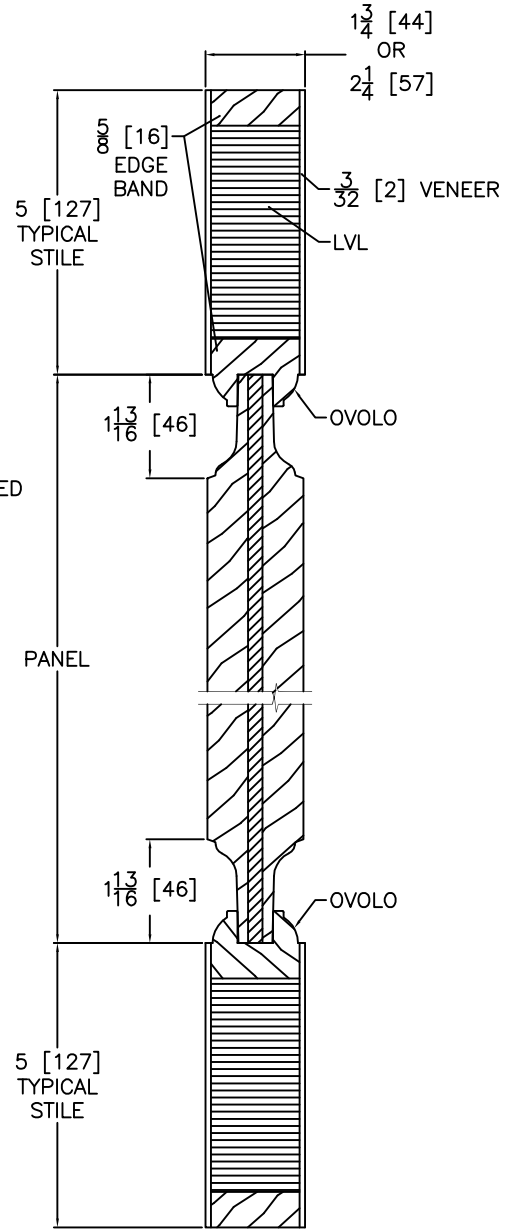
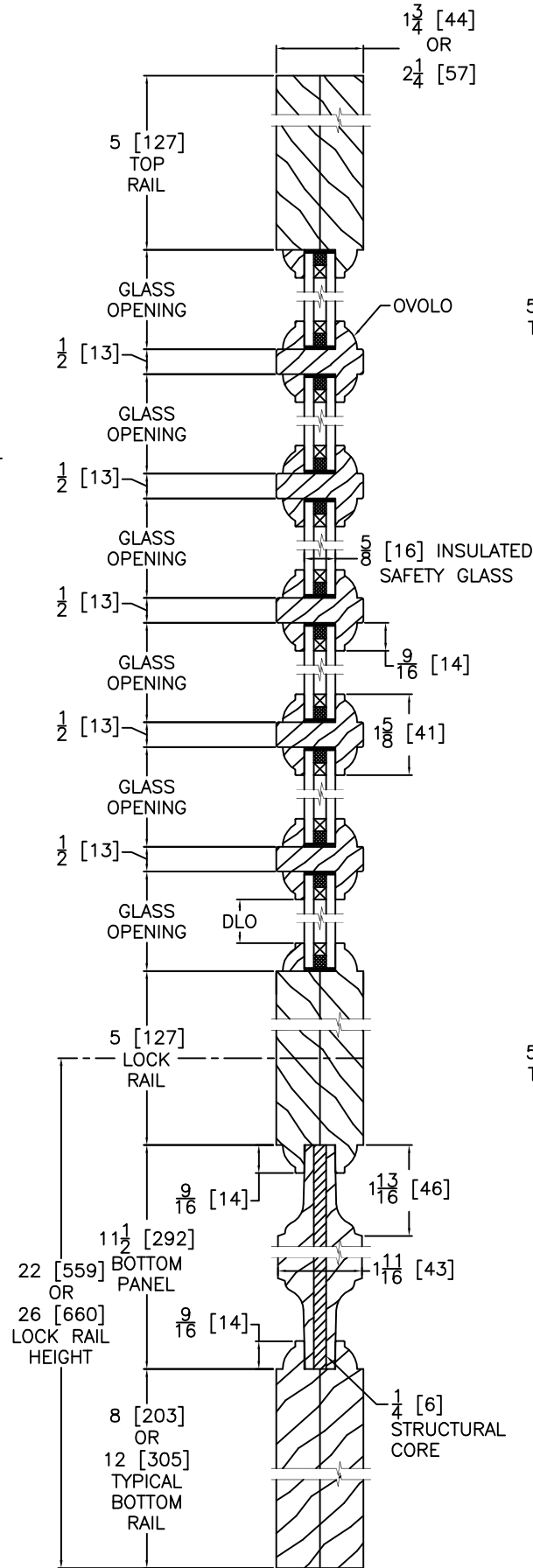
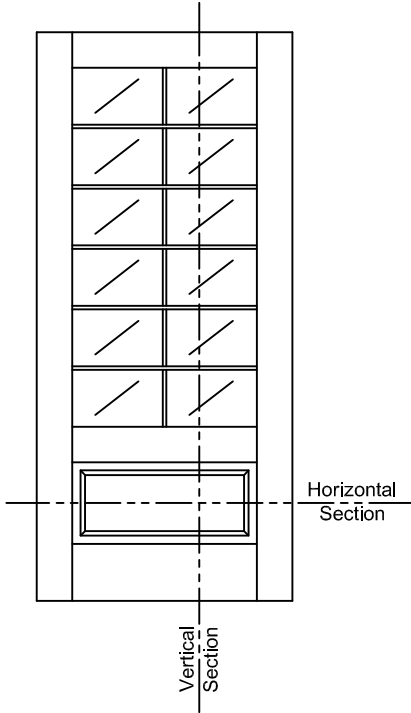

HORIZONTAL DOOR CROSS SECTION  
Engineered Stile Option  
(Upon Request or Doors > 3'-6" X 8'-0")

VERTICAL DOOR/SIDLIGHT CROSS SECTION  
Insulated Glass

**Notes:**  
Stile, Rail, Panel & Glass  
vary by Size & Model of Door.  
Typical Sizes are Shown.

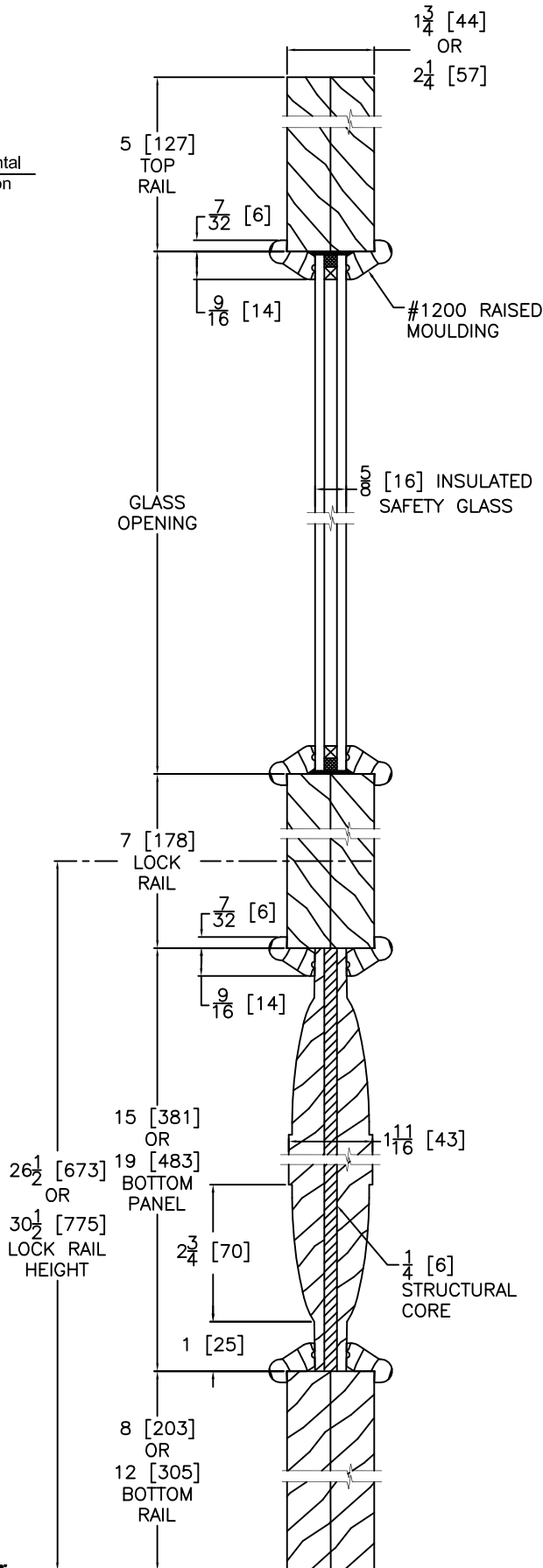
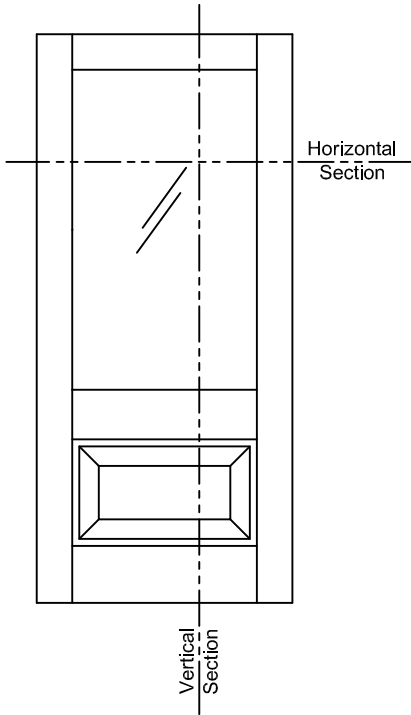

VERTICAL DOOR/SIDELIGHT CROSS SECTION  
Insulated Glass

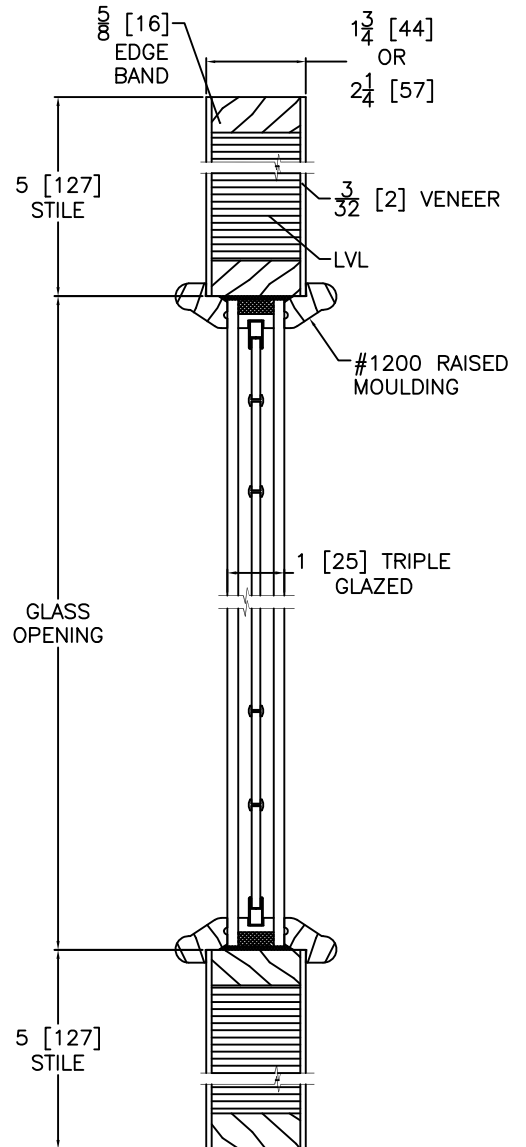
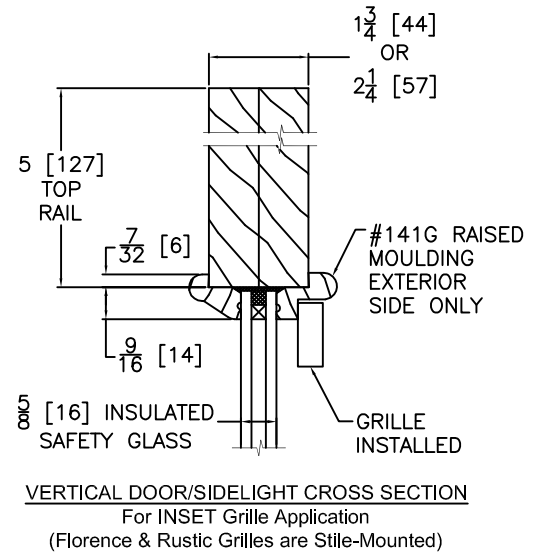

HORIZONTAL DOOR CROSS SECTION  
Triple Glazed  
Engineered Stile Option  
(Upon Request or Doors > 3'-6" X 8'-0")

**Notes:**  
Stile, Rail, Panel & Glass  
vary by Size & Model of Door.  
Typical Sizes are Shown.

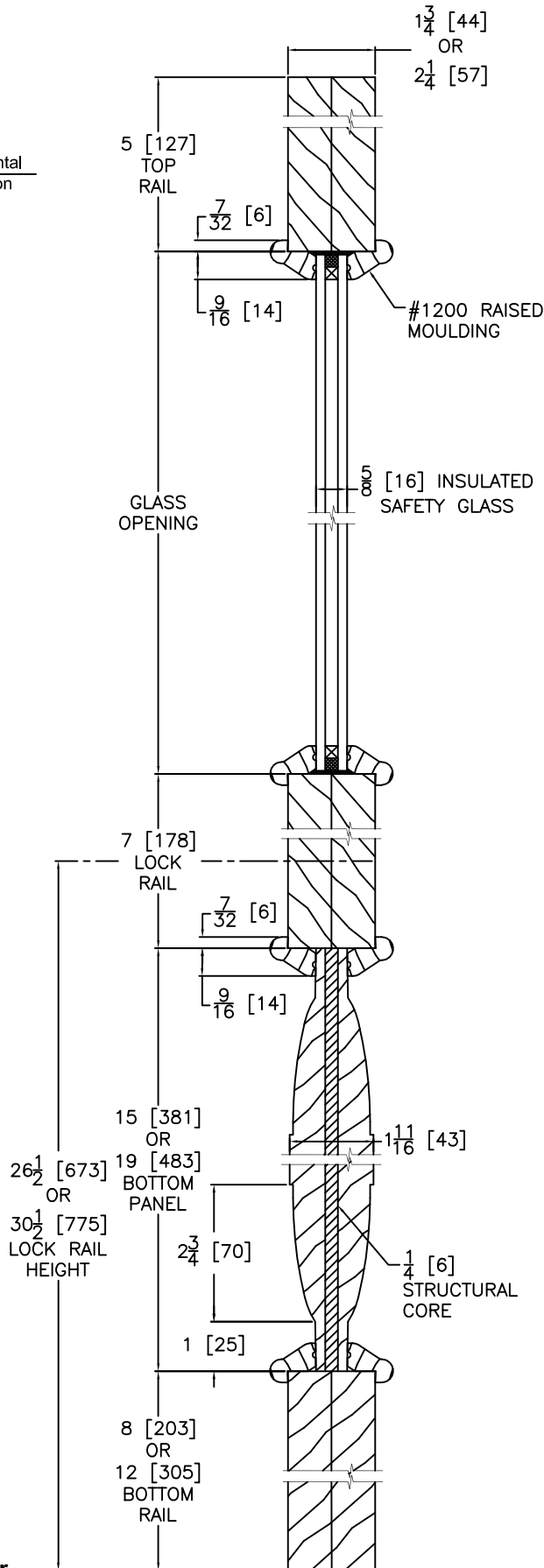
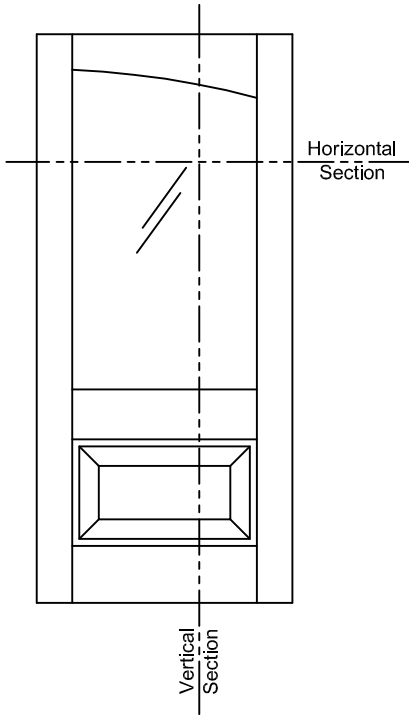

VERTICAL DOOR/SIDELIGHT CROSS SECTION  
Insulated Glass

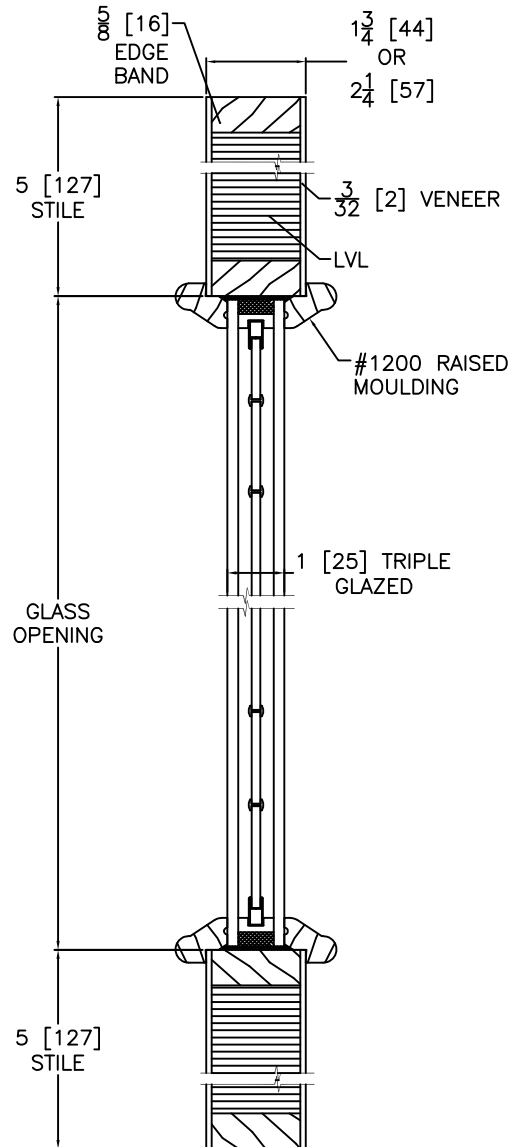
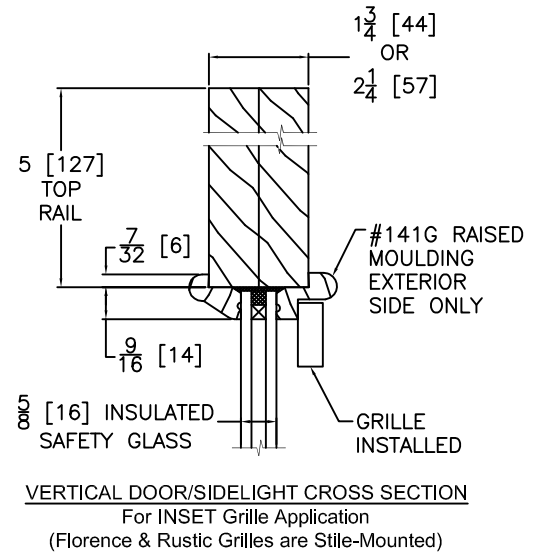

HORIZONTAL DOOR CROSS SECTION  
Triple Glazed  
Engineered Stile Option  
(Upon Request or Doors > 3'-6" X 8'-0")

**Notes:**  
Stile, Rail, Panel & Glass  
vary by Size & Model of Door.  
Typical Sizes are Shown.

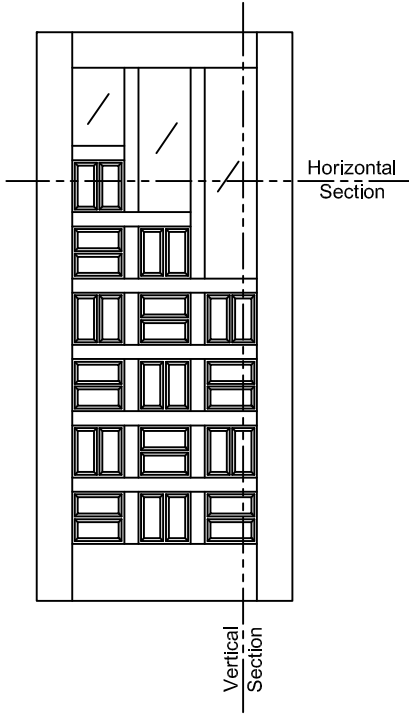

**V-GROOVE/PLANK DETAILS**

Panel Quantity & Plank Widths Vary by Door Size

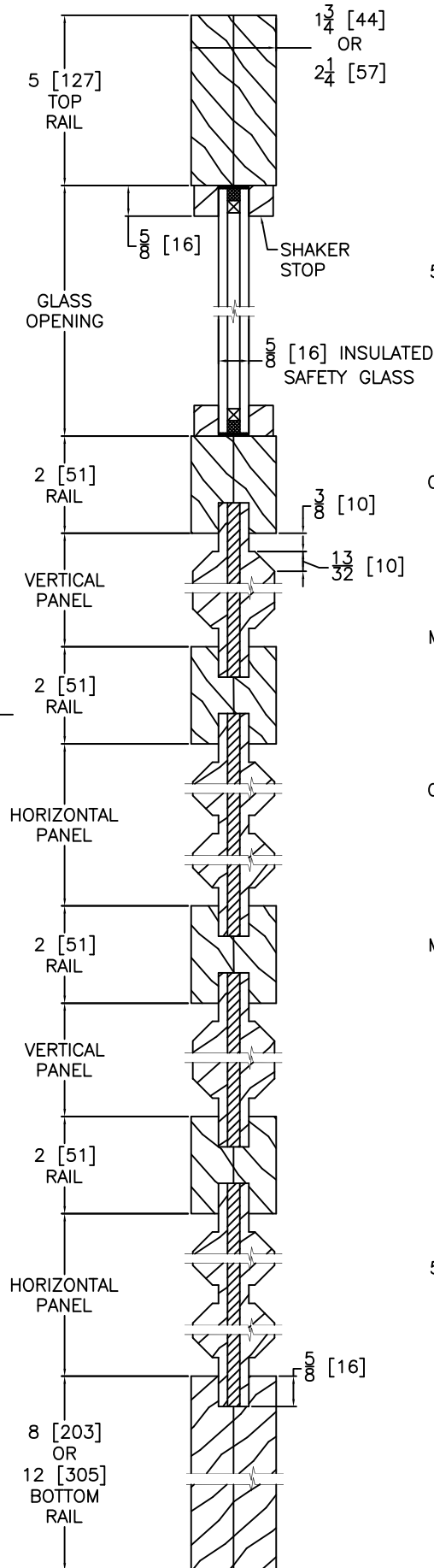

**VERTICAL DOOR CROSS SECTION**  
Insulated Glass

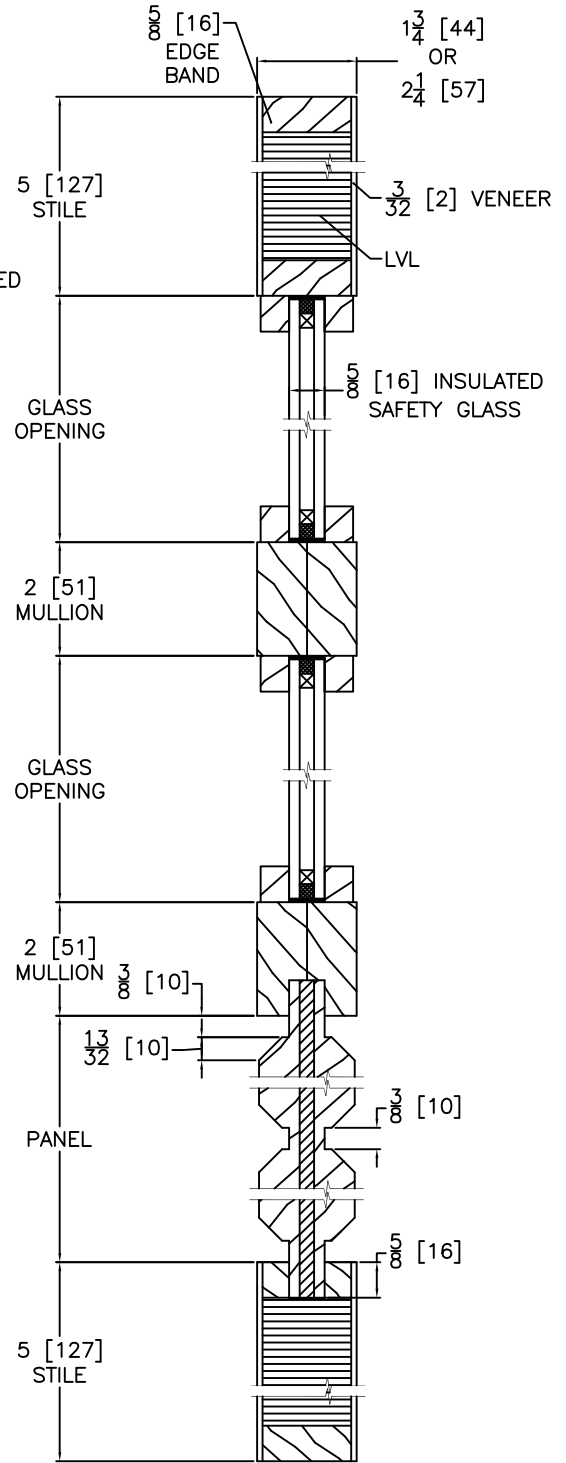

**HORIZONTAL DOOR CROSS SECTION**  
Insulated Glass  
Engineered Stile Option  
(Upon Request or Doors > 3'-6" X 8'-0")

**Notes:**  
Stile, Rail, Panel & Glass  
vary by Size & Model of Door.  
Typical Sizes are Shown.

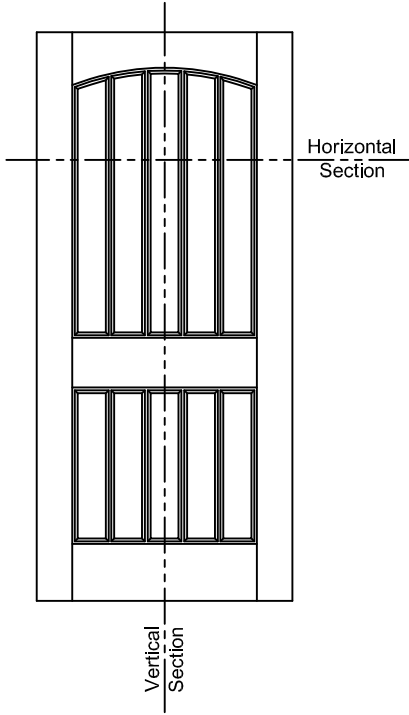

### V-GROOVE/PLANK DETAILS

- 2-6 Door = 4 Planks, 3 23/32" Flat Area Width
- 2-8 Door = 4 Planks, 4 7/32" Flat Area Width
- 3-0 Door = 5 Planks, 3 15/16" Flat Area Width
- 3-6 Door = 6 Planks, 4 3/32" Flat Area Width

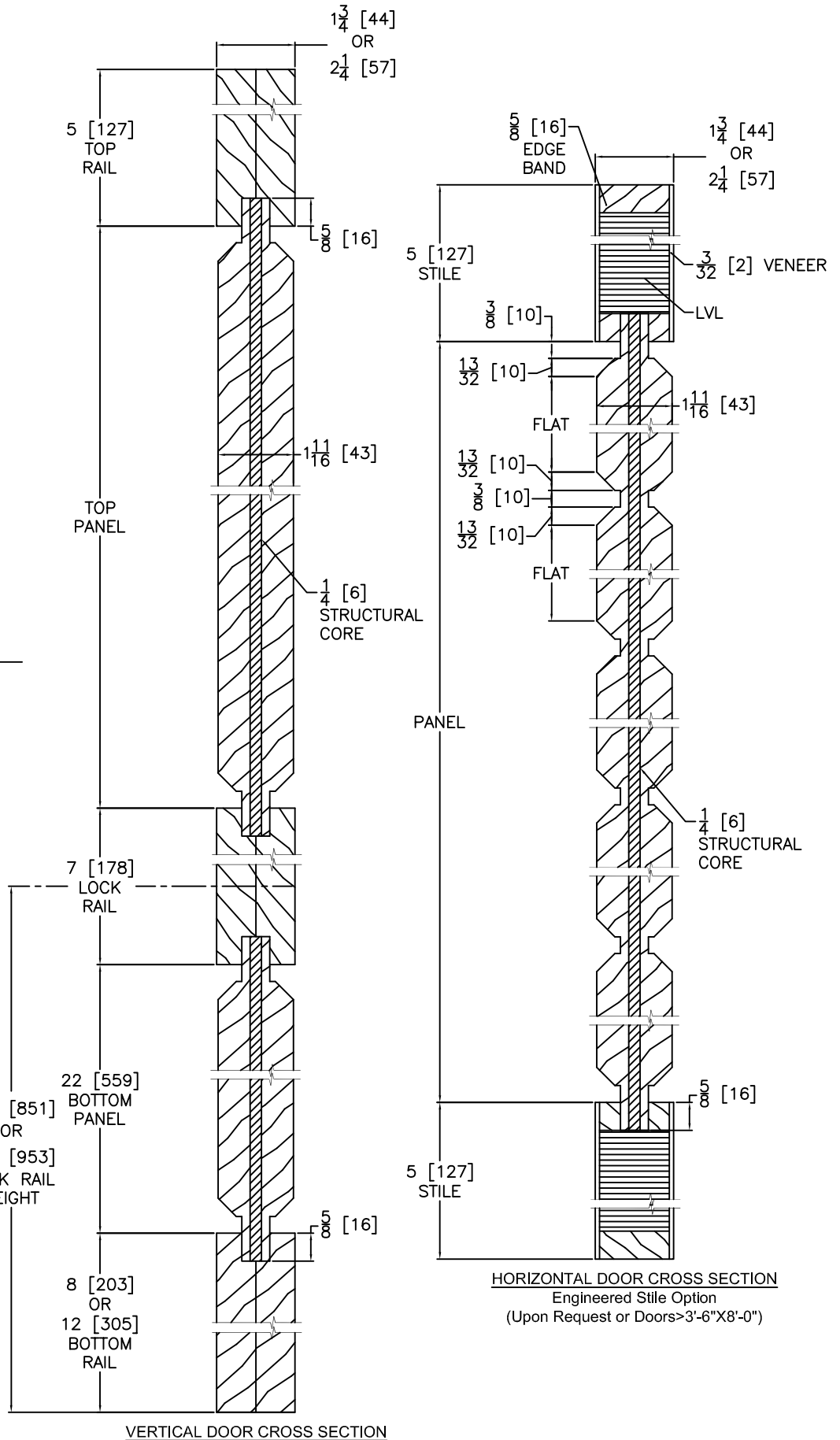
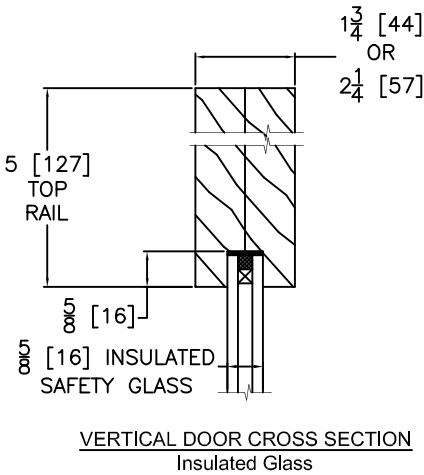

**Notes:**  
Stile, Rail, Panel & Glass  
vary by Size & Model of Door.  
Typical Sizes are Shown.

VERTICAL DOOR CROSS SECTION

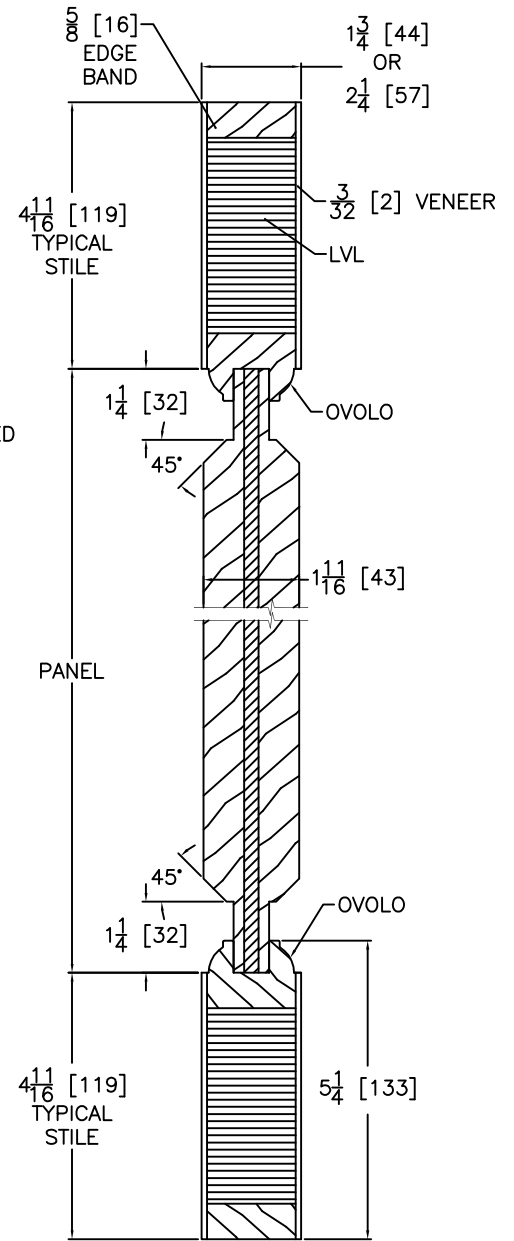
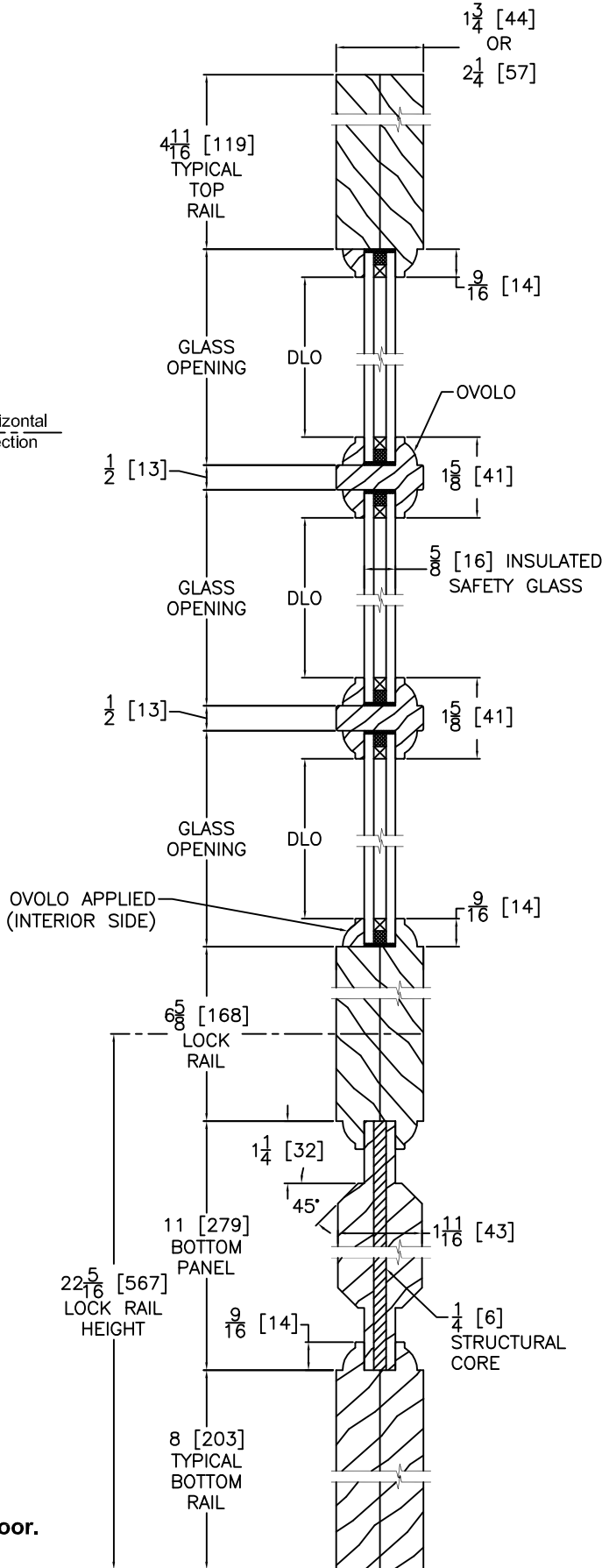
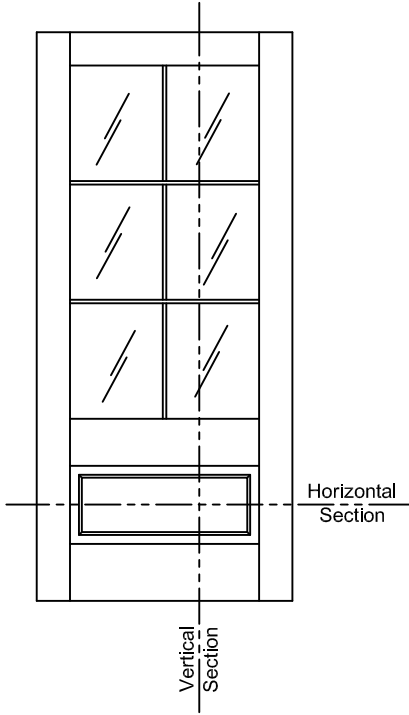

**HORIZONTAL DOOR CROSS SECTION**  
Engineered Stile Option  
(Upon Request or Doors > 3'-6" X 8'-0")

**VERTICAL DOOR/SIDLIGHT CROSS SECTION**  
Insulated Glass

**Notes:**  
Stile, Rail, Panel & Glass  
vary by Size & Model of Door.  
Typical Sizes are Shown.

