

TABLE OF CONTENTS

3 PANEL DOORS

Elevations: 1/8" Scale

33	311	1303
103	1203	1323
120	1223	3040
138	1234	

Decorative Hardware

Exterior Casing Options

Exterior/Interior Corner Block Options

Section Details

33	311	1234
103	1203	1303
120	1223	3040
138		

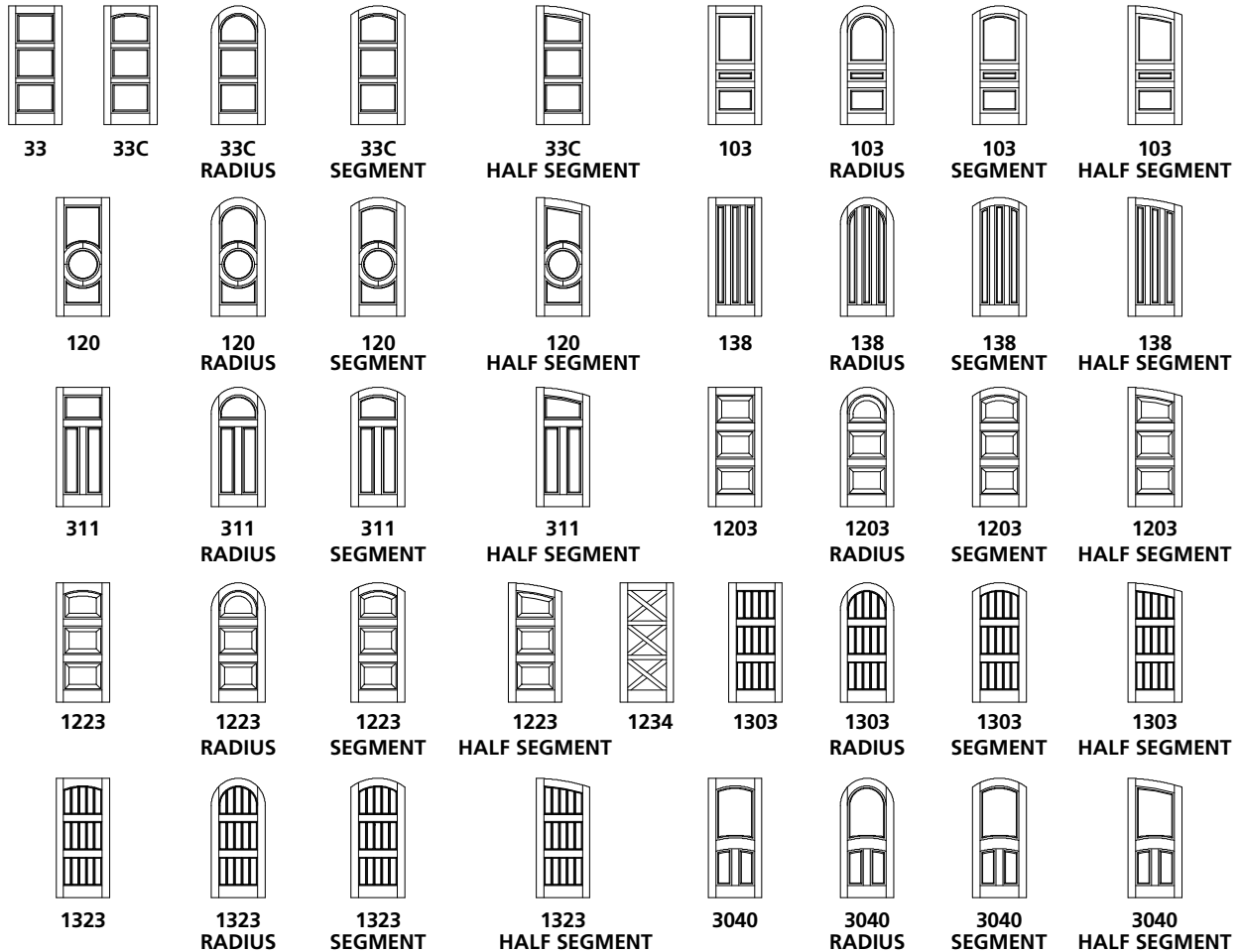

ELEVATION NOTES

Door Size = Book Size Before Prefit
 Daylight Opening (DLO) = Visible Glass
 Values in brackets [] are millimeter conversions.

DOOR CROSS-SECTION

Moulding Profile = Ovolo Sticking
 Panel Profile = Double Hip
 See 33,33C Cross Section sheet for more detail.

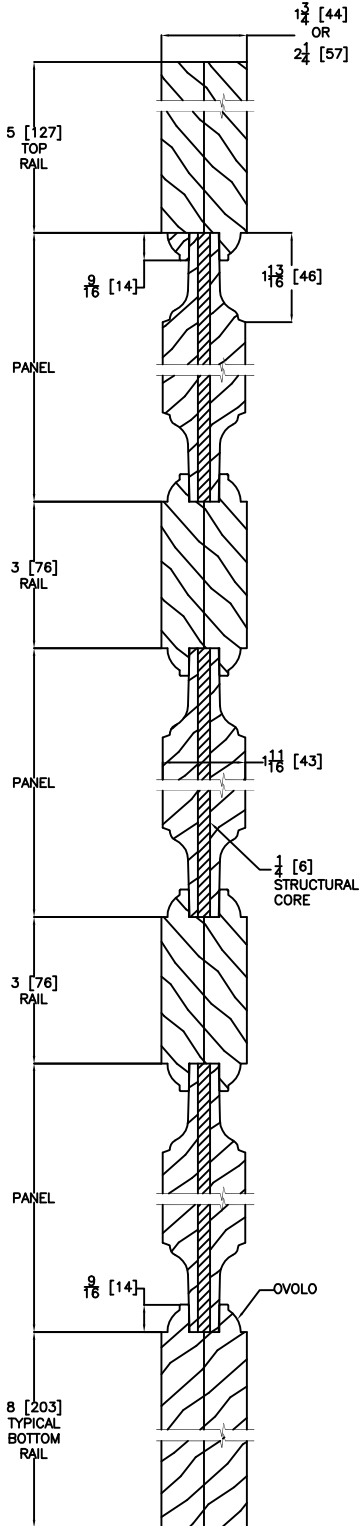

VERTICAL DOOR CROSS SECTION

33

Door Size
 Daylight Opening

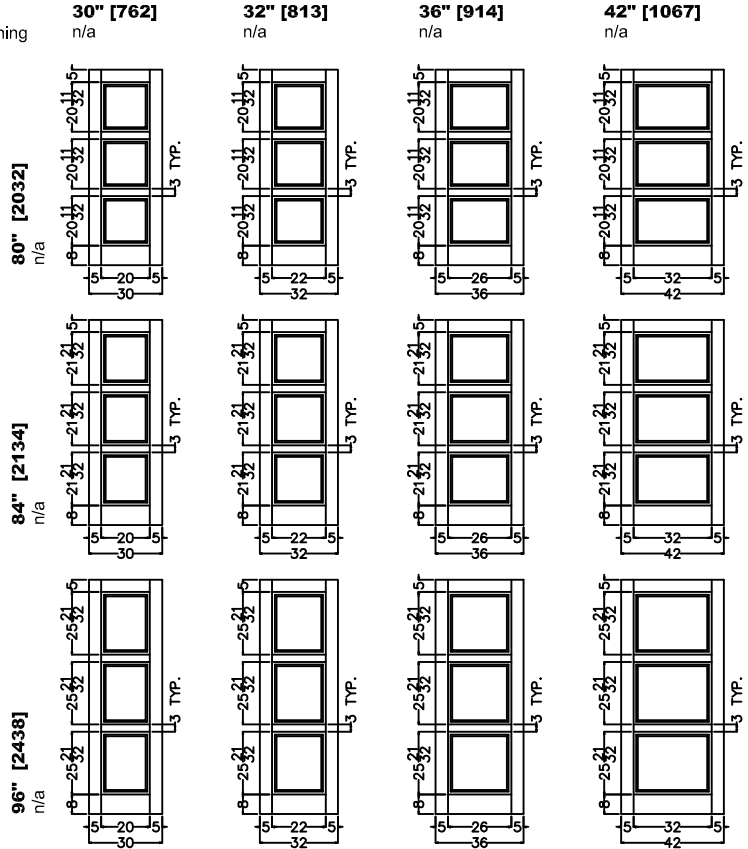

33C

Door Size
 Daylight Opening

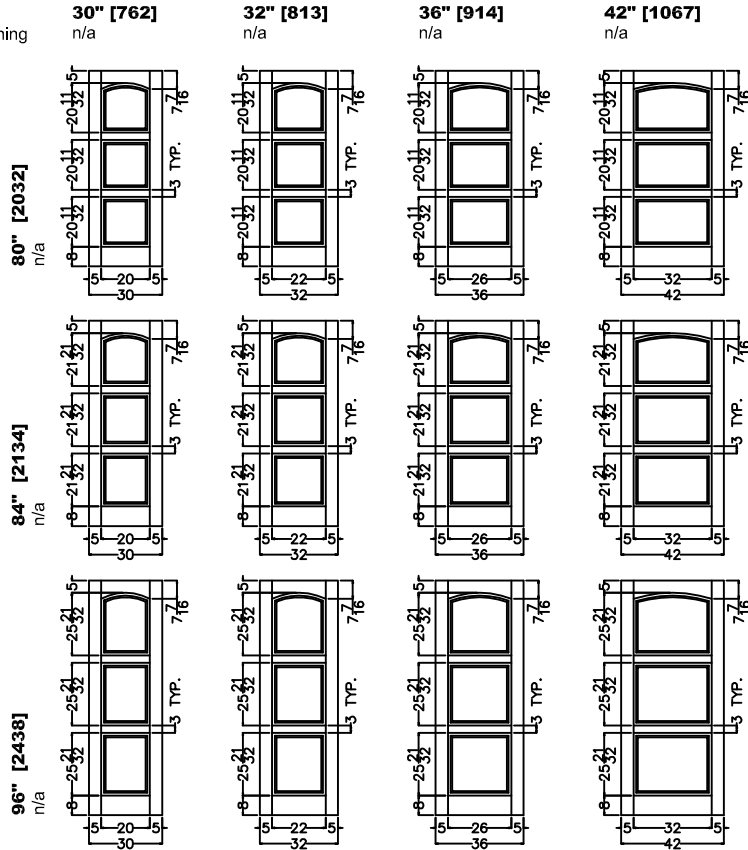

ELEVATION NOTES

Door Size = Book Size Before Prefit
 Daylight Opening (DLO) = Visible Glass
 Values in brackets [] are millimeter conversions.

DOOR CROSS-SECTION

Moulding Profile = Ovolo Sticking
 Panel Profile = Double Hip
 See 33,33C Cross Section sheet for more detail.

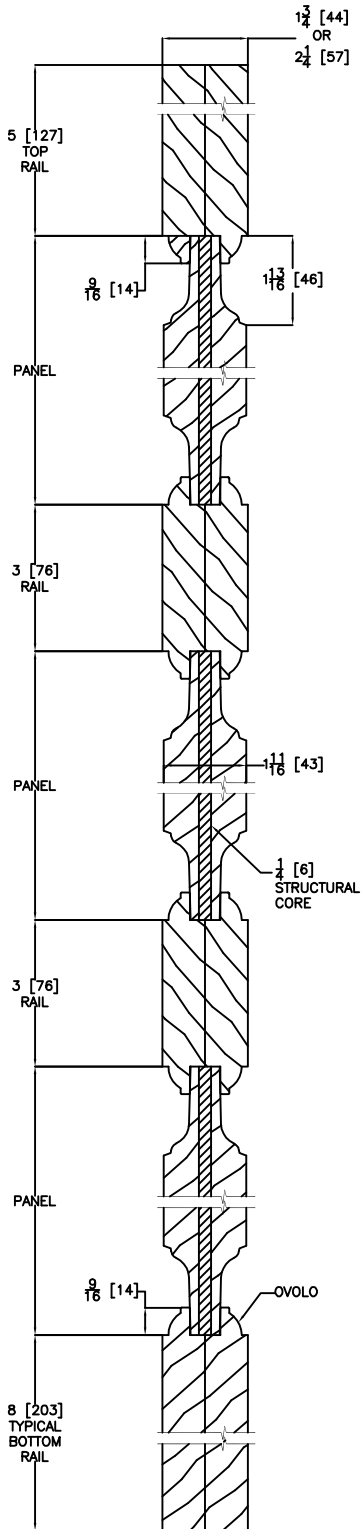

VERTICAL DOOR CROSS SECTION

RADIUS

Door Size
 Daylight Opening

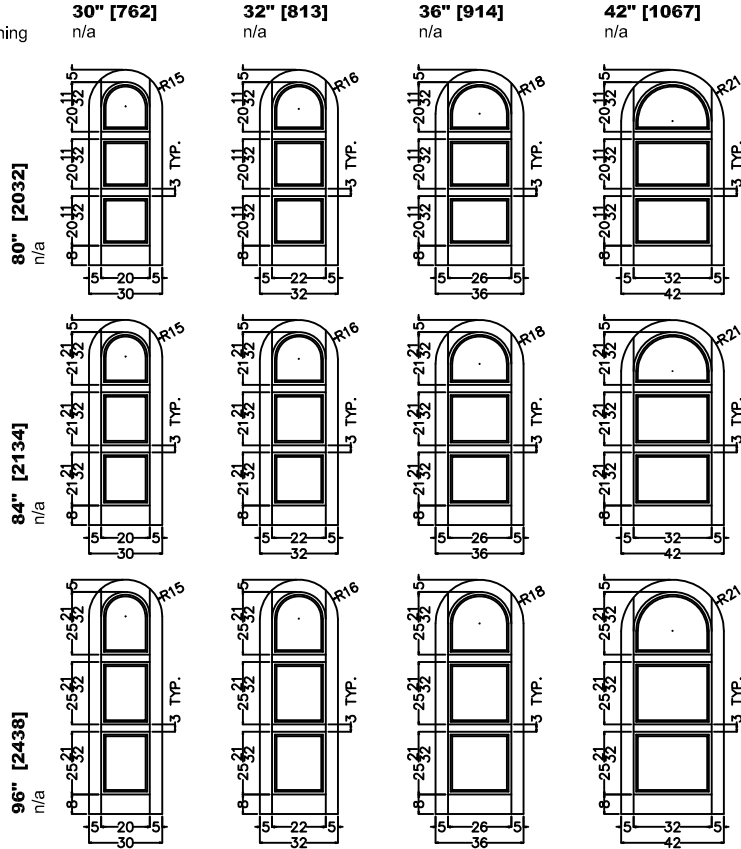

ELEVATION NOTES

Door Size = Book Size Before Prefit
 Daylight Opening (DLO) = Visible Glass
 Values in brackets [] are millimeter conversions.

DOOR CROSS-SECTION

Moulding Profile = Ovolo Sticking
 Panel Profile = Double Hip
 See 33,33C Cross Section sheet for more detail.

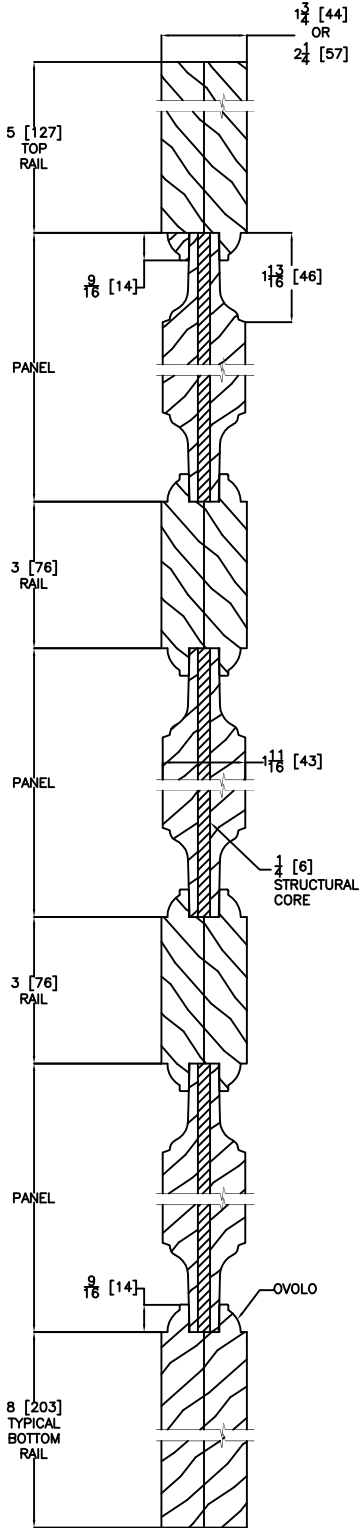

VERTICAL DOOR CROSS SECTION

SEGMENT

Door Size
 Daylight Opening

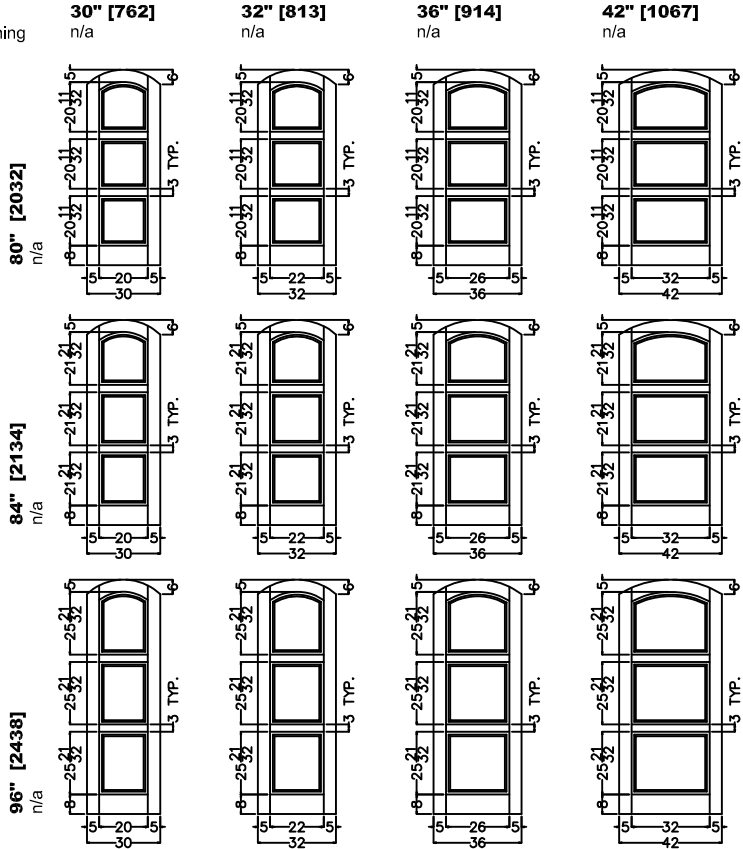

HALF SEGMENT

Door Size
 Daylight Opening

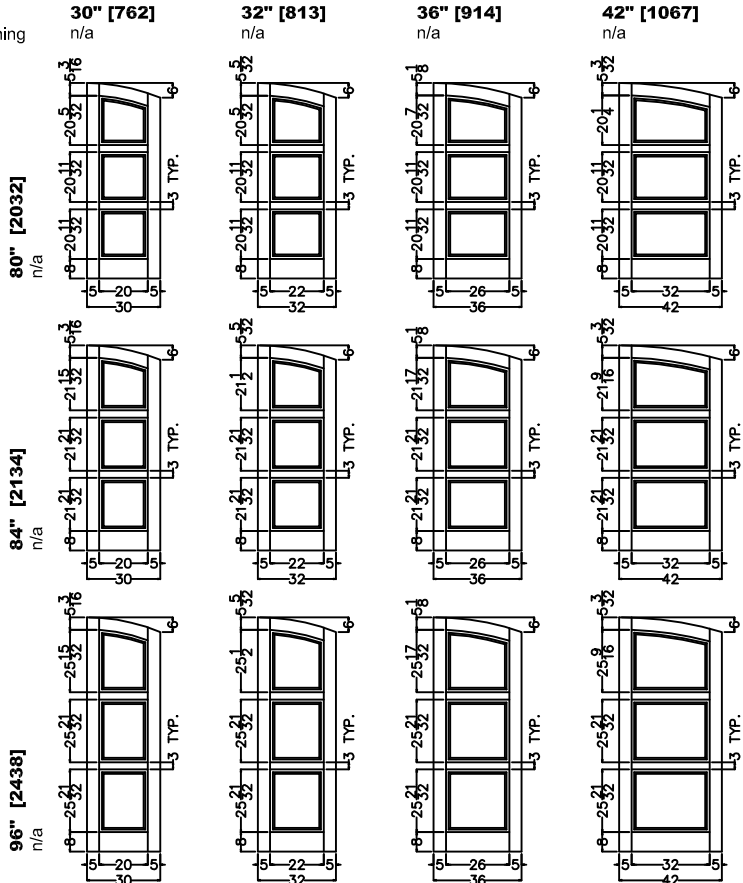

ELEVATION NOTES

Door Size = Book Size Before Prefit
 Daylight Opening (DLO) = Visible Glass
 Values in brackets [] are millimeter conversions.

DOOR CROSS-SECTION

Moulding Profile = 112
 Panel Profile = Double Hip
 See 103 Cross Section sheet for more detail.

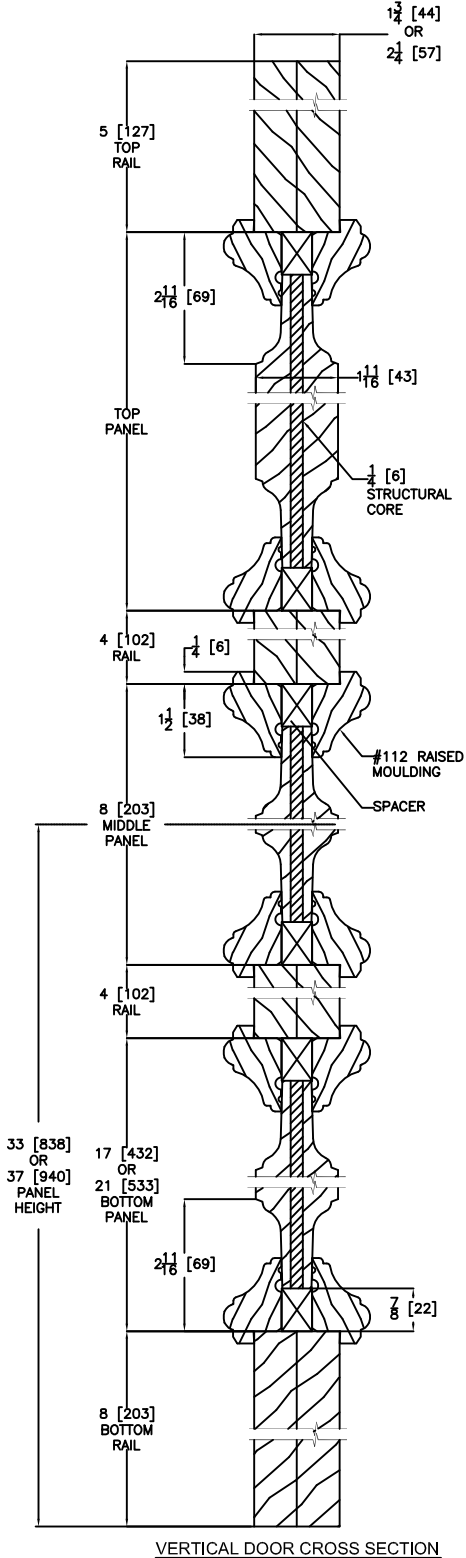

Door Size	30" [762]	32" [813]	36" [914]	42" [1067]
Daylight Opening	n/a	n/a	n/a	n/a
80" [2032]	n/a	n/a	n/a	n/a
84" [2134]	n/a	n/a	n/a	n/a
96" [2438]	n/a	n/a	n/a	n/a

Sidelight Size	12" [305]	13" [330]	14" [356]	15" [381]	16" [406]	17" [432]	18" [457]
Daylight Opening	6" [152]	6" [152]	6" [152]	8" [203]	8" [203]	8" [203]	8" [203]
80" [2032]	43" [1092]						
84" [2134]	47" [1194]						
96" [2438]	55" [1397]						

ELEVATION NOTES

Door Size = Book Size Before Prefit
 Daylight Opening (DLO) = Visible Glass
 Values in brackets [] are millimeter conversions.

DOOR CROSS-SECTION

Moulding Profile = 112
 Panel Profile = Double Hip
 See 103 Cross Section sheet for more detail.

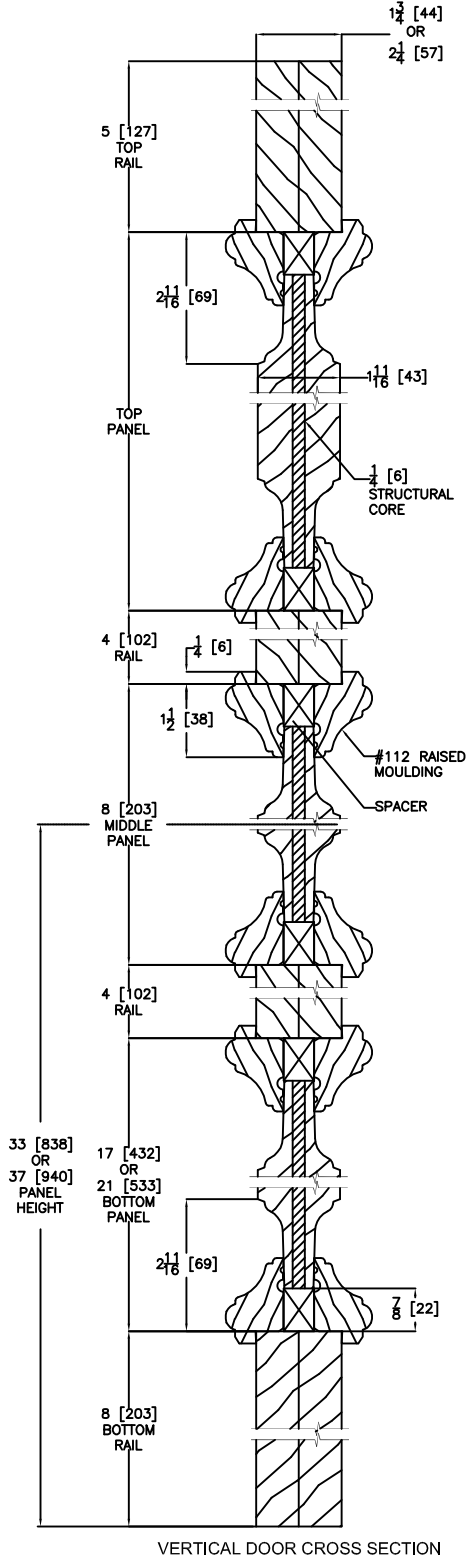

RADIUS

Door Size
 Daylight Opening

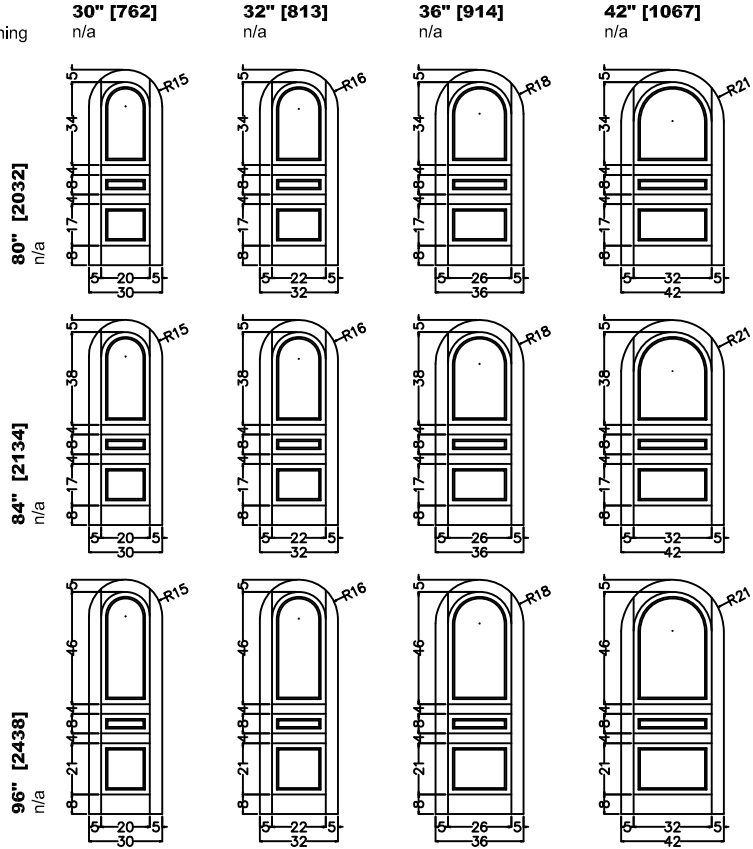

ELEVATION NOTES

Door Size = Book Size Before Prefit
 Daylight Opening (DLO) = Visible Glass
 Values in brackets [] are millimeter conversions.

DOOR CROSS-SECTION

Moulding Profile = 112
 Panel Profile = Double Hip
 See 103 Cross Section sheet for more detail.

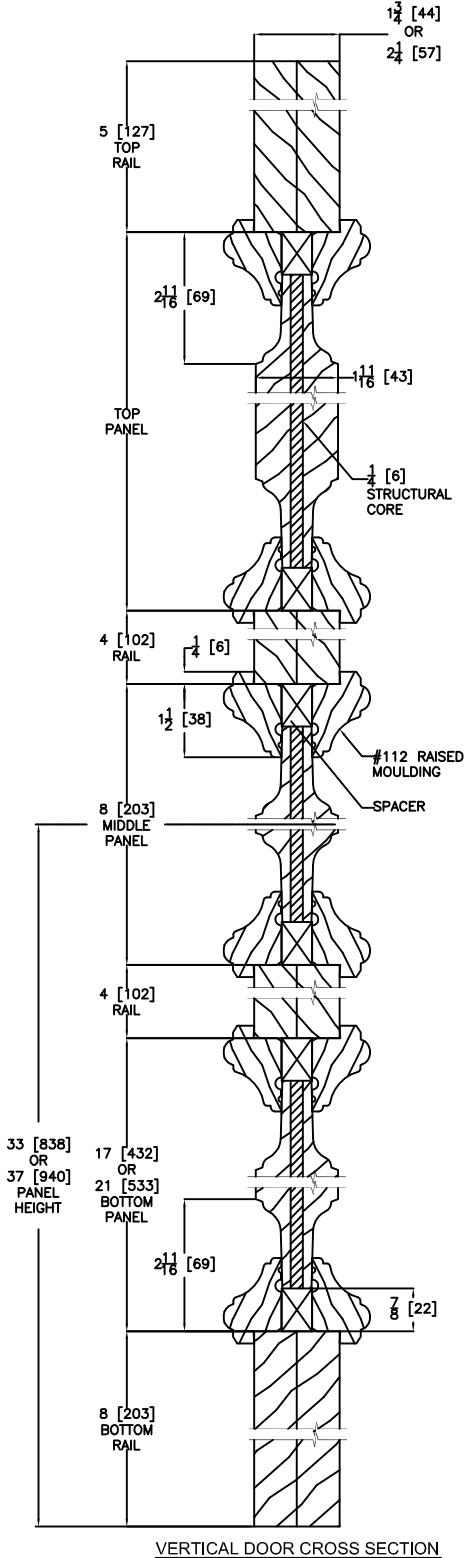

SEGMENT

Door Size
Daylight Opening

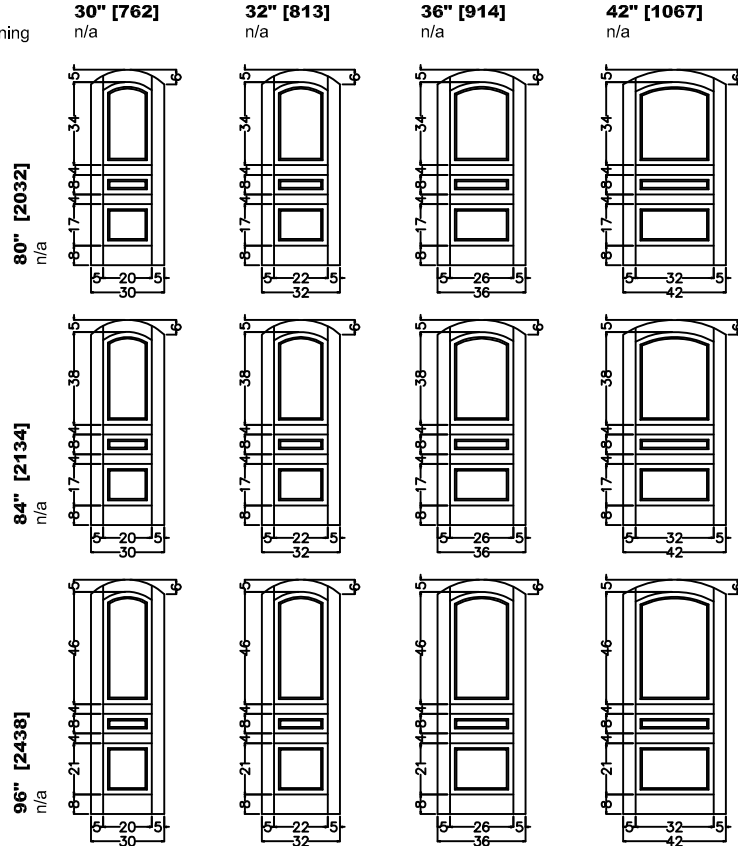

HALF SEGMENT

Door Size
Daylight Opening

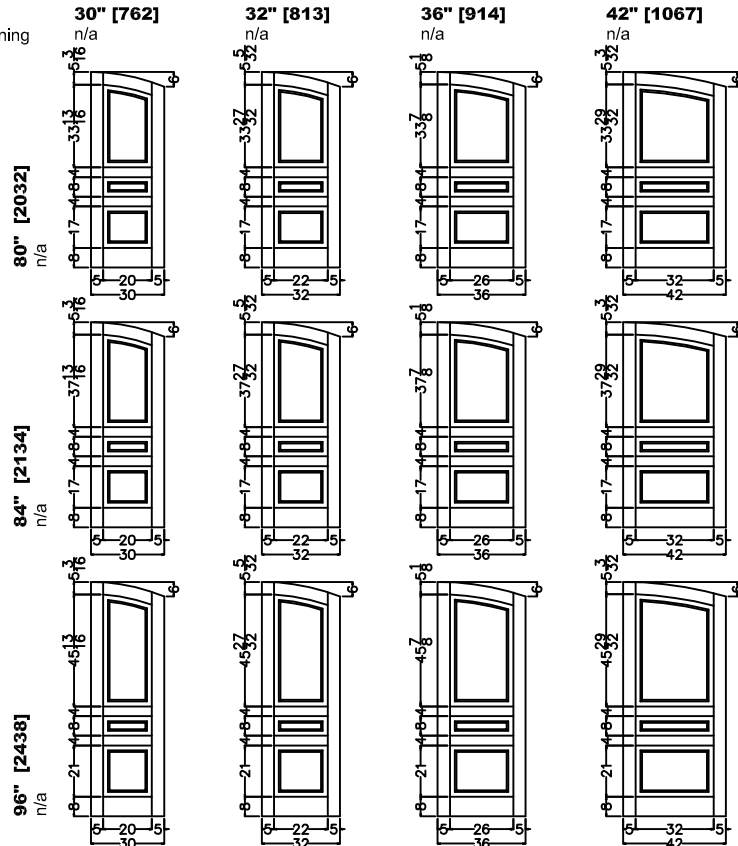

ELEVATION NOTES

Door Size = Book Size Before Prefit
 Daylight Opening (DLO) = Visible Glass
 Values in brackets [] are millimeter conversions.

DOOR CROSS-SECTION

Moulding Profile = 141
 Panel Profile = 45 Degree
 See 120 Cross Section sheet for more detail.

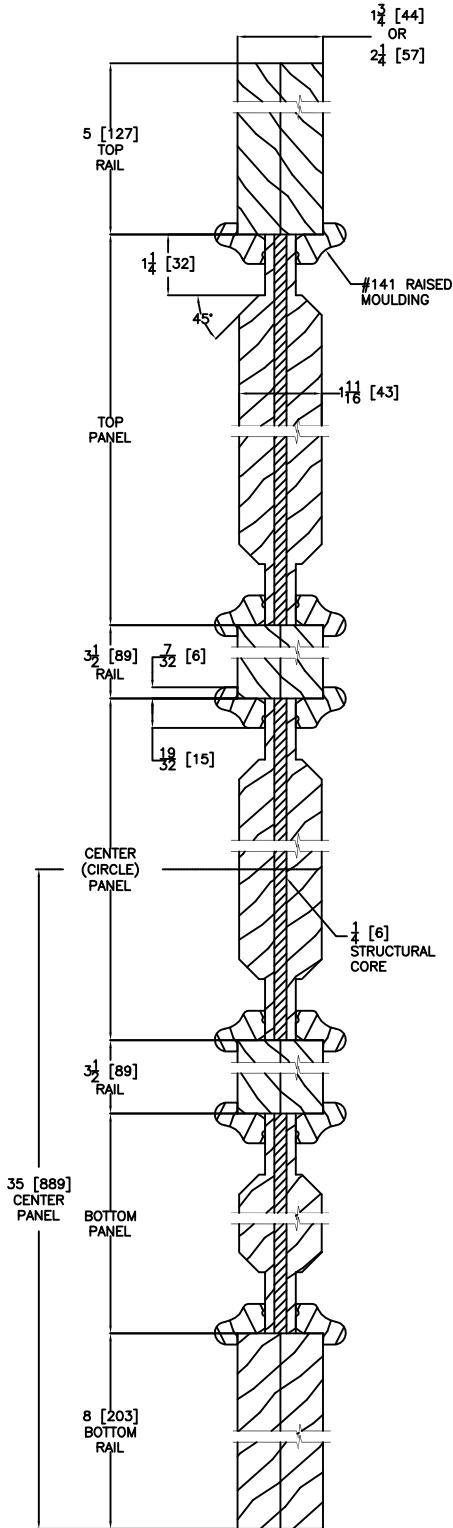

Door Size
 Daylight Opening

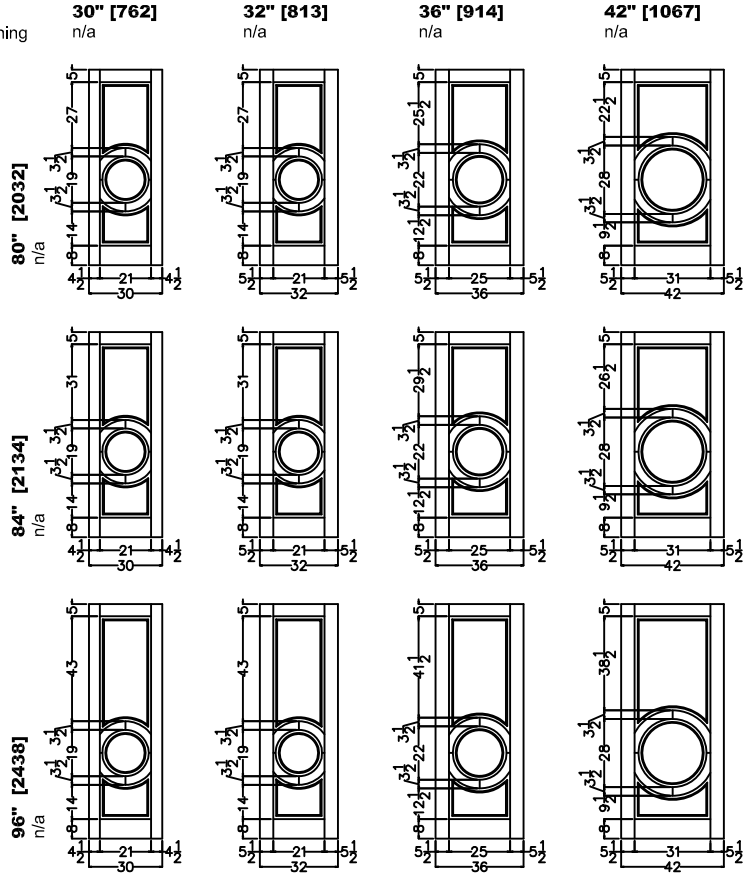

VERTICAL DOOR CROSS SECTION

ELEVATION NOTES

Door Size = Book Size Before Prefit
 Daylight Opening (DLO) = Visible Glass
 Values in brackets [] are millimeter conversions.

DOOR CROSS-SECTION

Moulding Profile = 141
 Panel Profile = 45 Degree
 See 120 Cross Section sheet for more detail.

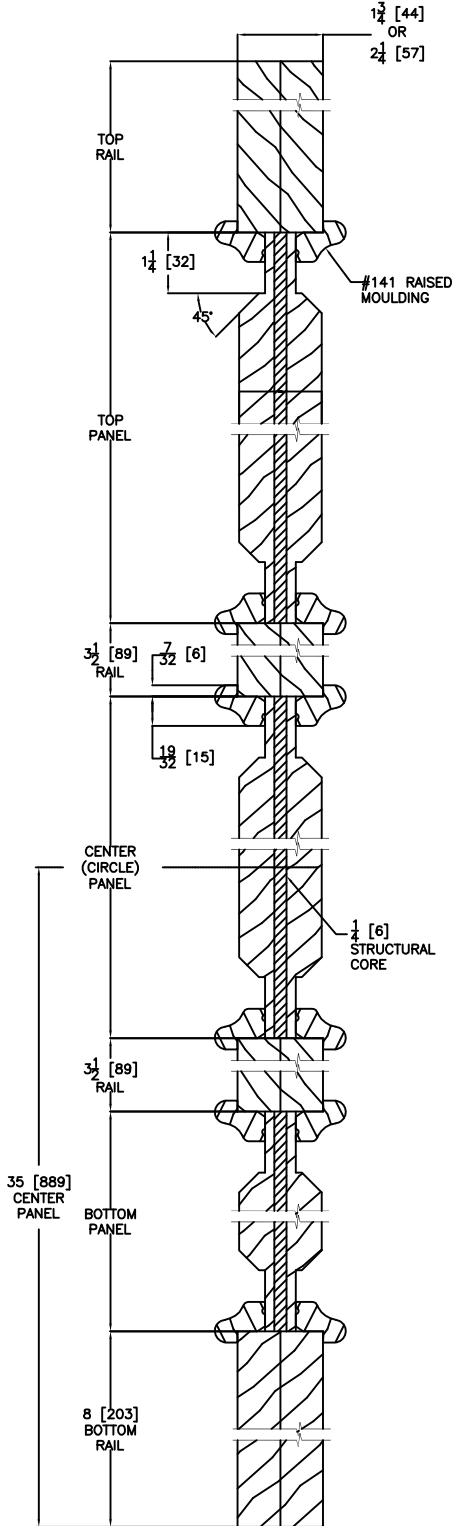

RADIUS

Door Size
 Daylight Opening

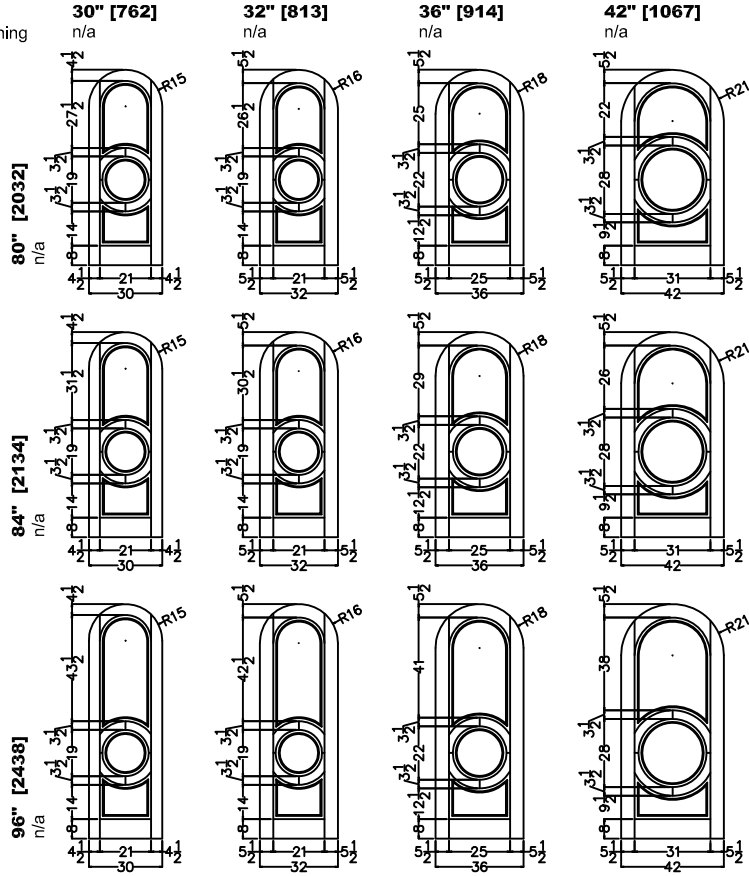

VERTICAL DOOR CROSS SECTION

ELEVATION NOTES

Door Size = Book Size Before Prefit
 Daylight Opening (DLO) = Visible Glass
 Values in brackets [] are millimeter conversions.

DOOR CROSS-SECTION

Moulding Profile = 141
 Panel Profile = 45 Degree
 See 120 Cross Section sheet for more detail.

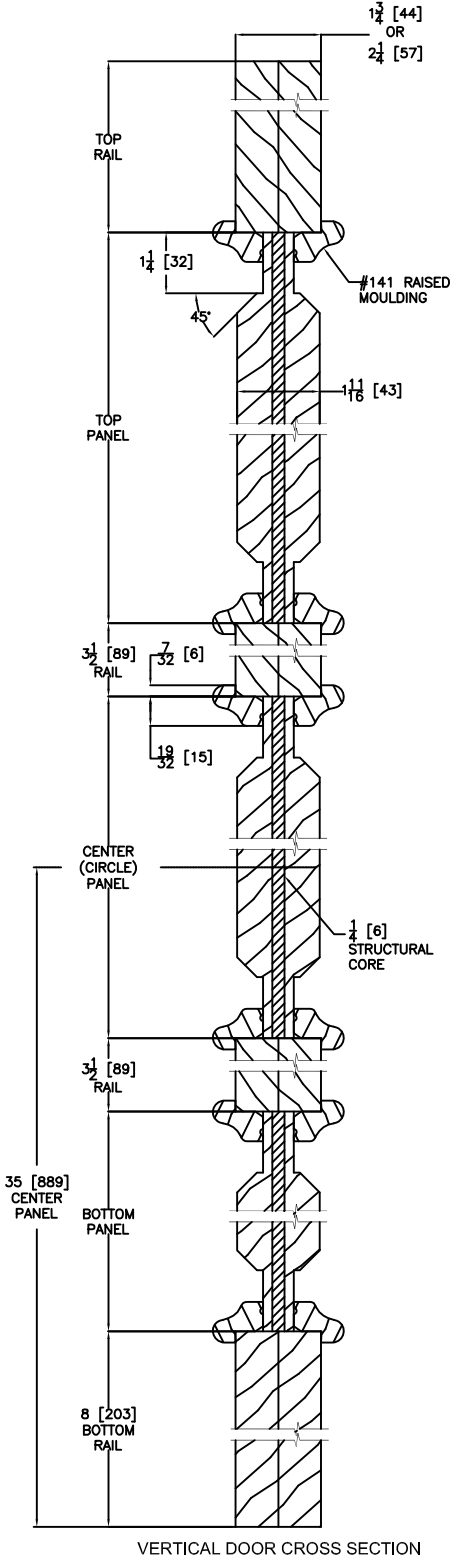

SEGMENT

Door Size
 Daylight Opening

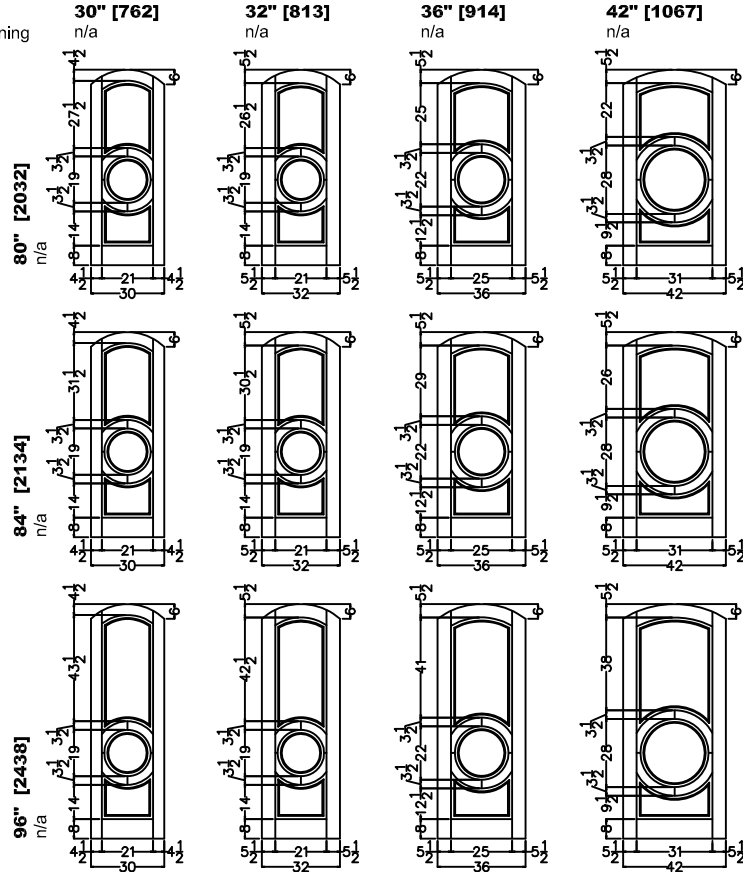

HALF SEGMENT

Door Size
 Daylight Opening

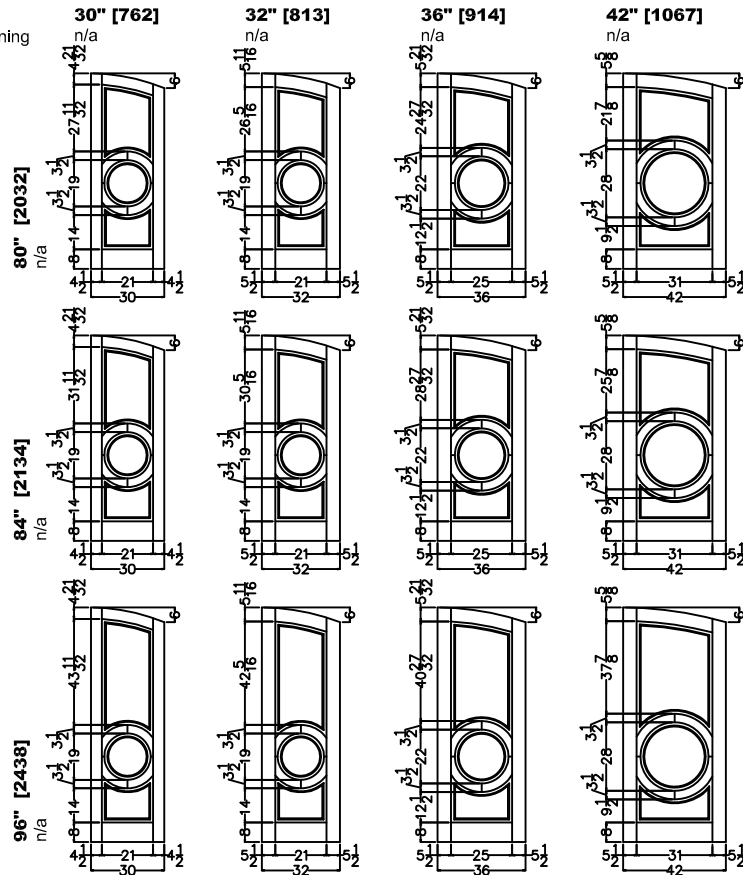

ELEVATION NOTES

Door Size = Book Size Before Prefit
 Daylight Opening (DLO) = Visible Glass
 Values in brackets [] are millimeter conversions.

DOOR CROSS-SECTION

Moulding Profile = Ovolo Sticking
 Panel Profile = Double Hip
 See 138 Cross Section sheet for more detail.

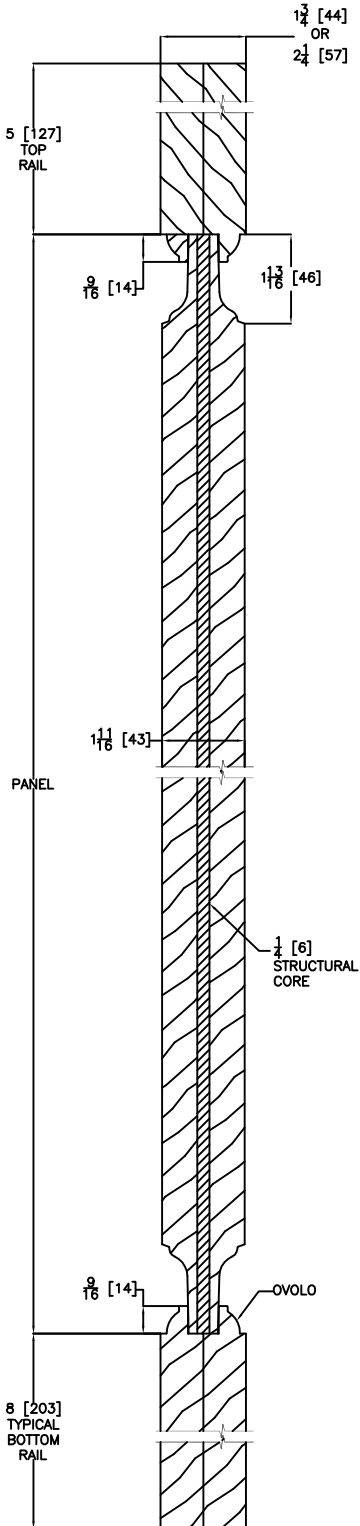

Door Size
 Daylight Opening

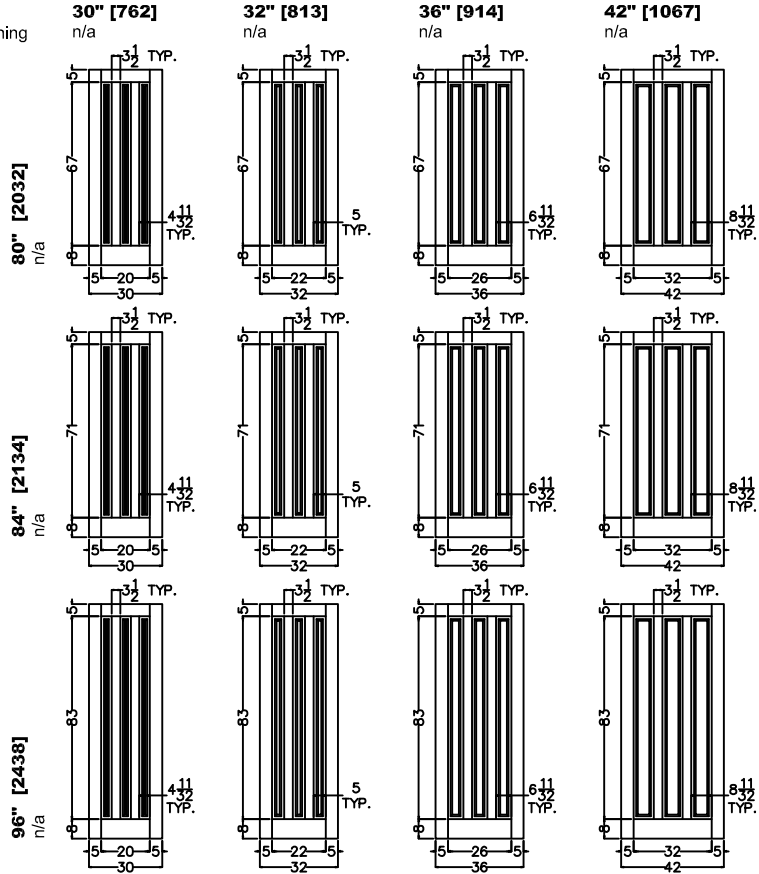

VERTICAL DOOR CROSS SECTION

ELEVATION NOTES

Door Size = Book Size Before Prefit
 Daylight Opening (DLO) = Visible Glass
 Values in brackets [] are millimeter conversions.

DOOR CROSS-SECTION

Moulding Profile = Ovolo Sticking
 Panel Profile = Double Hip
 See 138 Cross Section sheet for more detail.

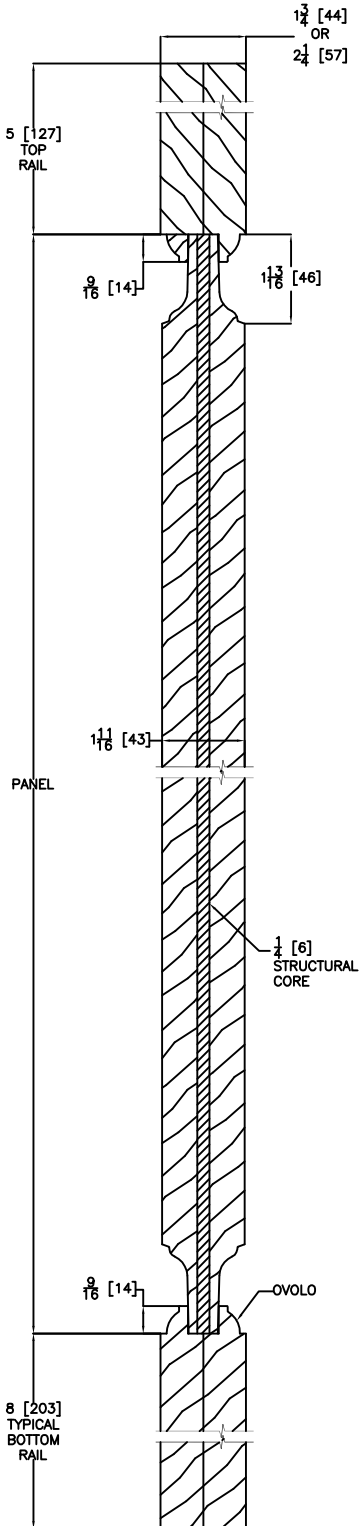

RADIUS

Door Size
 Daylight Opening

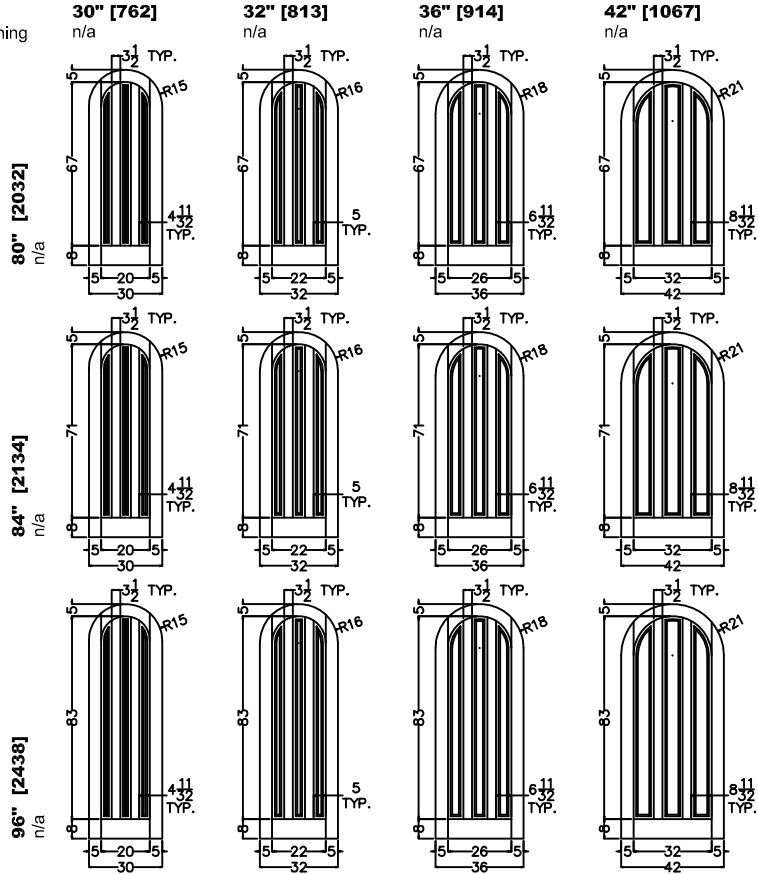

VERTICAL DOOR CROSS SECTION

ELEVATION NOTES

Door Size = Book Size Before Prefit
 Daylight Opening (DLO) = Visible Glass
 Values in brackets [] are millimeter conversions.

DOOR CROSS-SECTION

Moulding Profile = Ovolo Sticking
 Panel Profile = Double Hip
 See 138 Cross Section sheet for more detail.

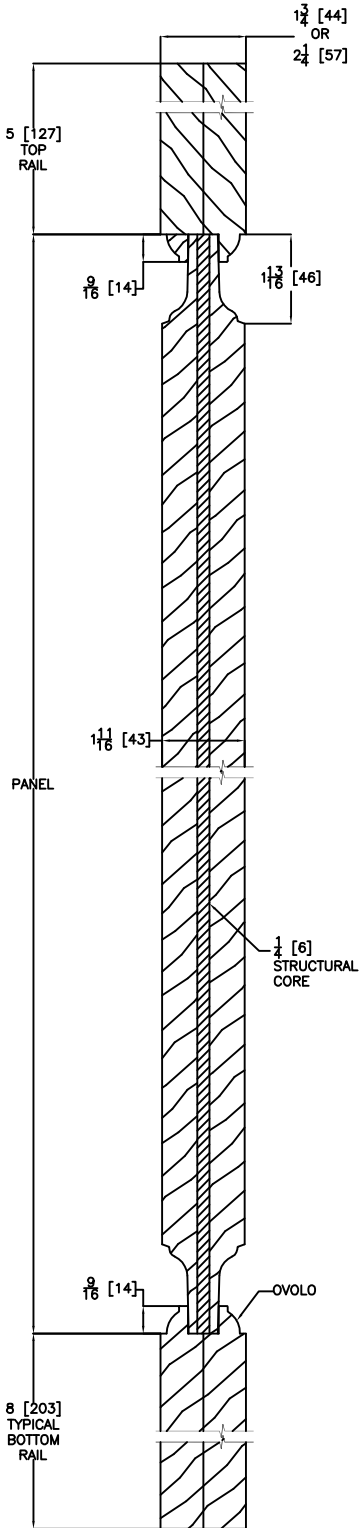

VERTICAL DOOR CROSS SECTION

SEGMENT

Door Size
 Daylight Opening

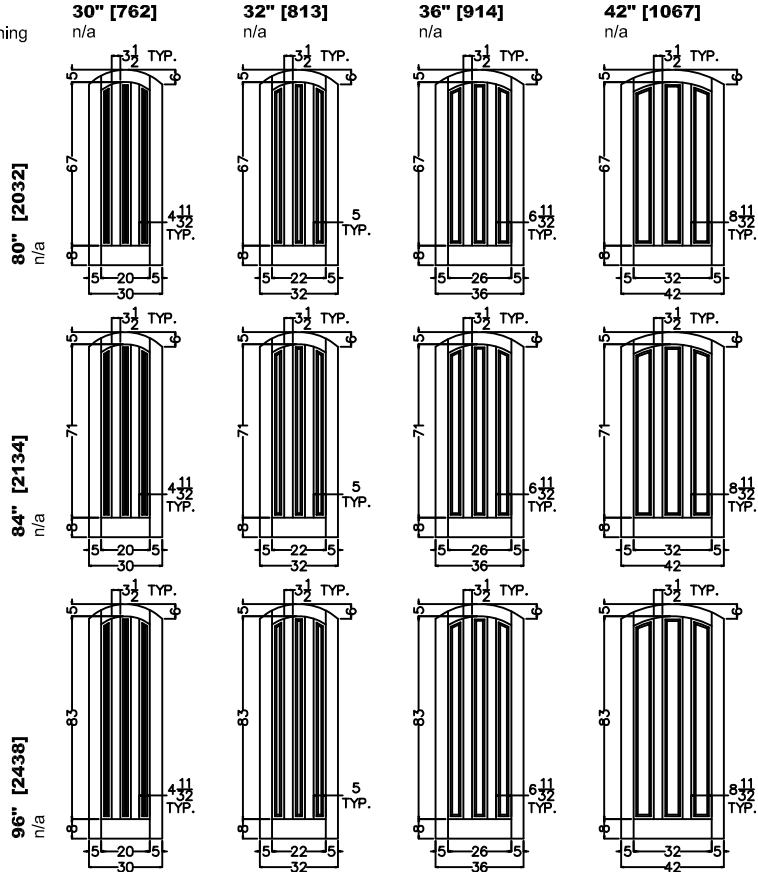

HALF SEGMENT

Door Size
 Daylight Opening

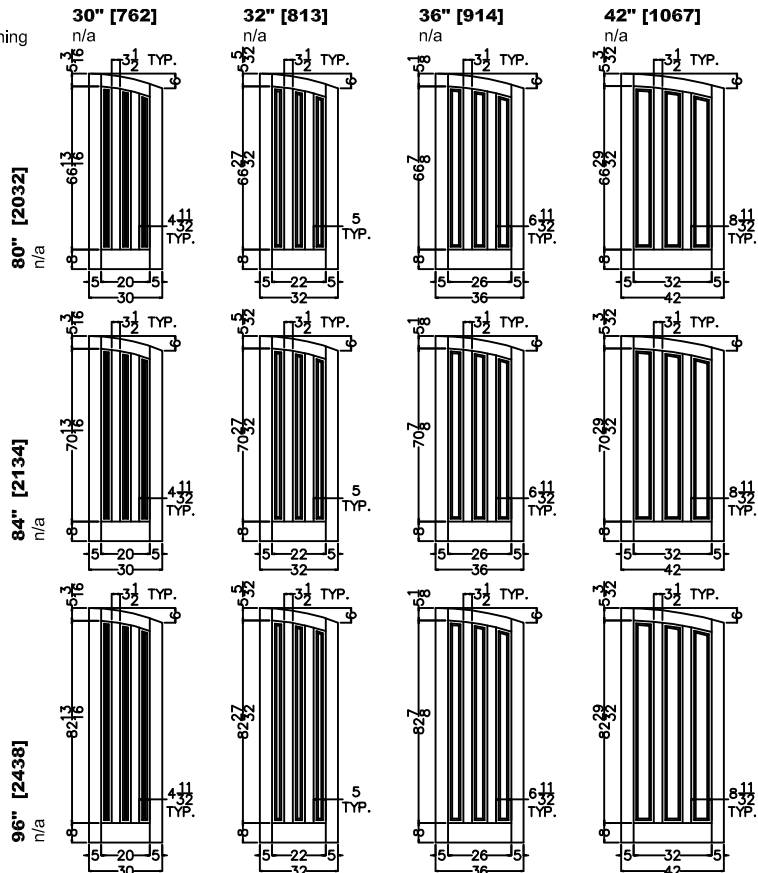

ELEVATION NOTES

Door Size = Book Size Before Prefit
 Daylight Opening (DLO) = Visible Glass
 Values in brackets [] are millimeter conversions.

DOOR CROSS-SECTION

Moulding Profile = Ovolo Sticking
 Panel Profile = Double Hip
 See 311 Cross Section sheet for more detail.

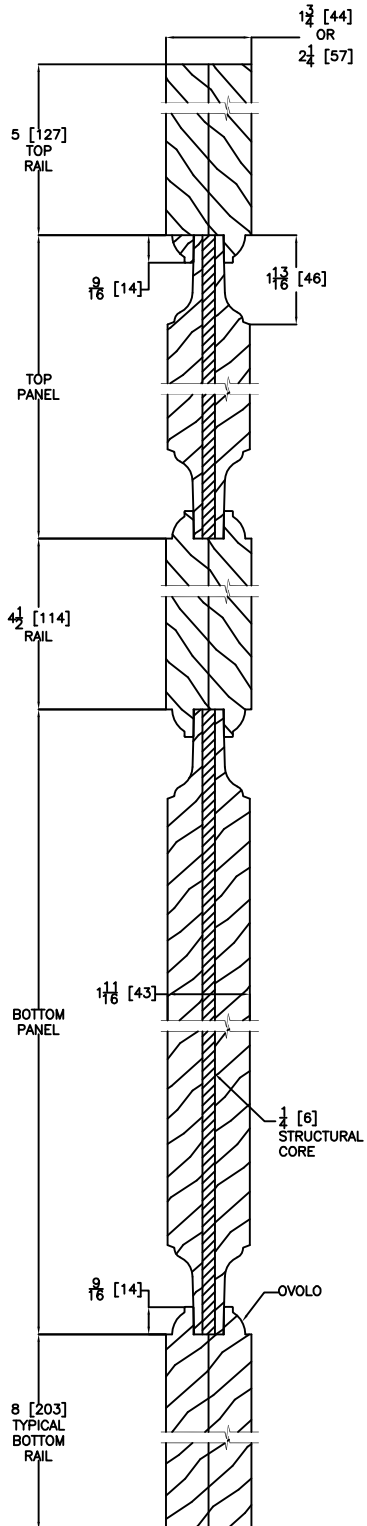

Door Size
 Daylight Opening

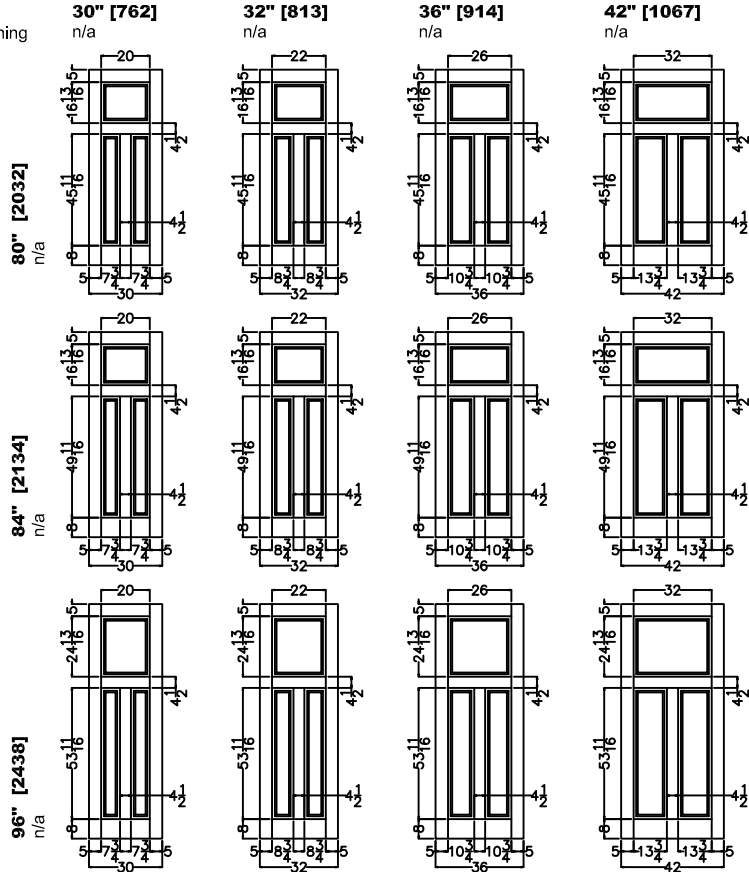

VERTICAL DOOR CROSS SECTION

ELEVATION NOTES

Door Size = Book Size Before Prefit
 Daylight Opening (DLO) = Visible Glass
 Values in brackets [] are millimeter conversions.

DOOR CROSS-SECTION

Moulding Profile = Ovolo Sticking
 Panel Profile = Double Hip
 See 311 Cross Section sheet for more detail.

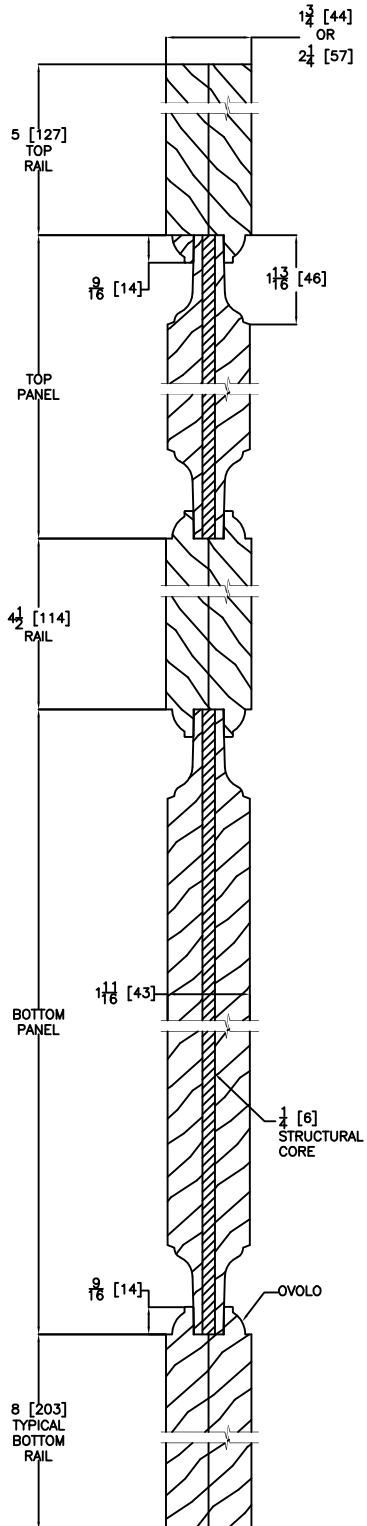

RADIUS

Door Size
 Daylight Opening

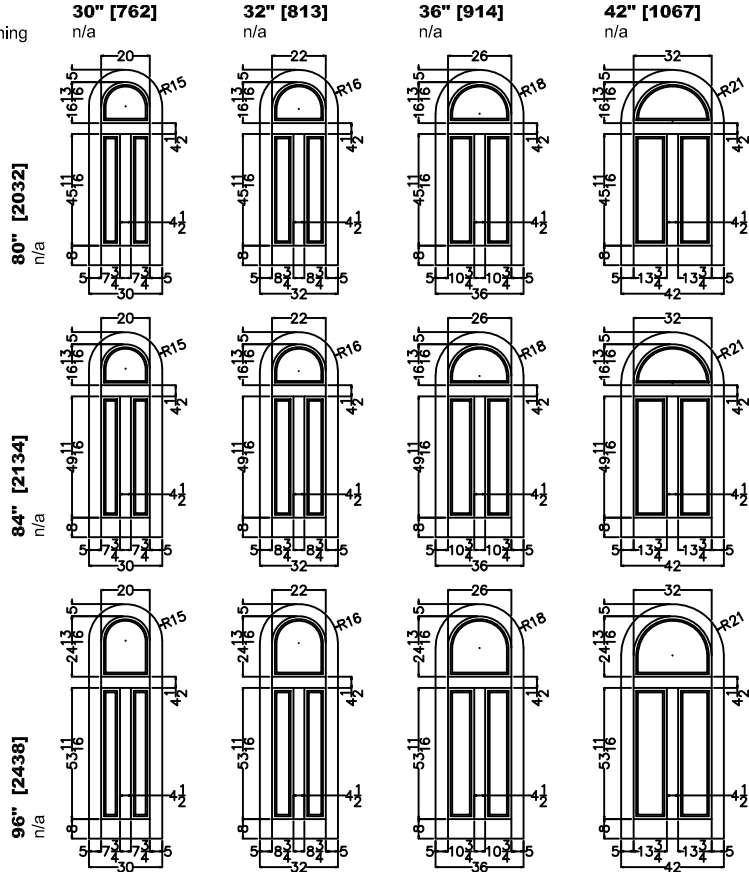

VERTICAL DOOR CROSS SECTION

ELEVATION NOTES

Door Size = Book Size Before Prefit
 Daylight Opening (DLO) = Visible Glass
 Values in brackets [] are millimeter conversions.

DOOR CROSS-SECTION

Moulding Profile = Ovolo Sticking
 Panel Profile = Double Hip
 See 311 Cross Section sheet for more detail.

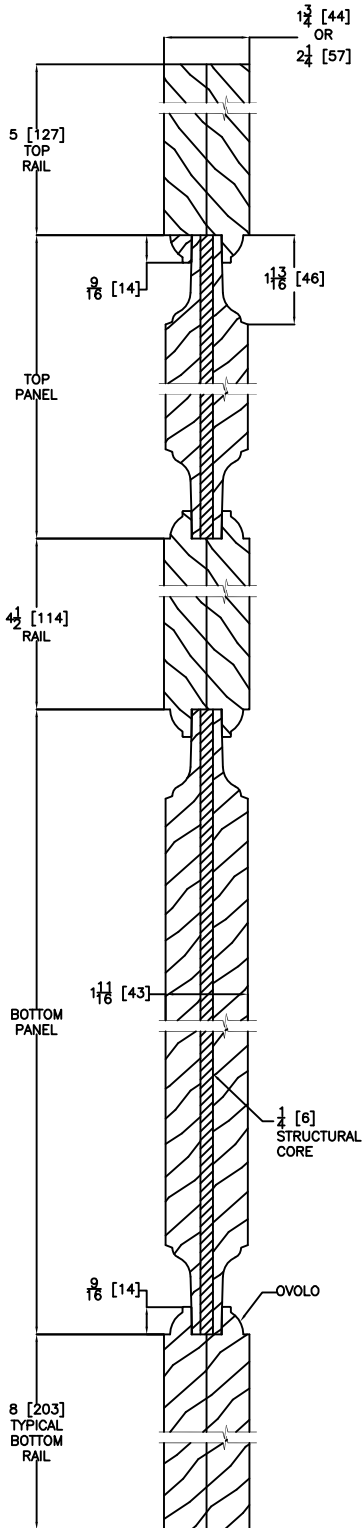

SEGMENT

Door Size
 Daylight Opening

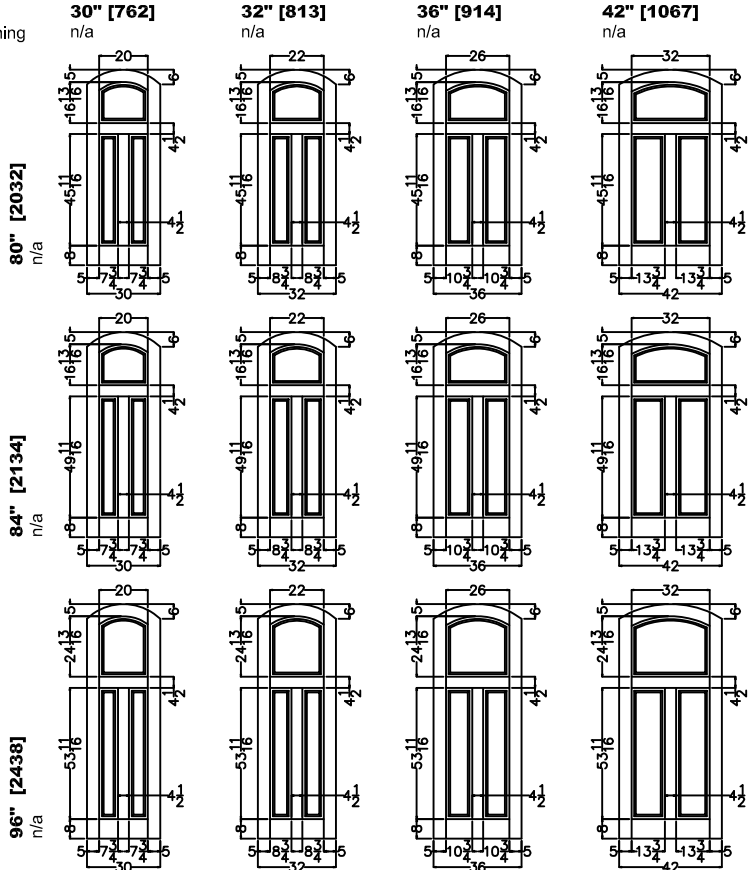

HALF SEGMENT

Door Size
 Daylight Opening

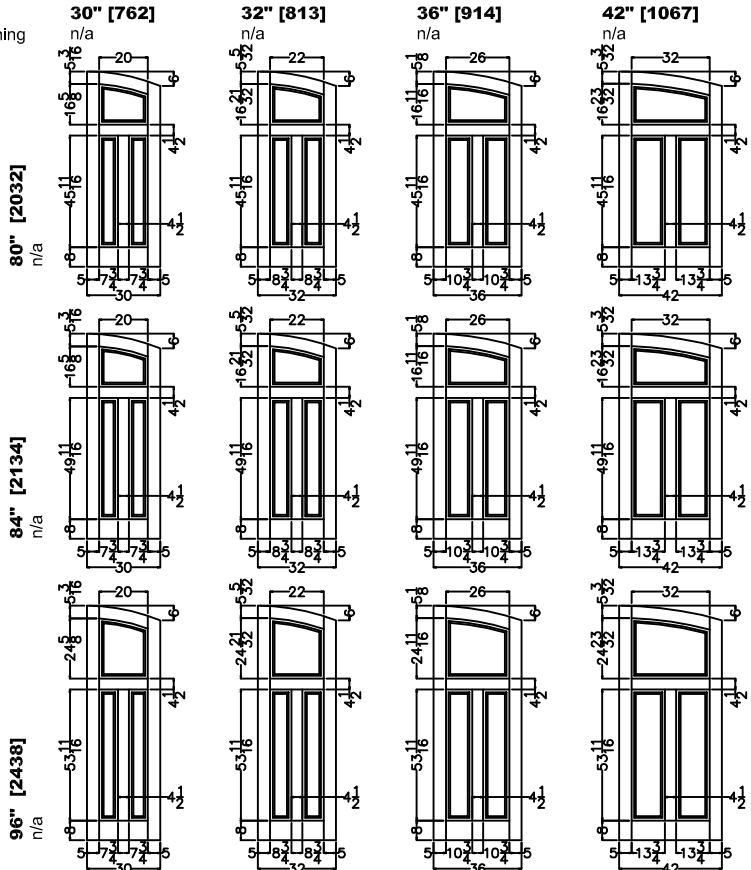

VERTICAL DOOR CROSS SECTION

ELEVATION NOTES

Door Size = Book Size Before Prefit
 Daylight Opening (DLO) = Visible Glass
 Values in brackets [] are millimeter conversions.

DOOR CROSS-SECTION

Moulding Profile = 1200
 Panel Profile = Convex Long
 See 1203 Cross Section sheet for more detail.

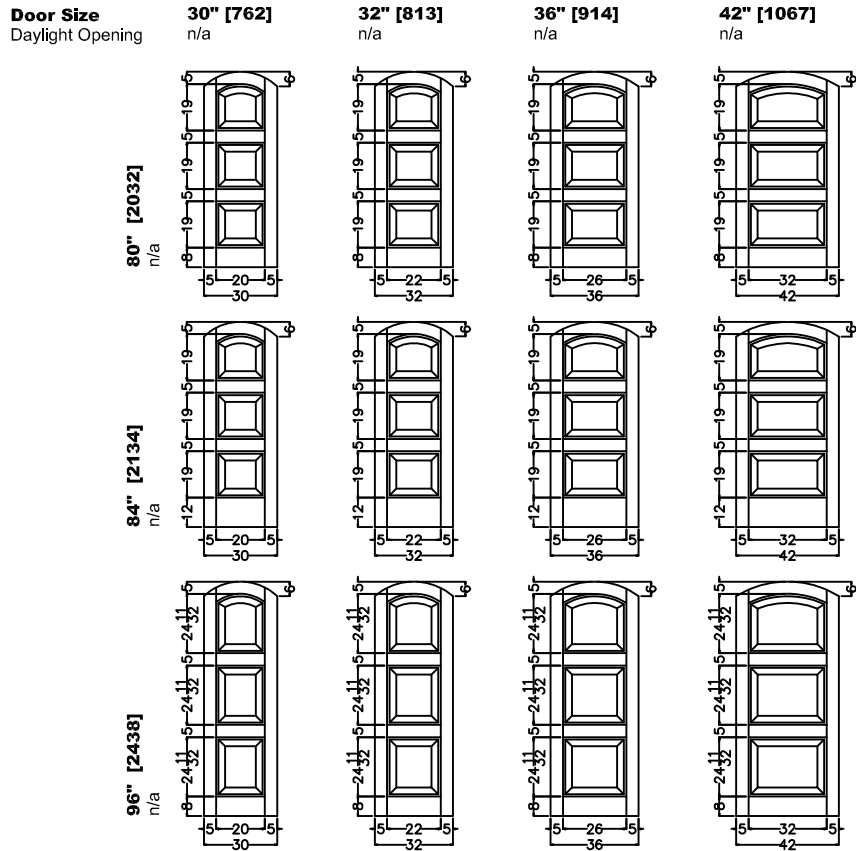
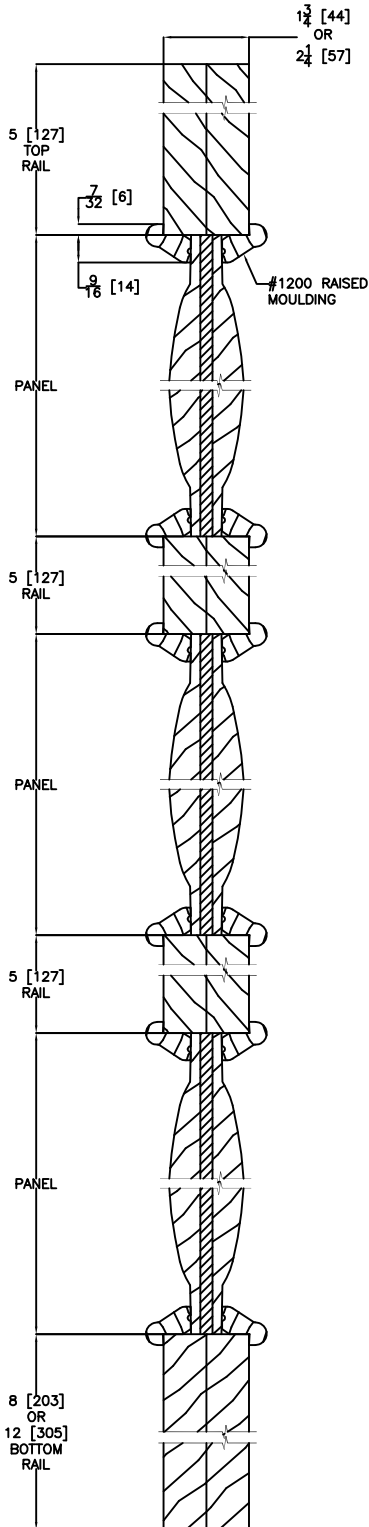

STRAP PLACEMENT

(Hardware Optional/Custom Placement Available)

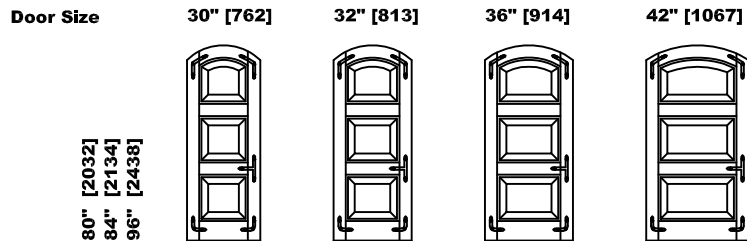

VERTICAL DOOR CROSS SECTION

ELEVATION NOTES

Door Size = Book Size Before Prefit
 Daylight Opening (DLO) = Visible Glass
 Values in brackets [] are millimeter conversions.

DOOR CROSS-SECTION

Moulding Profile = 1200
 Panel Profile = Convex Long
 See 1203 Cross Section sheet for more detail.

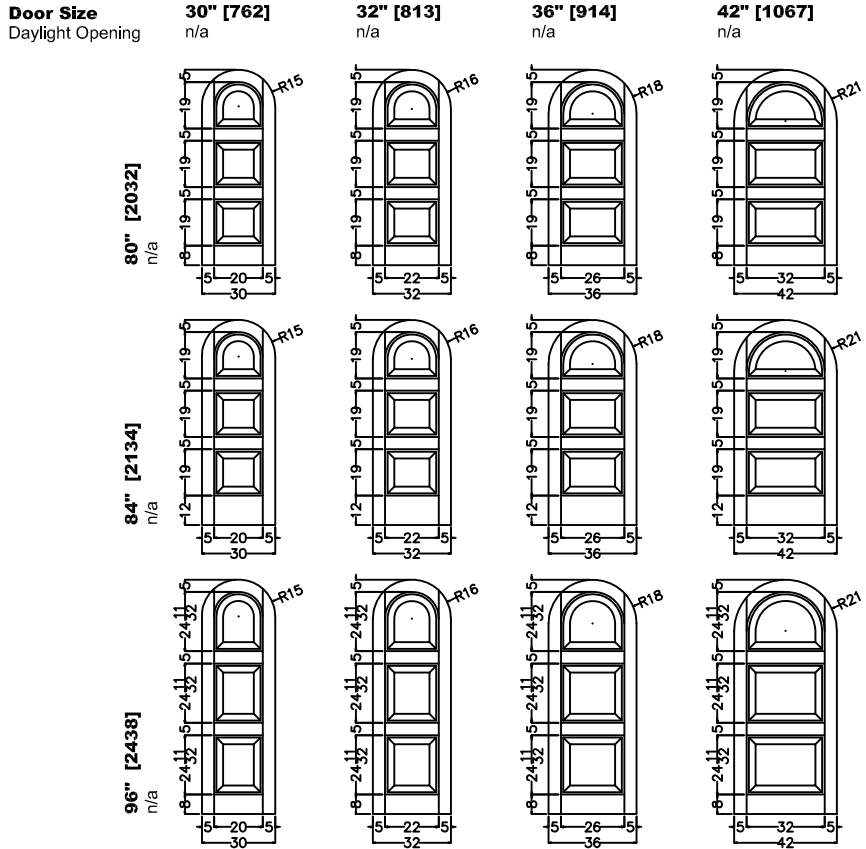
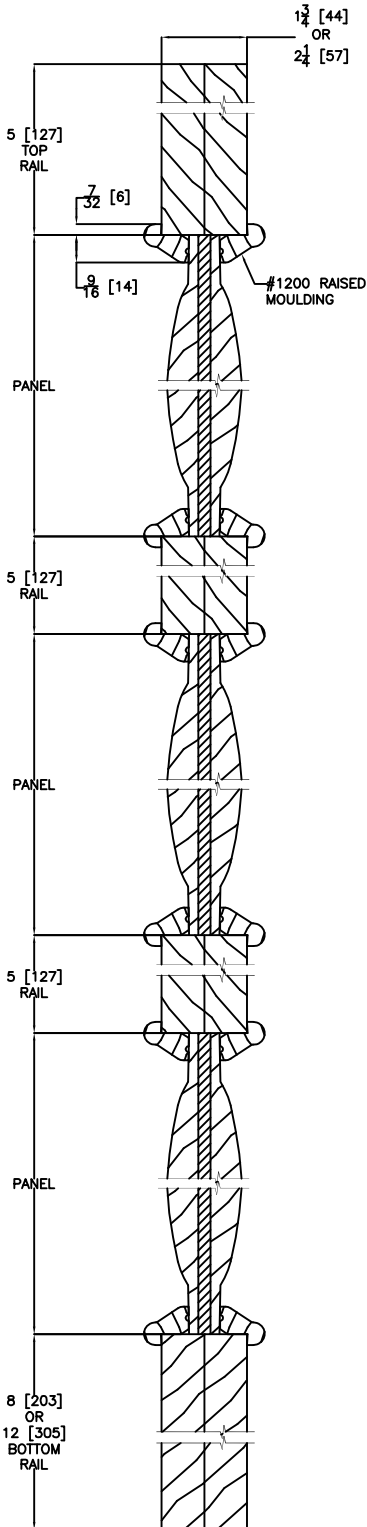

STRAP PLACEMENT (Hardware Optional/Custom Placement Available)

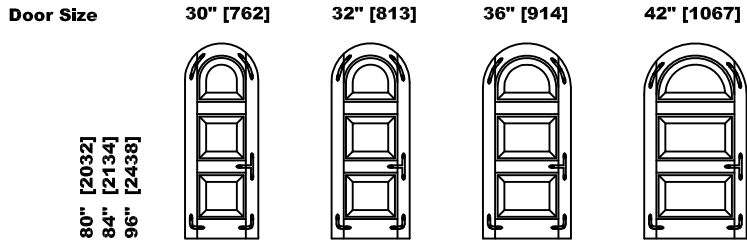

VERTICAL DOOR CROSS SECTION

ELEVATION NOTES

Door Size = Book Size Before Prefit
 Daylight Opening (DLO) = Visible Glass
 Values in brackets [] are millimeter conversions.

DOOR CROSS-SECTION

Moulding Profile = 1200
 Panel Profile = Convex Long
 See 1223 Cross Section sheet for more detail.

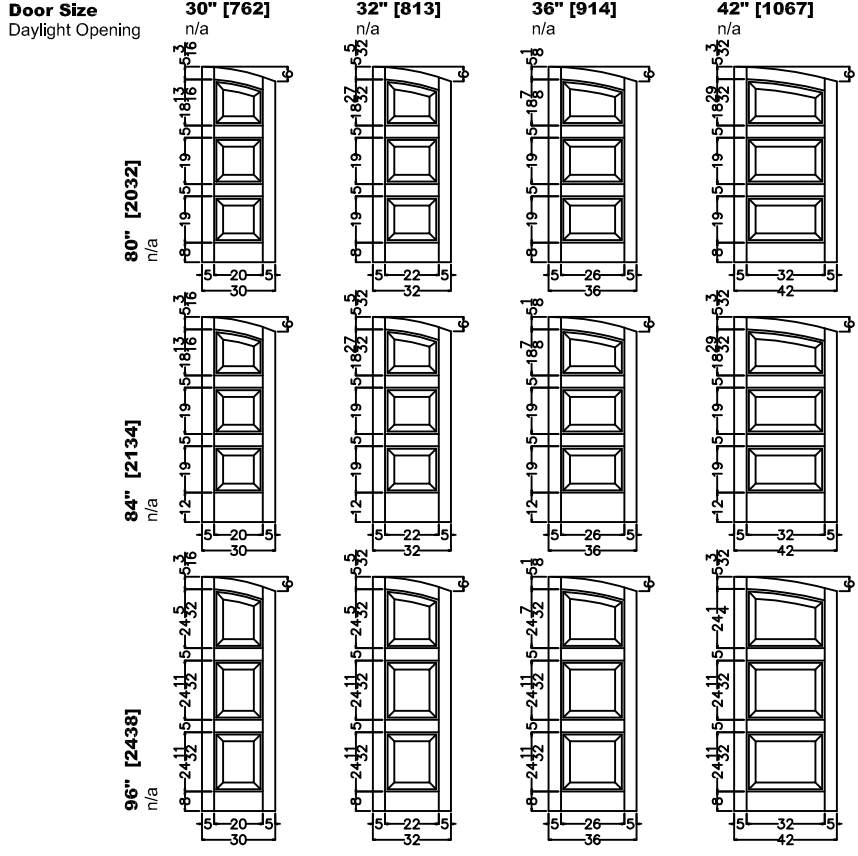
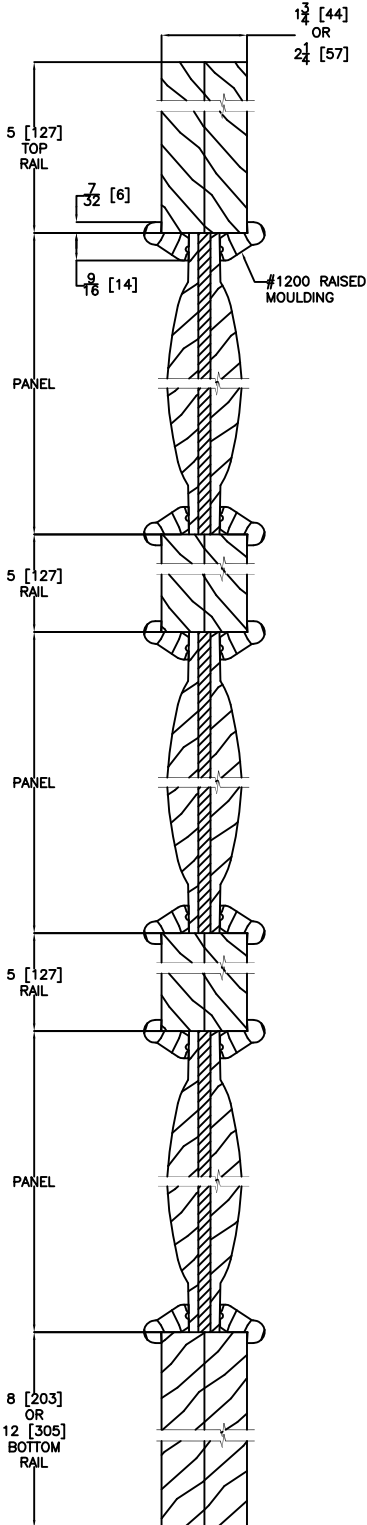

STRAP PLACEMENT (Hardware Optional/Custom Placement Available)

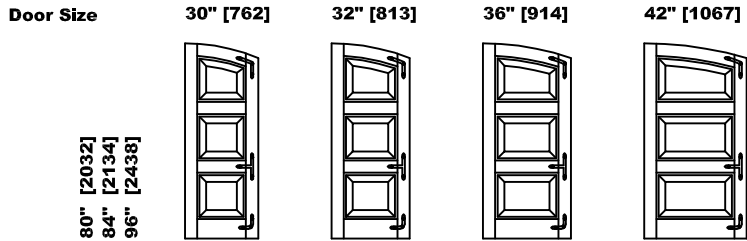

VERTICAL DOOR CROSS SECTION

ELEVATION NOTES

Door Size = Book Size Before Prefit
 Daylight Opening (DLO) = Visible Glass
 Values in brackets [] are millimeter conversions.

DOOR CROSS-SECTION

Moulding Profile = 1200
 Panel Profile = Convex Long
 See 1223 Cross Section sheet for more detail.

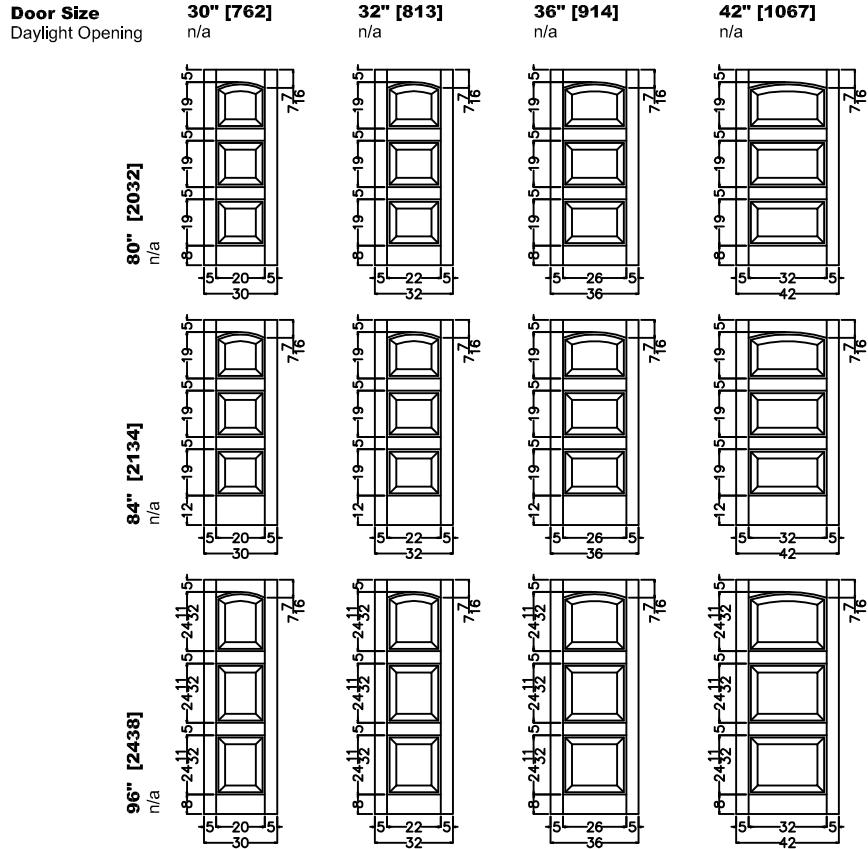
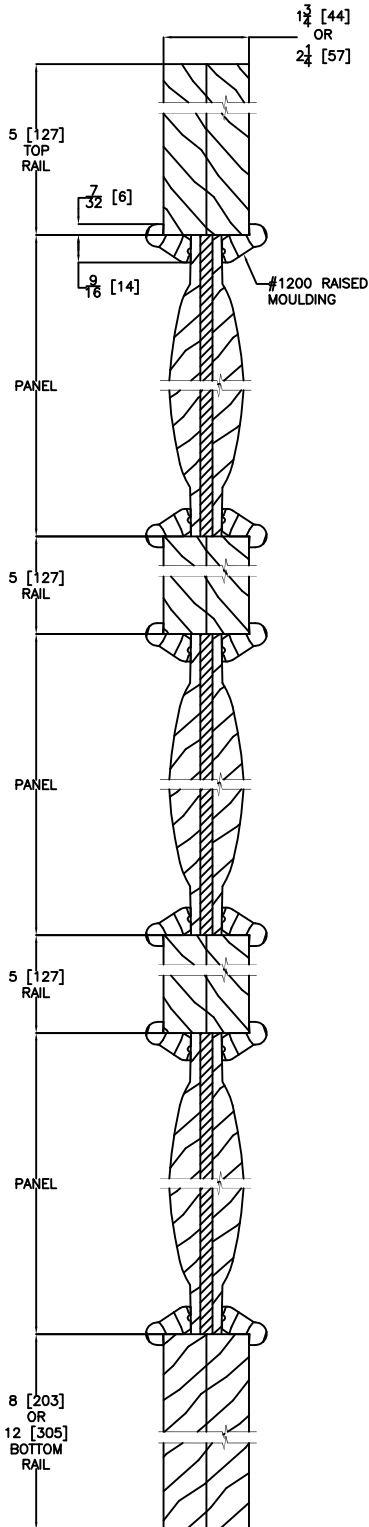

STRAP PLACEMENT (Hardware Optional/Custom Placement Available)

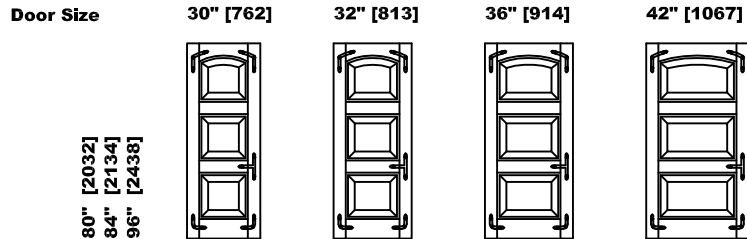

VERTICAL DOOR CROSS SECTION

ELEVATION NOTES

Door Size = Book Size Before Prefit
 Daylight Opening (DLO) = Visible Glass
 Values in brackets [] are millimeter conversions.

DOOR CROSS-SECTION

Moulding Profile = 1200
 Panel Profile = Convex Long
 See 1203 Cross Section sheet for more detail.

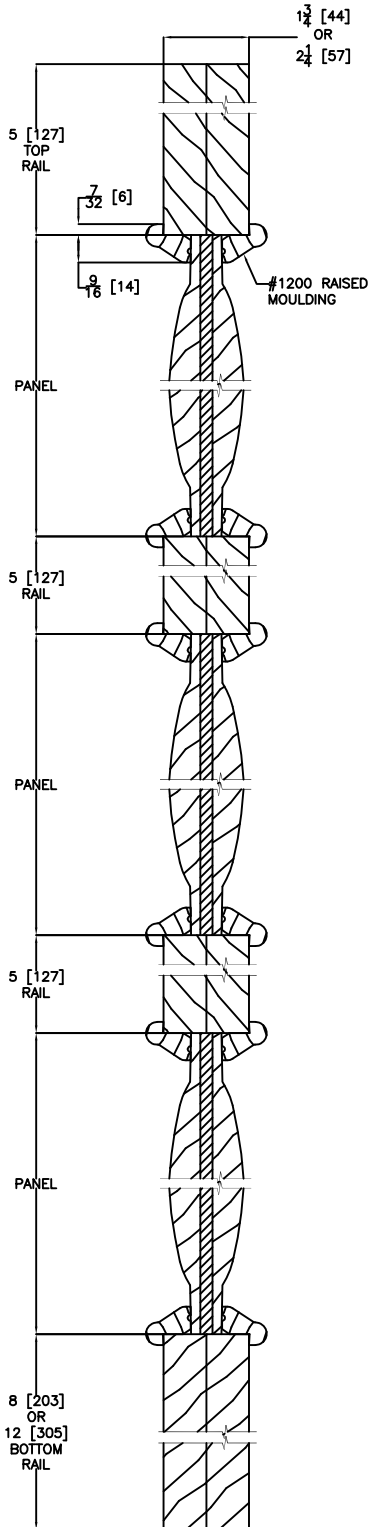

Door Size	30" [762]	32" [813]	36" [914]	42" [1067]
Daylight Opening	n/a	n/a	n/a	n/a
80" [2032]				
84" [2134]				
96" [2438]				

STRAP PLACEMENT (Hardware Optional/Custom Placement Available)

Door Size	30" [762]	32" [813]	36" [914]	42" [1067]
80" [2032] 84" [2134] 96" [2438]				

VERTICAL DOOR CROSS SECTION

ELEVATION NOTES

Door Size = Book Size Before Prefit
 Daylight Opening (DLO) = Visible Glass
 Values in brackets [] are millimeter conversions.

DOOR CROSS-SECTION

Moulding Profile = 1200
 Panel Profile = Convex Long
 See 1203 Cross Section sheet for more detail.

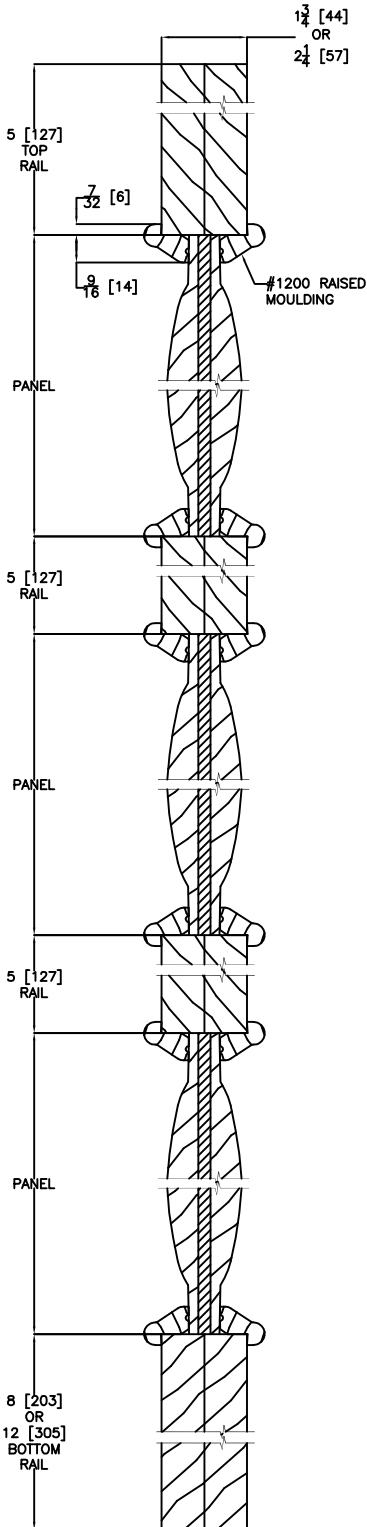

VERTICAL DOOR CROSS SECTION

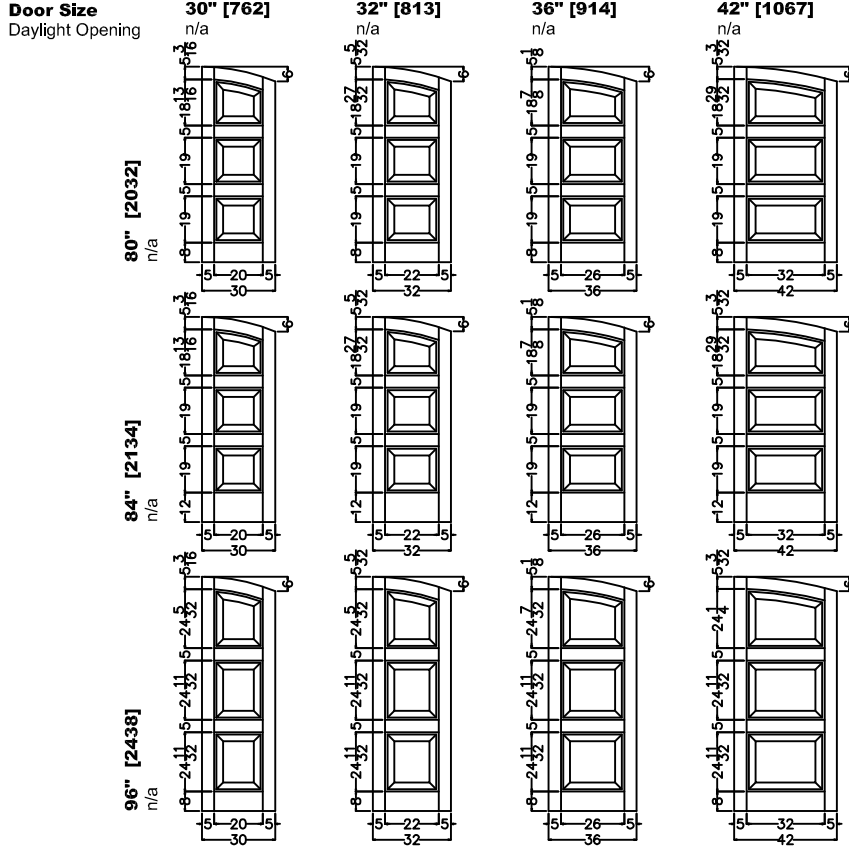

STRAP PLACEMENT (Hardware Optional/Custom Placement Available)

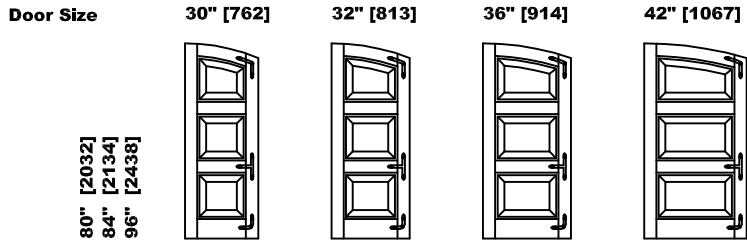

ELEVATION NOTES

Door Size = Book Size Before Prefit
 Daylight Opening (DLO) = Visible Glass
 Values in brackets [] are millimeter conversions.

DOOR CROSS-SECTION

Moulding Profile = 1200
 Panel Profile = Convex Long
 See 1223 Cross Section sheet for more detail.

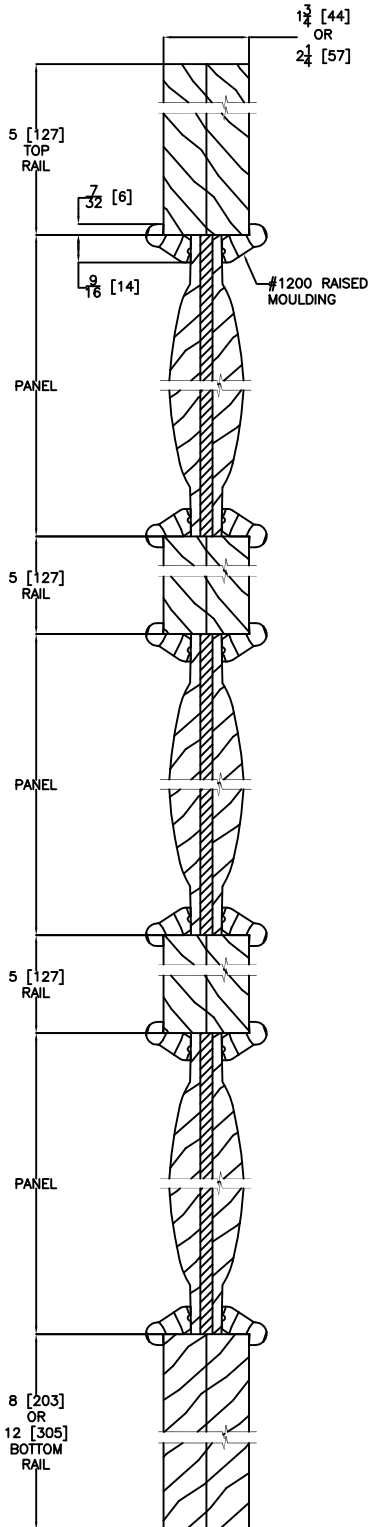

Door Size
 Daylight Opening

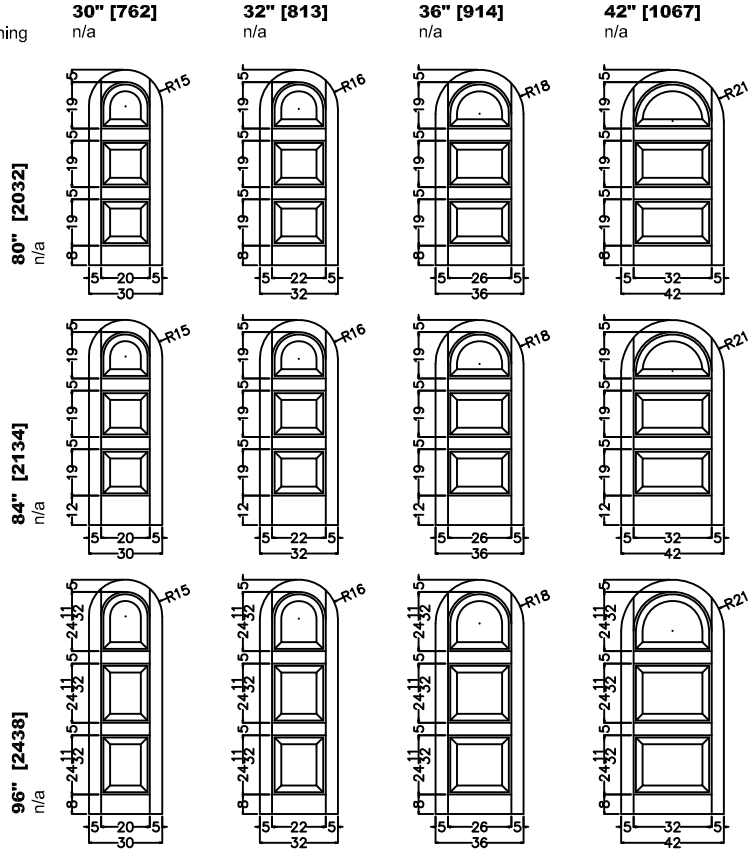

STRAP PLACEMENT

(Hardware Optional/Custom Placement Available)

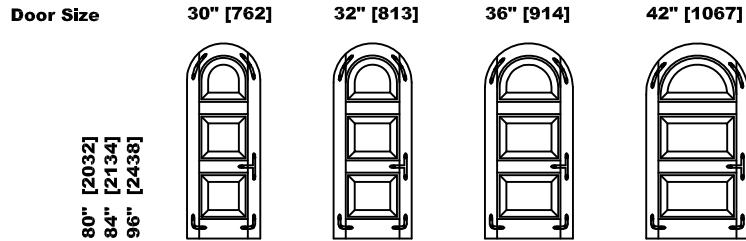

VERTICAL DOOR CROSS SECTION

ELEVATION NOTES

Door Size = Book Size Before Prefit
 Daylight Opening (DLO) = Visible Glass
 Values in brackets [] are millimeter conversions.

DOOR CROSS-SECTION

Moulding Profile = 1200
 Panel Profile = Convex Long
 See 1223 Cross Section sheet for more detail.

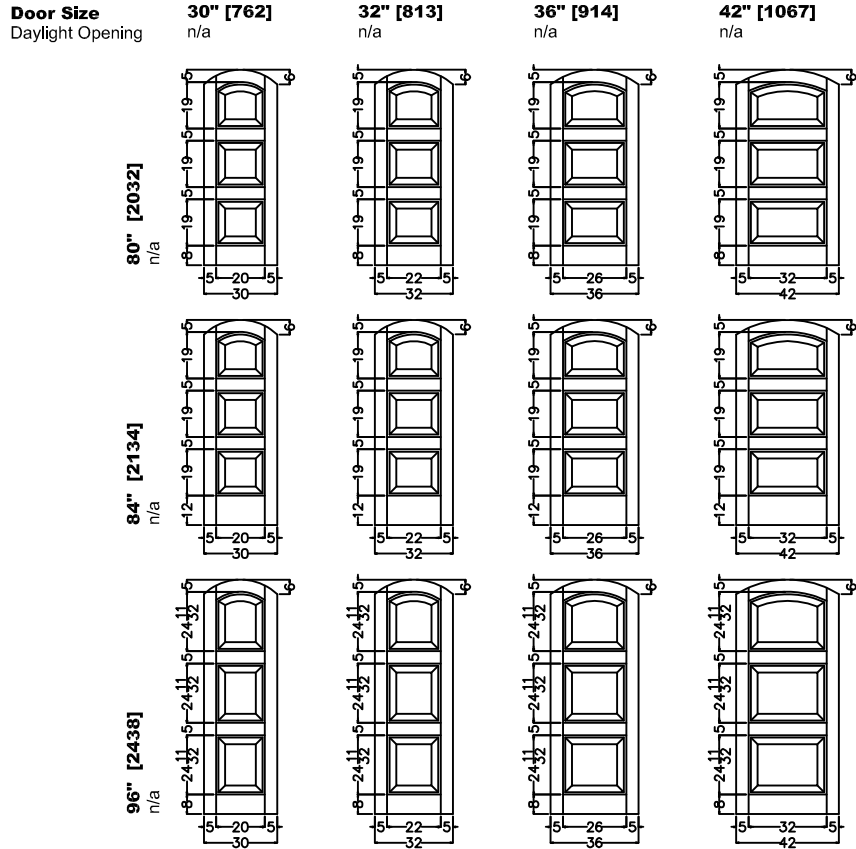
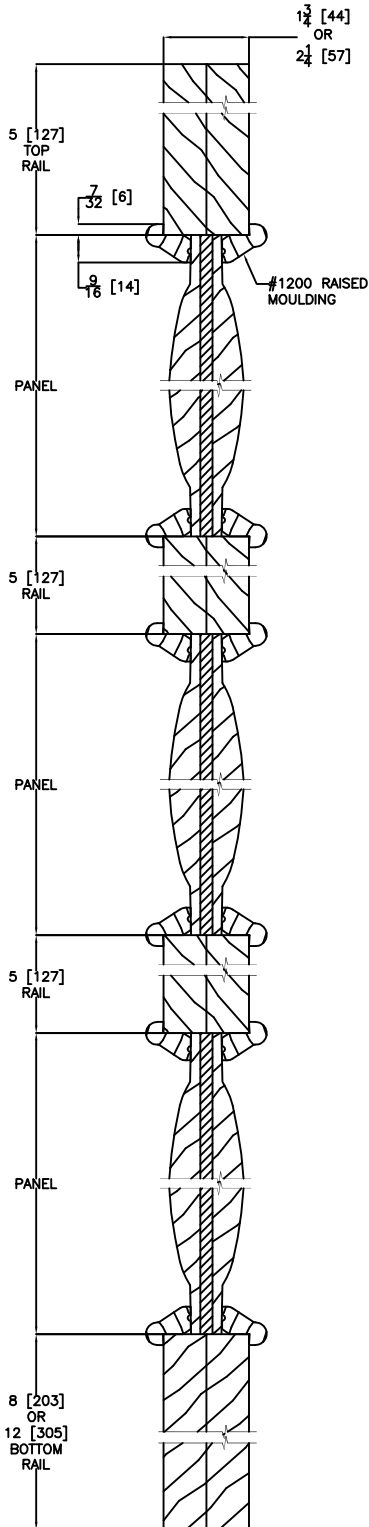

STRAP PLACEMENT (Hardware Optional/Custom Placement Available)

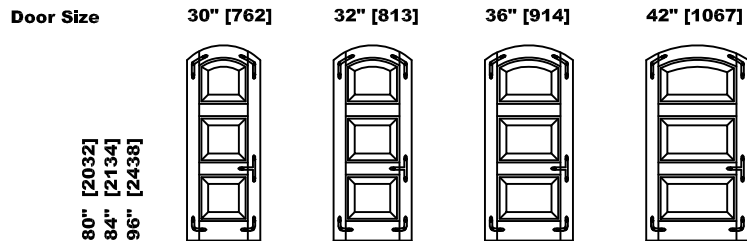

VERTICAL DOOR CROSS SECTION

ELEVATION NOTES

Door Size = Book Size Before Prefit
 Daylight Opening (DLO) = Visible Glass
 Values in brackets [] are millimeter conversions.

DOOR CROSS-SECTION

Moulding Profile = n/a
 Panel Profile = V-Groove
 See 1303 Cross Section sheet for more detail.

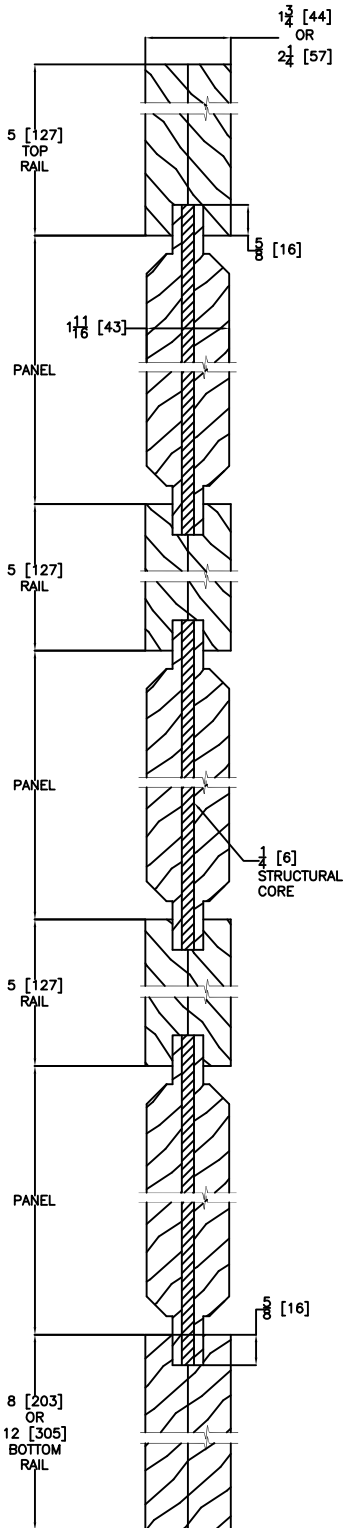

VERTICAL DOOR CROSS SECTION

Door Size	30" [762]	32" [813]	36" [914]	42" [1067]
Daylight Opening	n/a	n/a	n/a	n/a
80" [2032]				
84" [2134]				
96" [2438]				

1" CLAVOS & STRAP PLACEMENT (Hardware Optional/Custom Placement Available)

Door Size	30" [762]	32" [813]	36" [914]	42" [1067]
80" [2032] 84" [2134] 96" [2438]				

1" ROUND CLAVOS ○ ○
 OR
 1" DIAMOND CLAVOS ◆ ◆
 (Quantity & Placement Alike)

1.75" CLAVOS & STRAP PLACEMENT (Hardware Optional/Custom Placement Available)

Door Size	30" [762]	32" [813]	36" [914]	42" [1067]
80" [2032] 84" [2134] 96" [2438]				

1.75" ROUND CLAVOS ○
 OR
 1.75" DIAMOND CLAVOS ◆
 (Quantity & Placement Alike)

ELEVATION NOTES

Door Size = Book Size Before Prefit
 Daylight Opening (DLO) = Visible Glass
 Values in brackets [] are millimeter conversions.

DOOR CROSS-SECTION

Moulding Profile = n/a
 Panel Profile = V-Groove
 See 1303 Cross Section sheet for more detail.

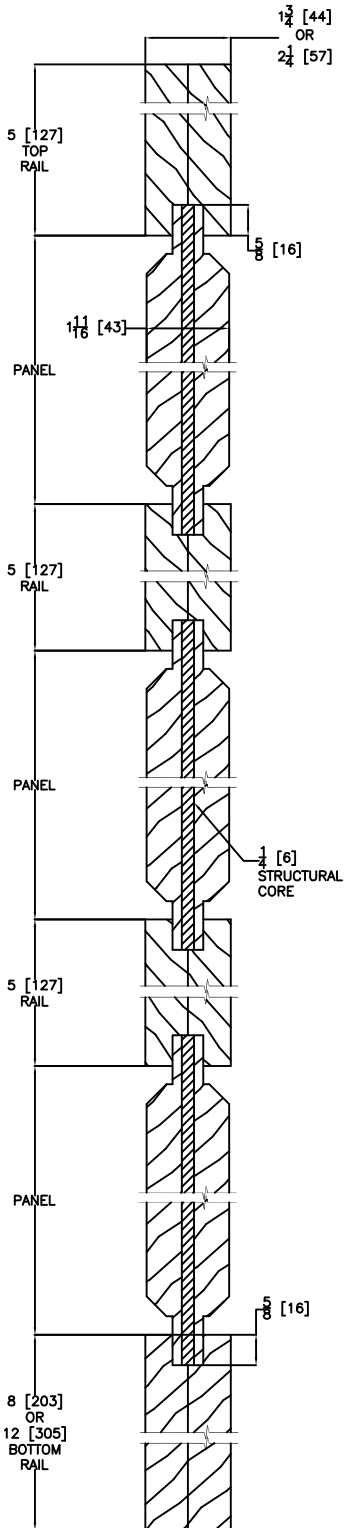

VERTICAL DOOR CROSS SECTION

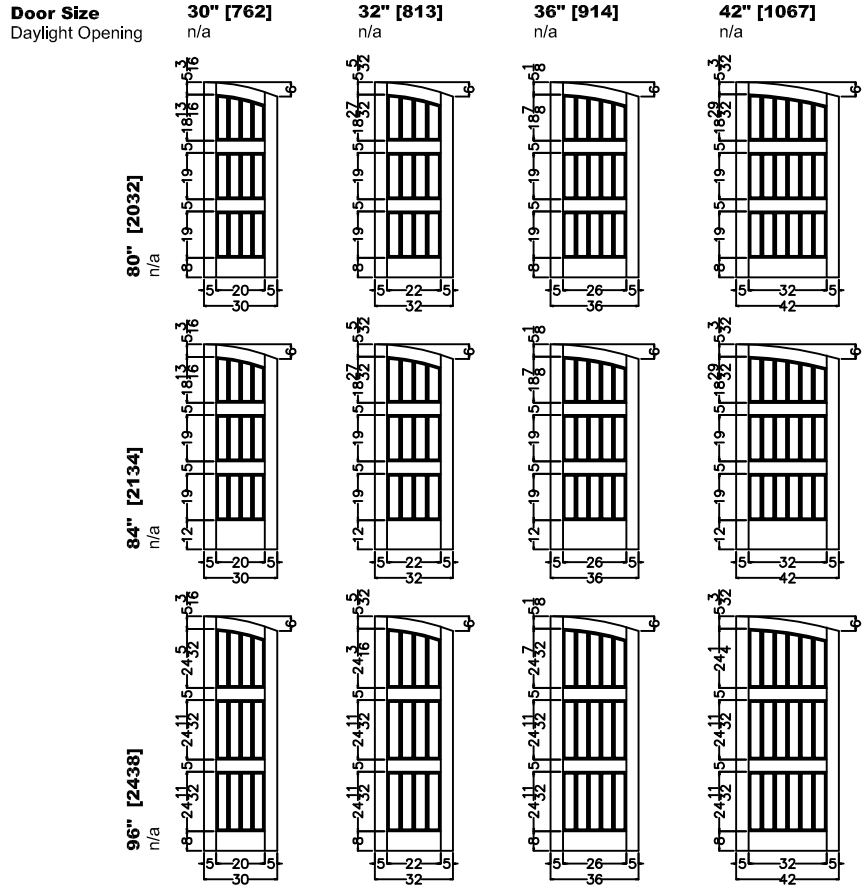

1" CLAVOS & STRAP PLACEMENT (Hardware Optional/Custom Placement Available)

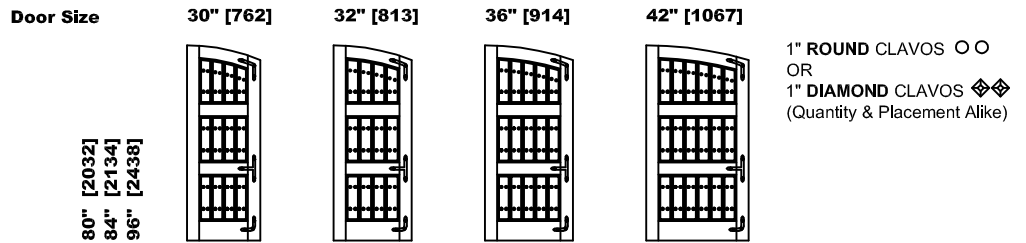

1.75" CLAVOS & STRAP PLACEMENT (Hardware Optional/Custom Placement Available)

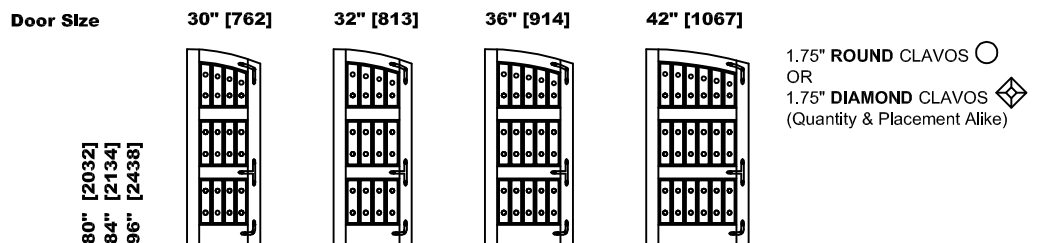

ELEVATION NOTES

Door Size = Book Size Before Prefit
 Daylight Opening (DLO) = Visible Glass
 Values in brackets [] are millimeter conversions.

DOOR CROSS-SECTION

Moulding Profile = n/a
 Panel Profile = V-Groove
 See 1303 Cross Section sheet for more detail.

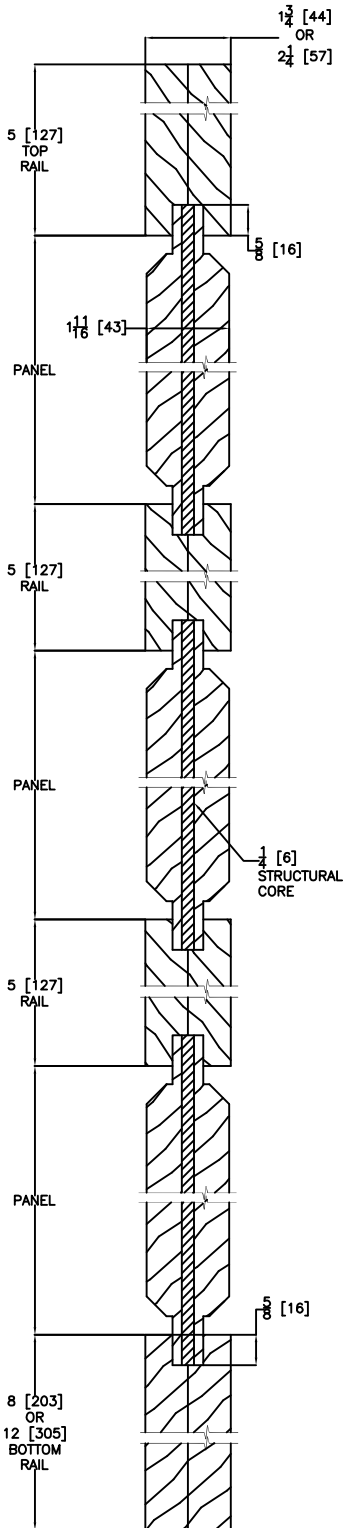

VERTICAL DOOR CROSS SECTION

Door Size
 Daylight Opening

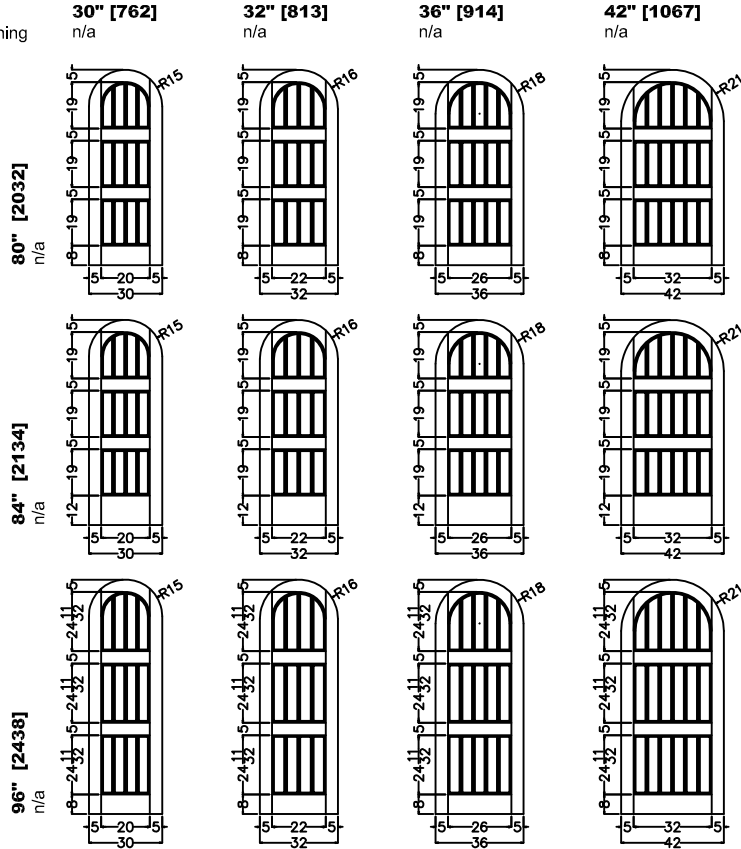

1" CLAVOS & STRAP PLACEMENT (Hardware Optional/Custom Placement Available)

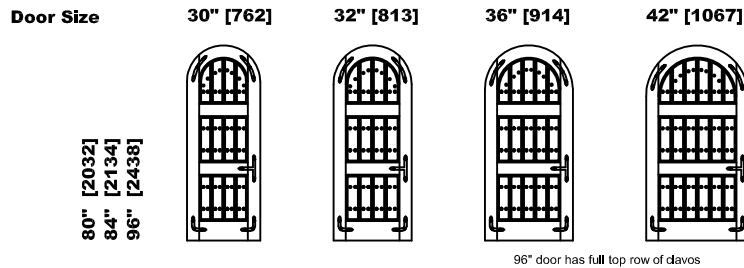

1" ROUND CLAVOS ○ ○
 OR
 1" DIAMOND CLAVOS ◆ ◆
 (Quantity & Placement Alike)

1.75" CLAVOS & STRAP PLACEMENT (Hardware Optional/Custom Placement Available)

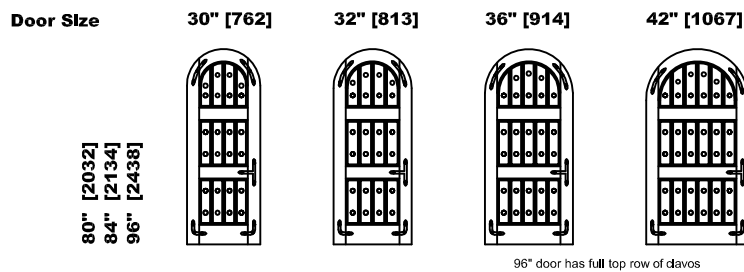

1.75" ROUND CLAVOS ○
 OR
 1.75" DIAMOND CLAVOS ◆
 (Quantity & Placement Alike)

ELEVATION NOTES

Door Size = Book Size Before Prefit
 Daylight Opening (DLO) = Visible Glass
 Values in brackets [] are millimeter conversions.

DOOR CROSS-SECTION

Moulding Profile = n/a
 Panel Profile = V-Groove
 See 1303 Cross Section sheet for more detail.

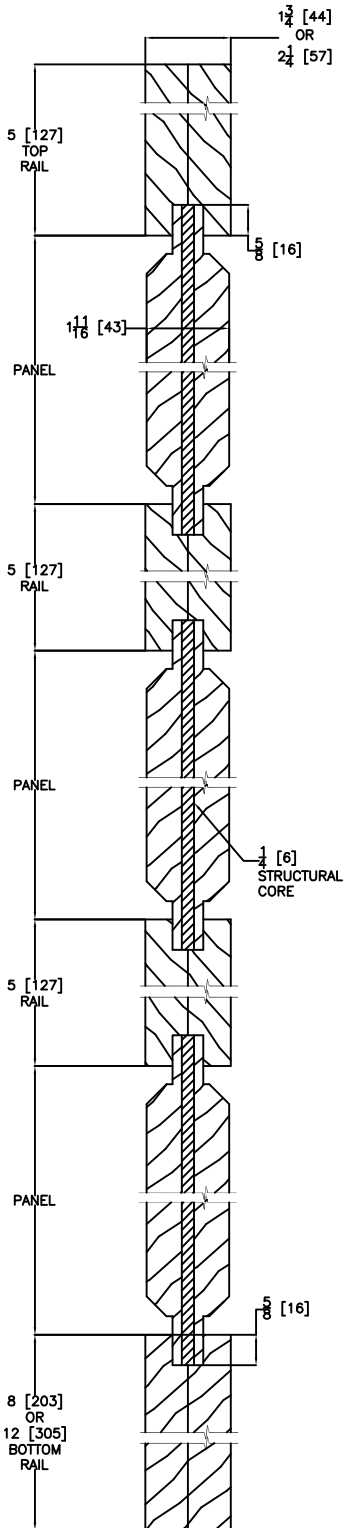

VERTICAL DOOR CROSS SECTION

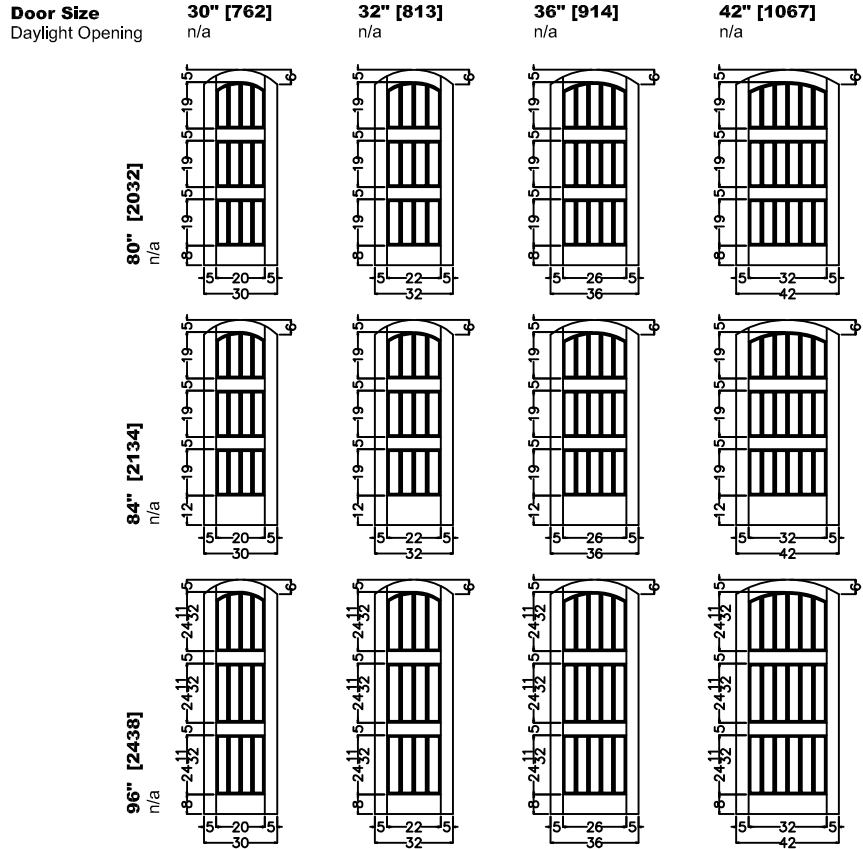

1" CLAVOS & STRAP PLACEMENT (Hardware Optional/Custom Placement Available)

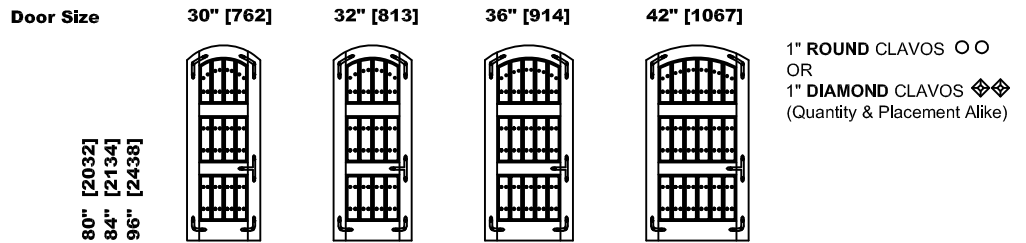

1.75" CLAVOS & STRAP PLACEMENT (Hardware Optional/Custom Placement Available)

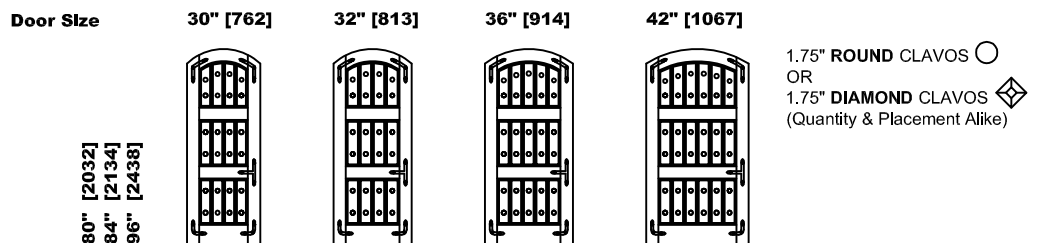

ELEVATION NOTES

Door Size = Book Size Before Prefit
 Daylight Opening (DLO) = Visible Glass
 Values in brackets [] are millimeter conversions.

DOOR CROSS-SECTION

Moulding Profile = n/a
 Panel Profile = V-Groove
 See 1323 Cross Section sheet for more detail.

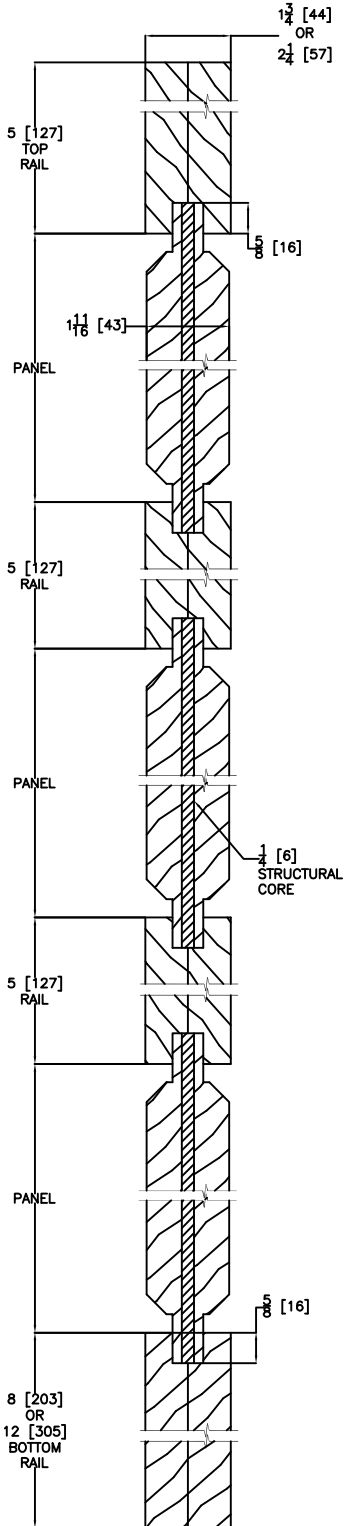

VERTICAL DOOR CROSS SECTION

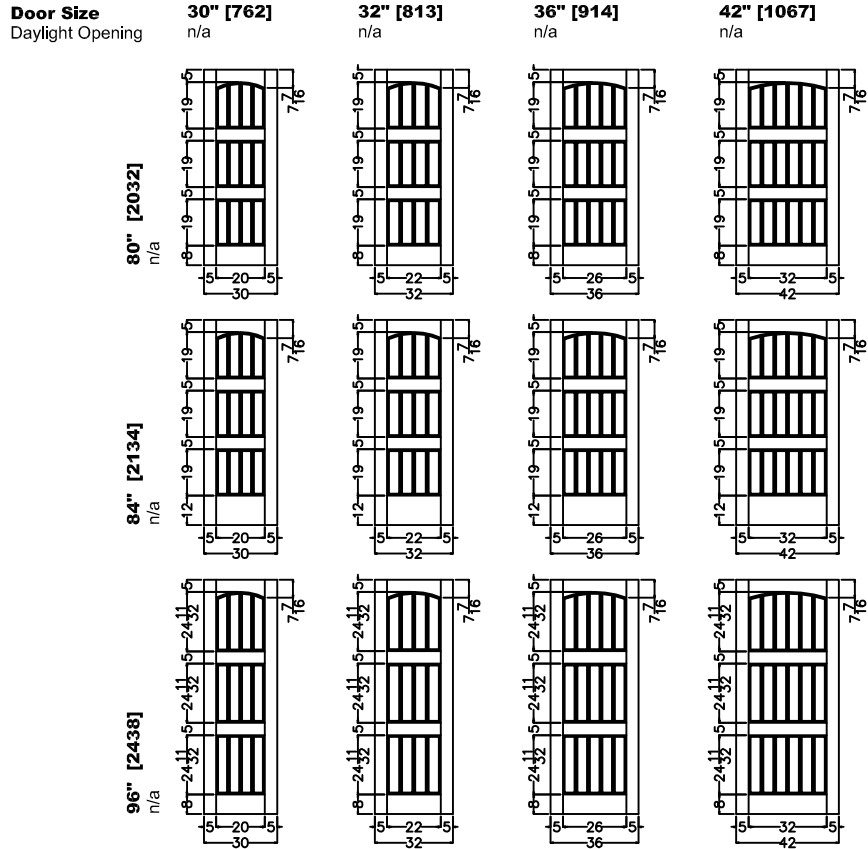

1" CLAVOS & STRAP PLACEMENT (Hardware Optional/Custom Placement Available)

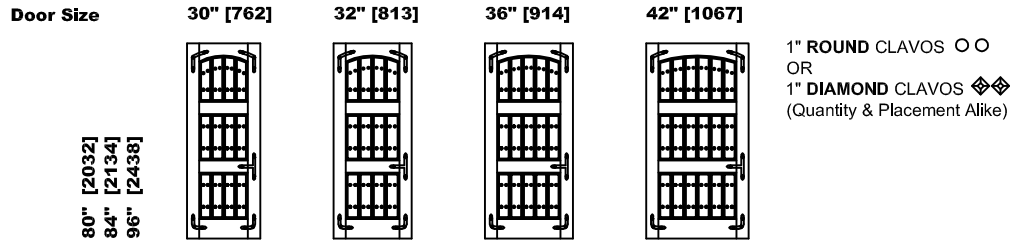

1.75" CLAVOS & STRAP PLACEMENT (Hardware Optional/Custom Placement Available)

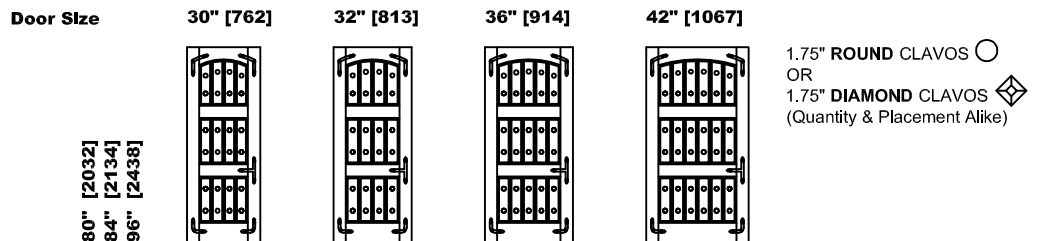

ELEVATION NOTES

Door Size = Book Size Before Prefit
 Daylight Opening (DLO) = Visible Glass
 Values in brackets [] are millimeter conversions.

DOOR CROSS-SECTION

Moulding Profile = n/a
 Panel Profile = V-Groove
 See 1323 Cross Section sheet for more detail.

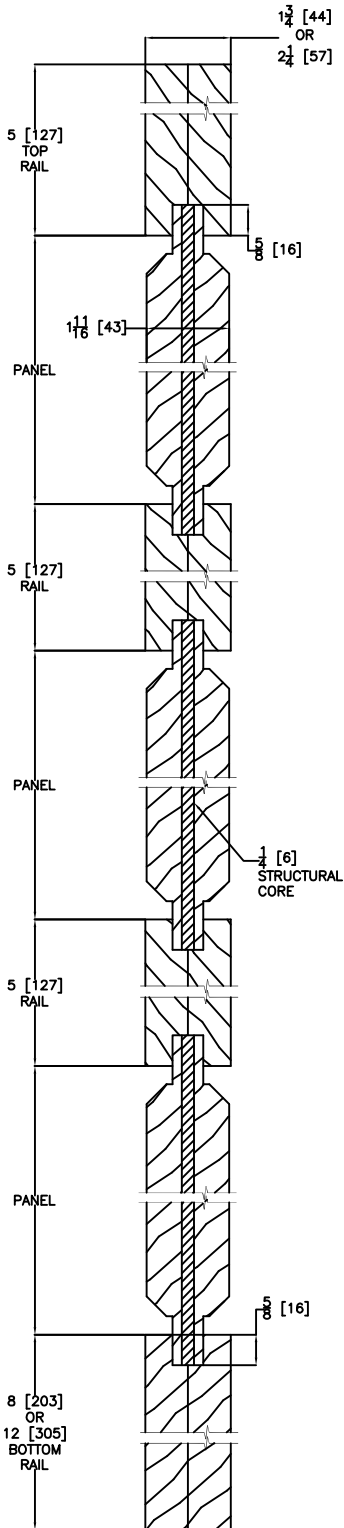

VERTICAL DOOR CROSS SECTION

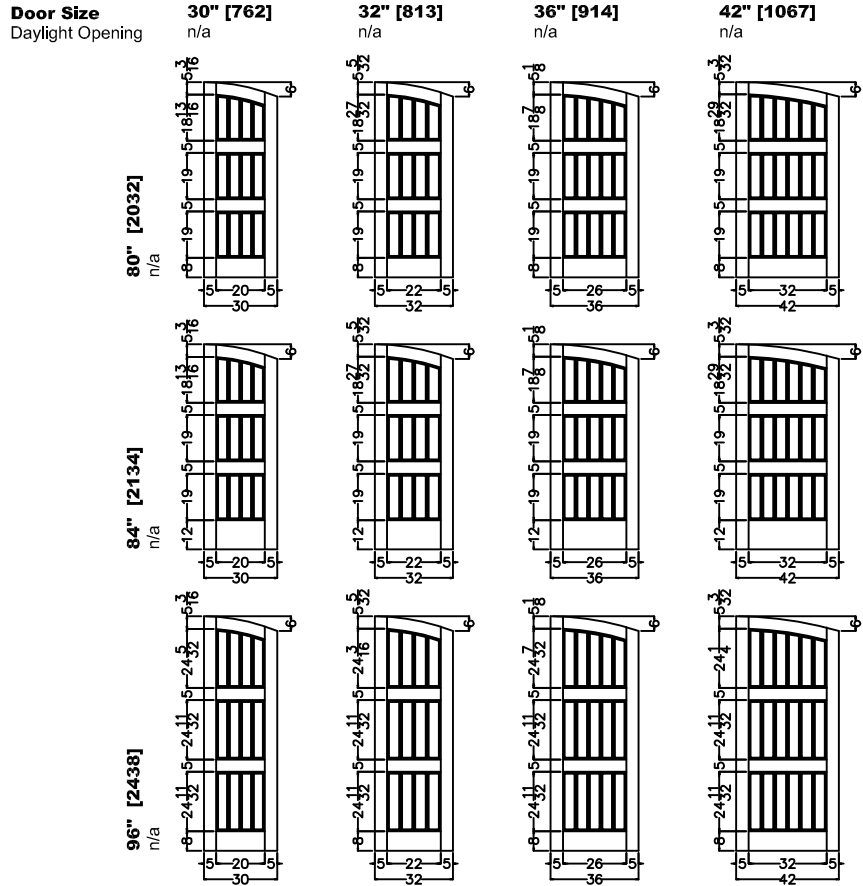

1" CLAVOS & STRAP PLACEMENT (Hardware Optional/Custom Placement Available)

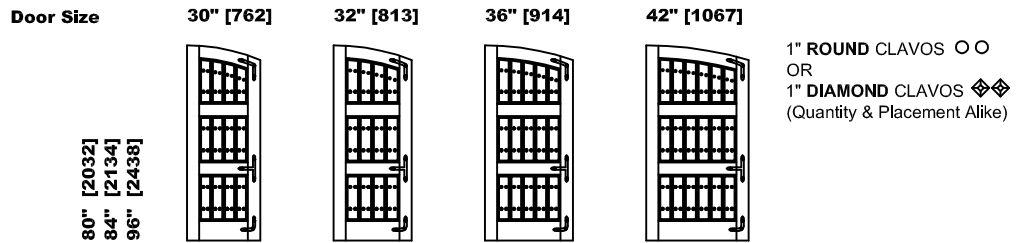

1.75" CLAVOS & STRAP PLACEMENT (Hardware Optional/Custom Placement Available)

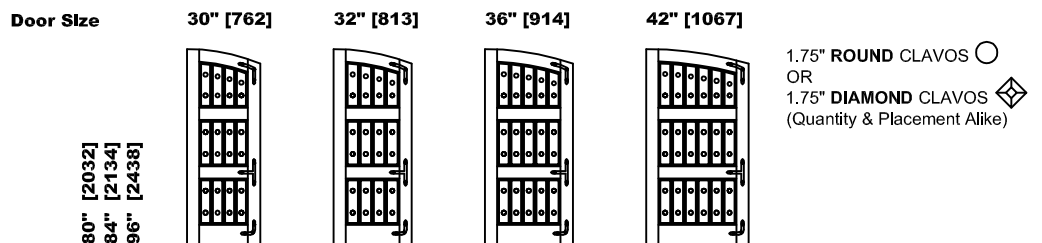

ELEVATION NOTES

Door Size = Book Size Before Prefit
 Daylight Opening (DLO) = Visible Glass
 Values in brackets [] are millimeter conversions.

DOOR CROSS-SECTION

Moulding Profile = n/a
 Panel Profile = V-Groove
 See 1323 Cross Section sheet for more detail.

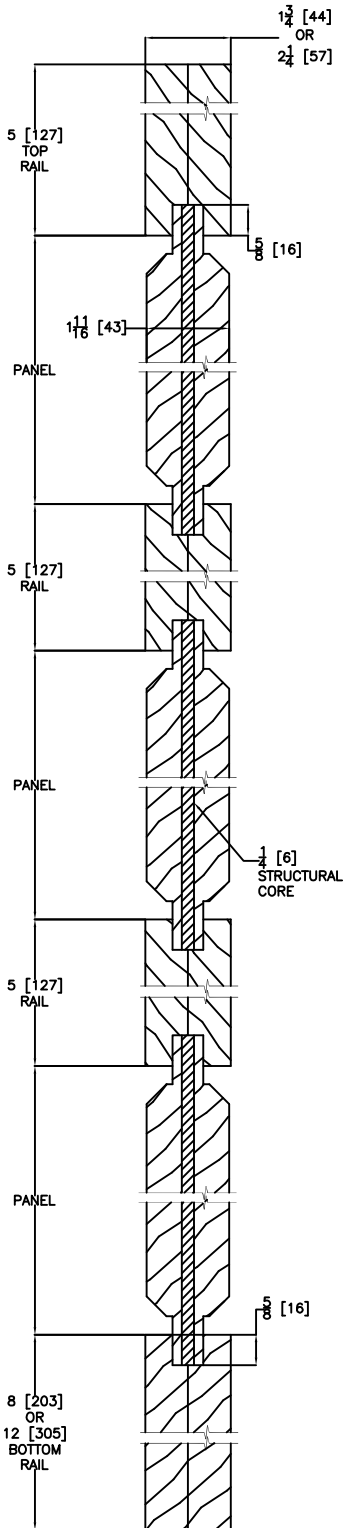

VERTICAL DOOR CROSS SECTION

Door Size
 Daylight Opening

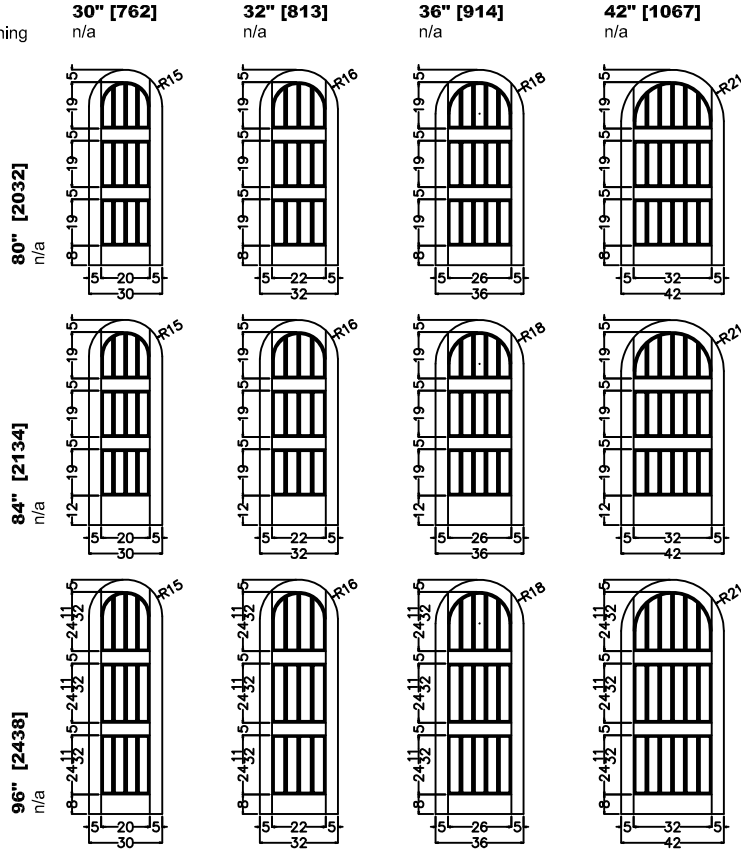

1" CLAVOS & STRAP PLACEMENT (Hardware Optional/Custom Placement Available)

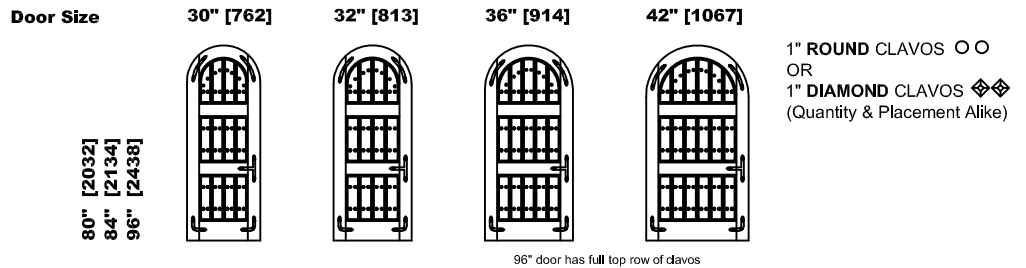

1.75" CLAVOS & STRAP PLACEMENT (Hardware Optional/Custom Placement Available)

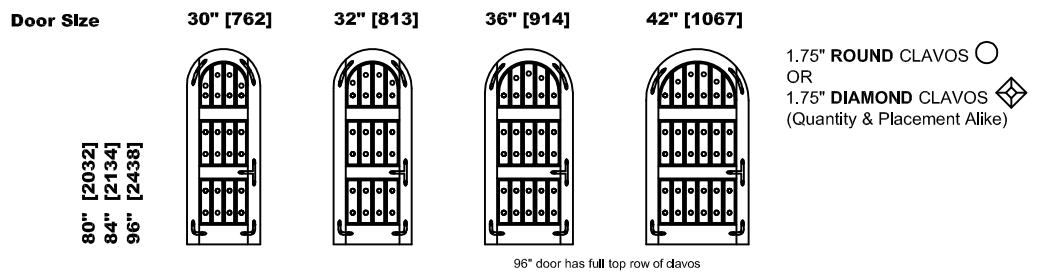

ELEVATION NOTES

Door Size = Book Size Before Prefit
 Daylight Opening (DLO) = Visible Glass
 Values in brackets [] are millimeter conversions.

DOOR CROSS-SECTION

Moulding Profile = n/a
 Panel Profile = V-Groove
 See 1323 Cross Section sheet for more detail.

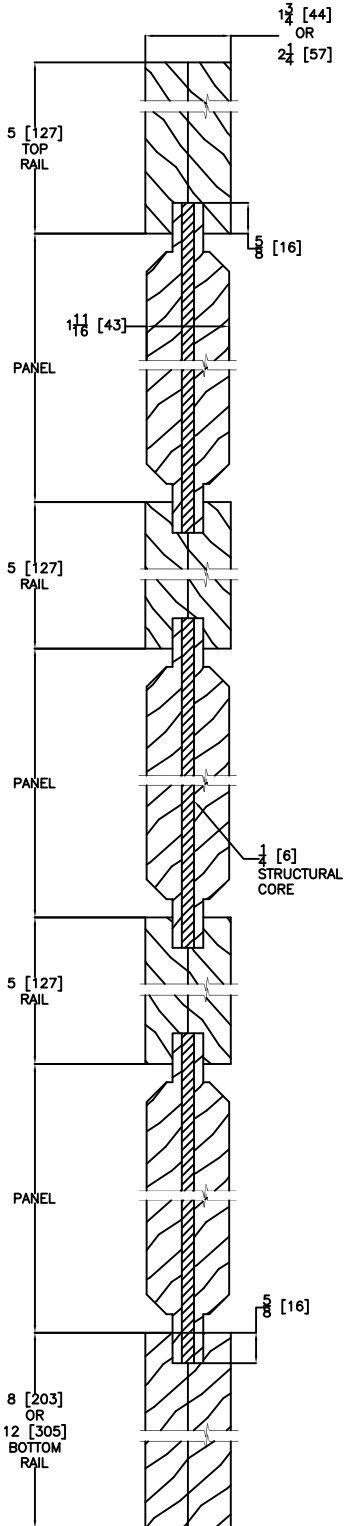

VERTICAL DOOR CROSS SECTION

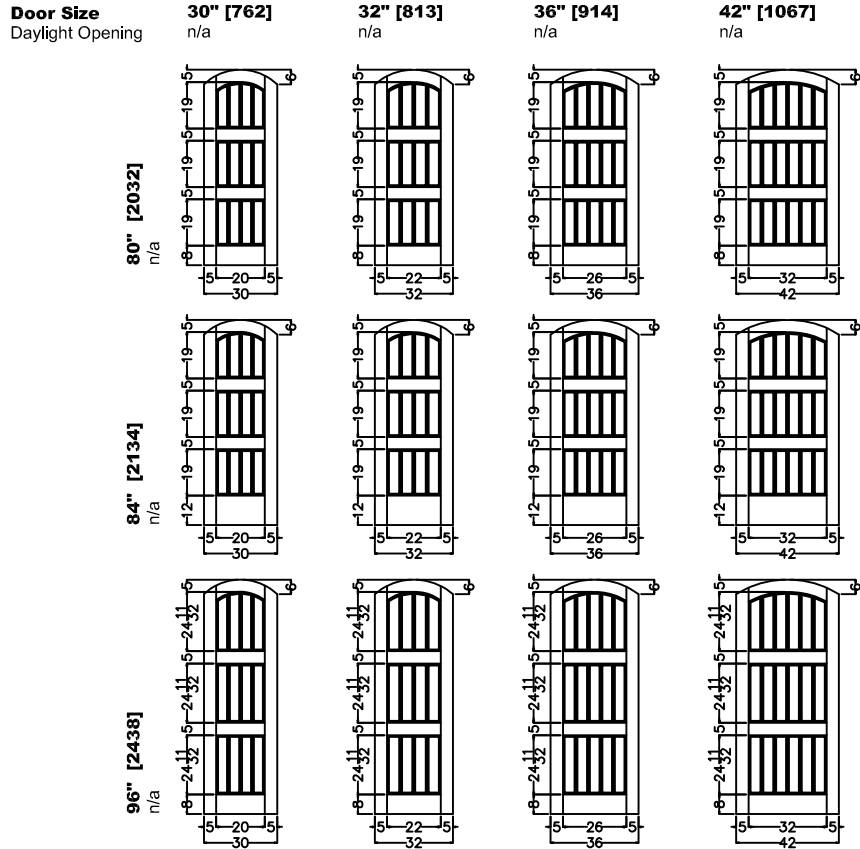

1" CLAVOS & STRAP PLACEMENT (Hardware Optional/Custom Placement Available)

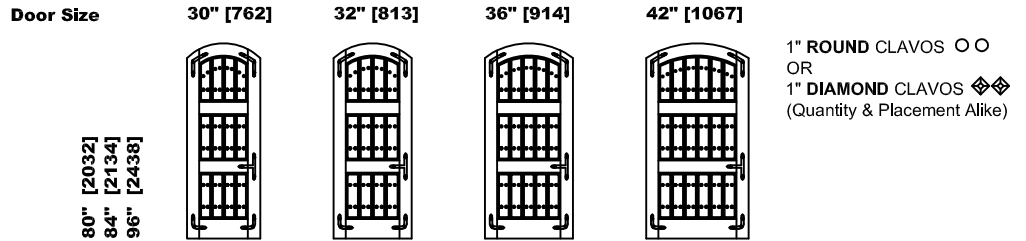

1.75" CLAVOS & STRAP PLACEMENT (Hardware Optional/Custom Placement Available)

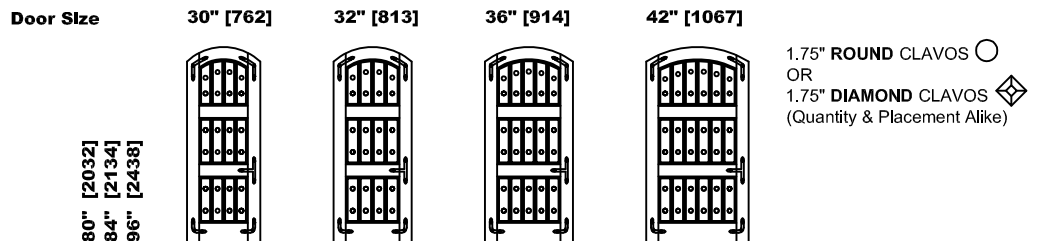

ELEVATION NOTES

Door Size = Book Size Before Prefit
 Daylight Opening (DLO) = Visible Glass
 Values in brackets [] are millimeter conversions.

DOOR CROSS-SECTION

Moulding Profile = Ovolo Sticking
 Panel Profile = Double Hip
 See 3040 Cross Section sheet for more detail.

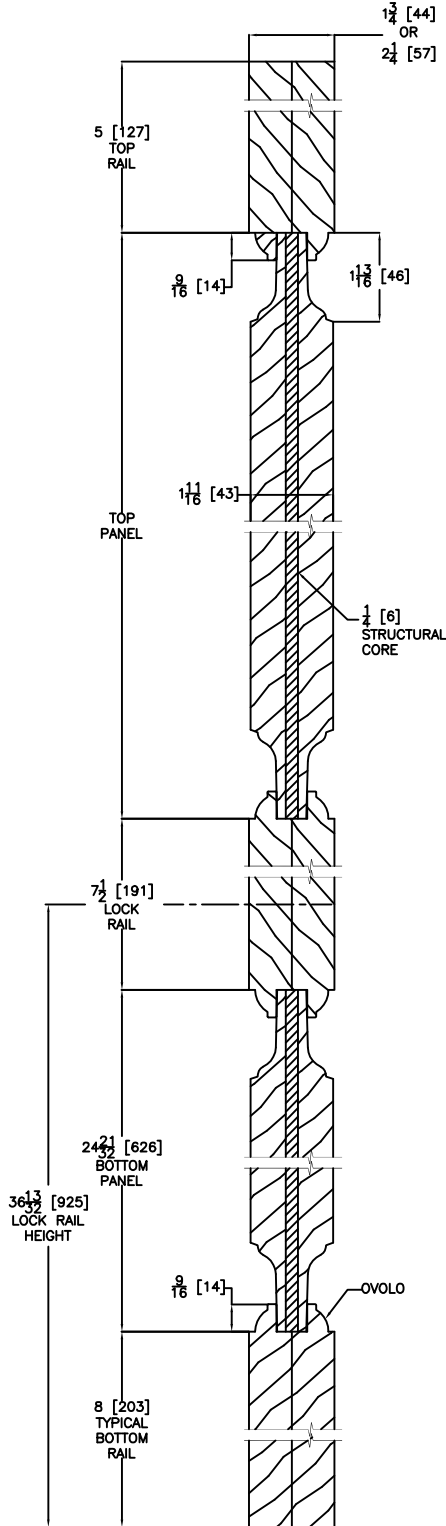

VERTICAL DOOR CROSS SECTION

Door Size
 Daylight Opening

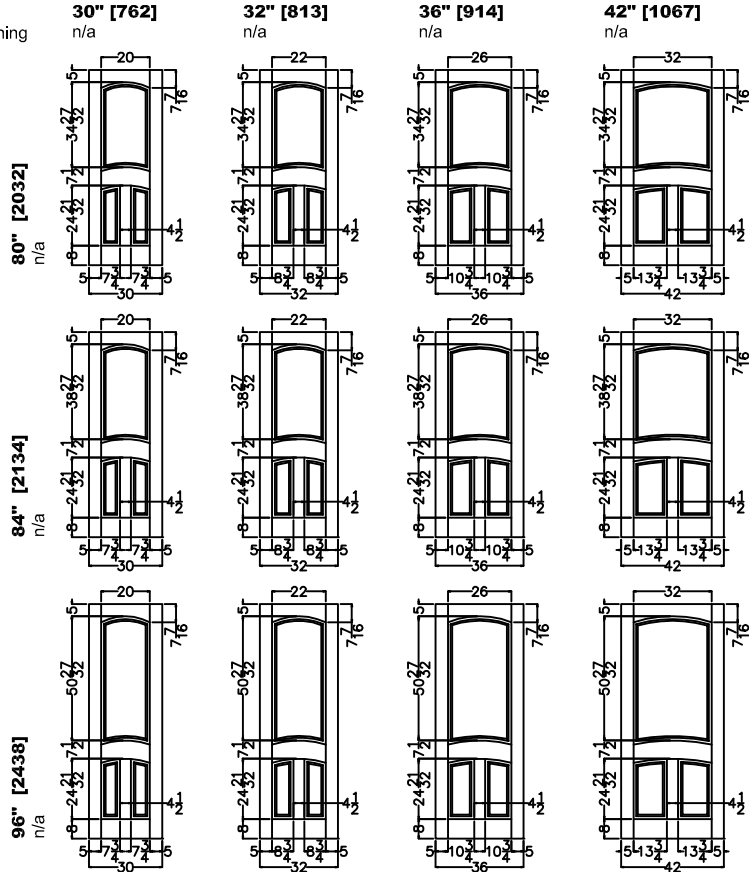

ELEVATION NOTES

Door Size = Book Size Before Prefit
 Daylight Opening (DLO) = Visible Glass
 Values in brackets [] are millimeter conversions.

DOOR CROSS-SECTION

Moulding Profile = Ovolo Sticking
 Panel Profile = Double Hip
 See 3040 Cross Section sheet for more detail.

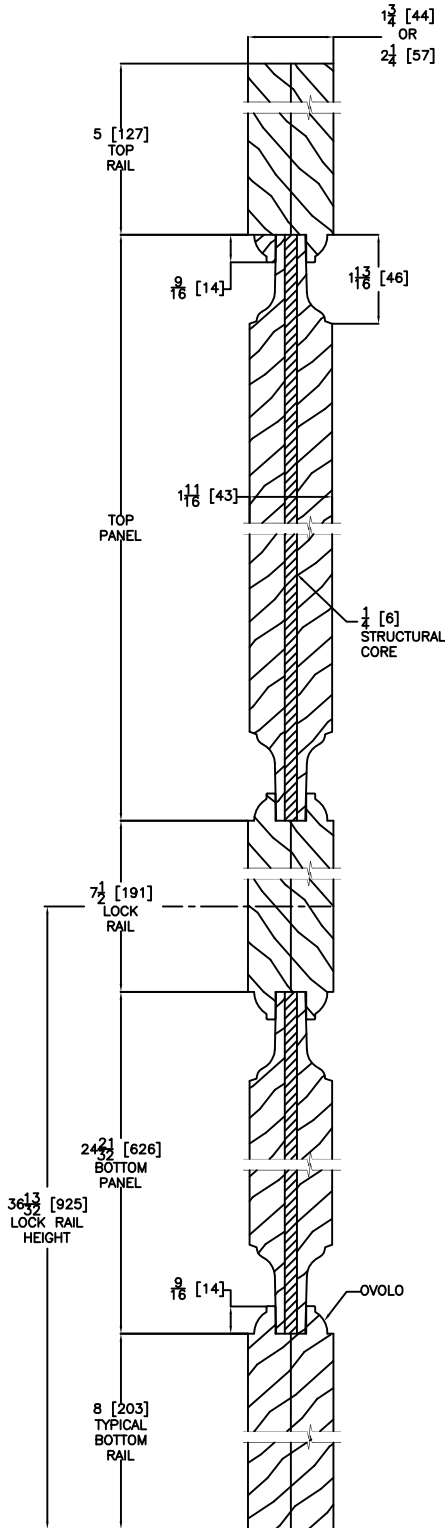

VERTICAL DOOR CROSS SECTION

RADIUS

Door Size
 Daylight Opening

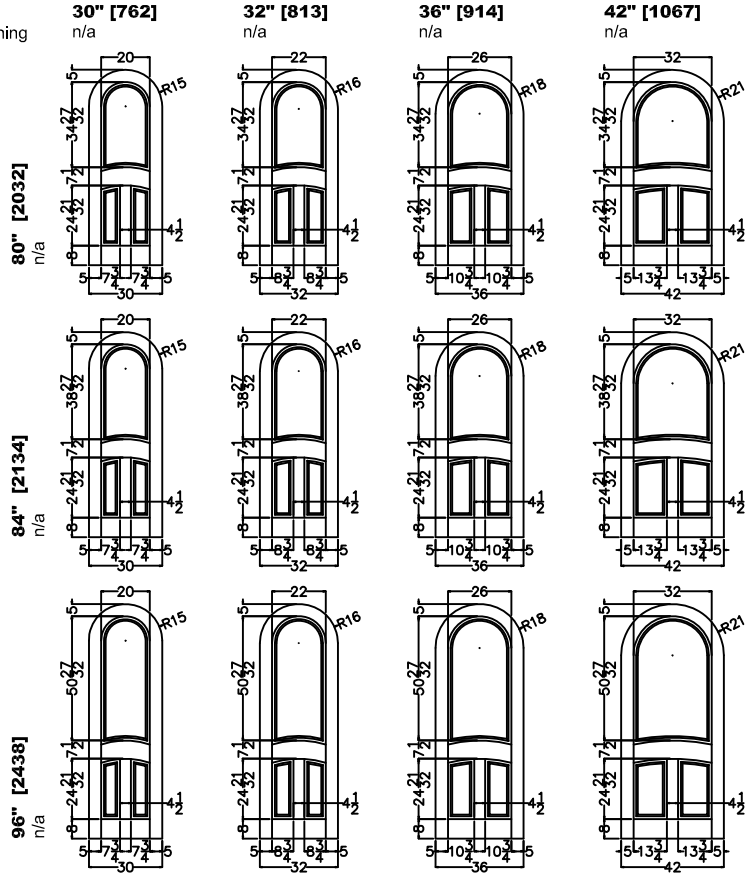

ELEVATION NOTES

Door Size = Book Size Before Prefit
 Daylight Opening (DLO) = Visible Glass
 Values in brackets [] are millimeter conversions.

DOOR CROSS-SECTION

Moulding Profile = Ovolo Sticking
 Panel Profile = Double Hip
 See 3040 Cross Section sheet for more detail.

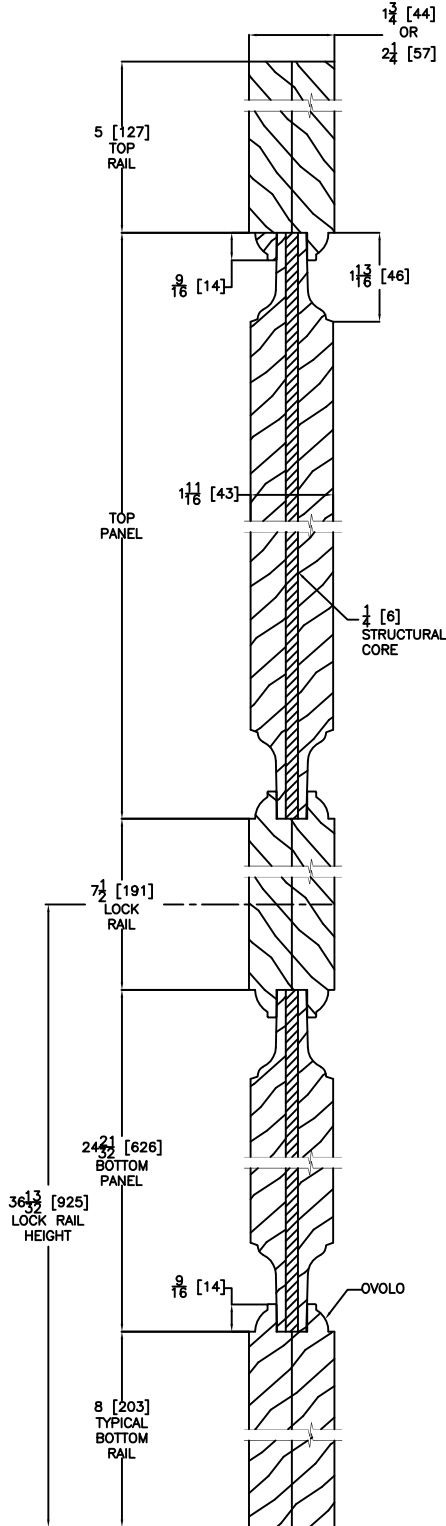

VERTICAL DOOR CROSS SECTION

SEGMENT

Door Size
 Daylight Opening

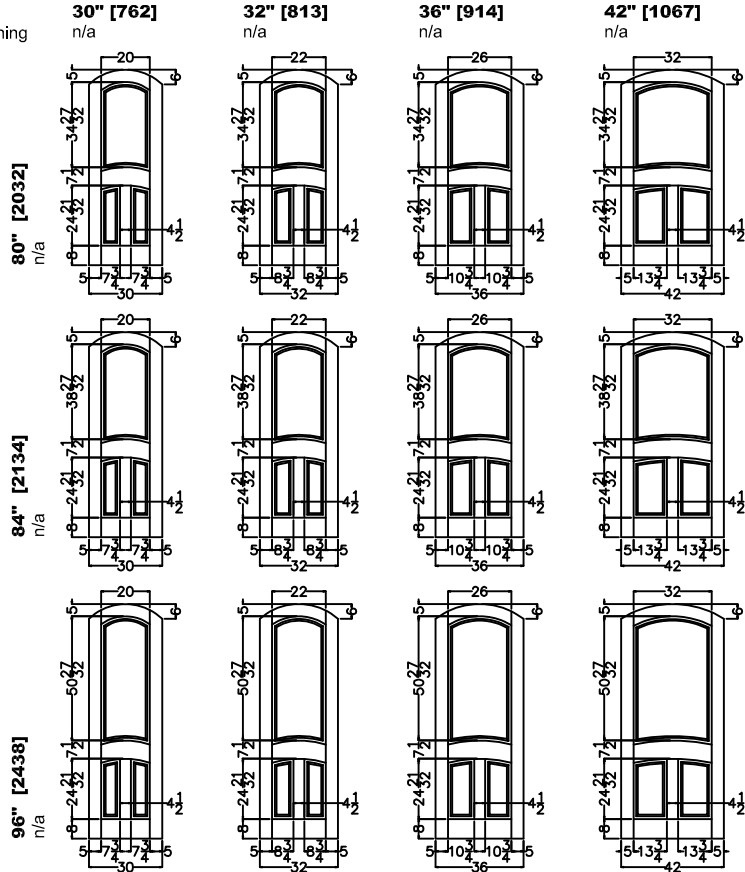

HALF SEGMENT

Door Size
 Daylight Opening

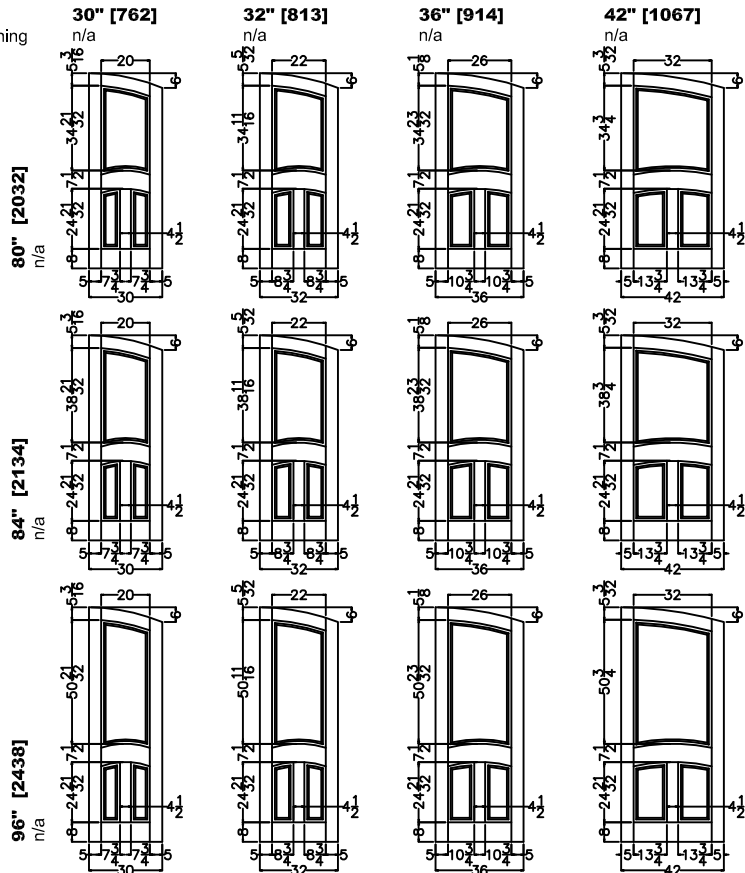

DECORATIVE ACCENTS



ROUND CLAVOS

Size Options: 1" diameter, 1.75" diameter
 Finish Options: Dark Patina, Rust Patina
 Material: Aluminum with Powder Coat Finish



DIAMOND CLAVOS

Size Options: 1", 1.75"
 Finish Options: Dark Patina, Rust Patina
 Material: Aluminum with Powder Coat Finish

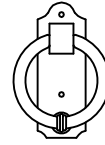

COLONIAL DOOR KNOCKER

Base: 2" Wide x 5 5/8" Tall, Handle: 4" Wide
 Finish Options: Dark Patina, Rust Patina
 Material: Iron

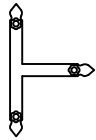

RAIL STRAP

Finish Options: Dark Patina, Rust Patina
 Material: Aluminum with Powder Coat Finish



CORNER STRAP

Finish Options: Dark Patina, Rust Patina
 Material: Aluminum with Powder Coat Finish

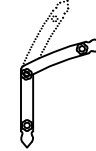

RADIUS STRAP

Finish Options: Dark Patina, Rust Patina
 Material: Aluminum with Powder Coat Finish
 Adjustable for Segment/Radius Shapes

SPEAKEASY/DOOR LIGHT

Glass Options: Clear IG, Clear SG, Bevel IG, Bevel SG, Glue Chip IG,
 Low E IG, Rain IG, Reed IG, Frosted IG, Open for Glass
 Handing: Will be Handed to Match the Door unless Otherwise Specified
 Frame Size: 11 3/4" x 14 3/4", Daylight Opening: 8" x 11", Actual Glass Size: 8 7/8" x 11 7/8"

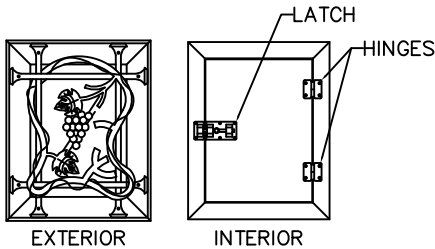

SPEAKEASY, BORDEAUX GRILLE

Hardware Finish Options: Dark Patina, Rust Patina
 Material: Wood Frame / Iron Hardware

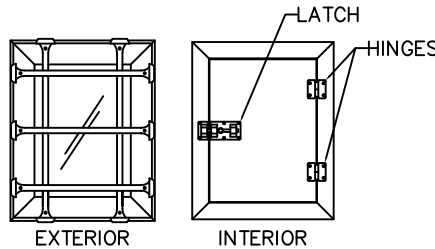

SPEAKEASY, RUSTIC GRILLE

Hardware Finish Options: Dark Patina, Rust Patina
 Material: Wood Frame / Iron Hardware

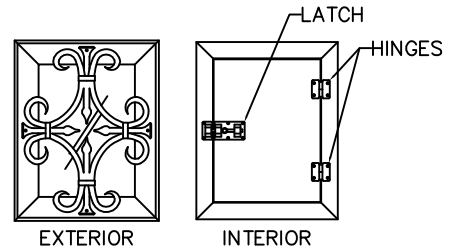

SPEAKEASY, SEVILLE GRILLE

Hardware Finish Options: Dark Patina, Rust Patina
 Material: Wood Frame / Iron Hardware

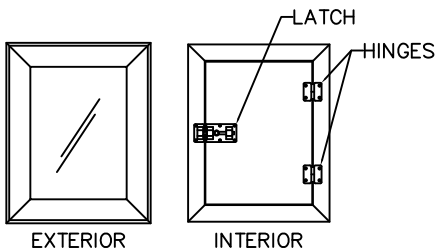

SPEAKEASY (NO GRILLE)

Hardware Finish Options: Dark Patina, Rust Patina
 Material: Wood Frame / Iron Hardware

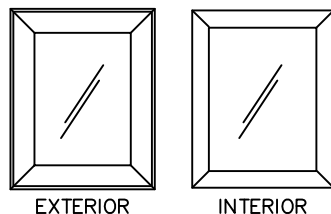

RECTANGLE DOOR LIGHT

Hardware Finish Options: n/a
 Material: Wood Frame
 Available with All Speakeasy Grilles

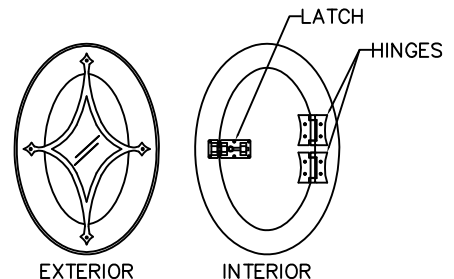

OVAL SPEAKEASY, VICTORIAN GRILLE

Hardware Finish Options: Dark Patina, Rust Patina
 Material: Wood Frame / Iron Hardware
 Frame Size: 12" x 17 1/2"



#20 CASING
2 1/4" X 1 1/8"



#20 w/ STUCCO KEY
2 1/4" X 1 1/8"



#22 CASING
2" X 1 1/8"



#13 CASING
3 1/2" X 3/4"



#14 CASING
2 1/4" X 3/4"

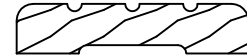

#15 CASING
3 1/2" X 3/4"



#16 CASING
2 1/4" X 3/4"



#17 CASING
4 1/2" X 1 3/16"

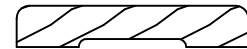

#21 CASING
3 1/2" X 5/8"



#23 CASING
3 1/2" X 1 1/8"

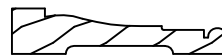

#24 CASING
3 1/4" X 11/16"

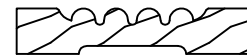

#25 CASING
3 1/2" X 11/16"

Notes:

Shown here are standard trim options.

Special size casing or custom profile casing may be available upon request.

EXTERIOR CORNER BLOCK

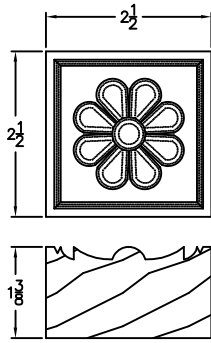

"A" BLOCK
2 1/2" X 2 1/2"

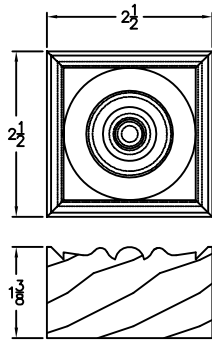

"B" BLOCK
2 1/2" X 2 1/2"

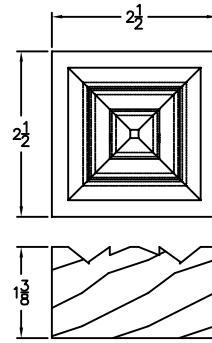

"C" BLOCK
2 1/2" X 2 1/2"

INTERIOR CORNER BLOCK

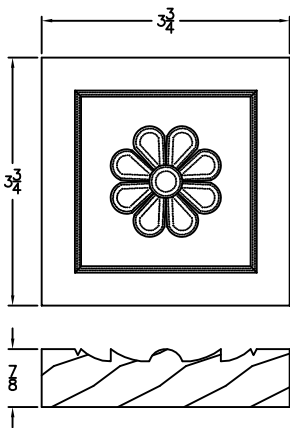

"A" BLOCK
3 3/4" X 3 3/4"

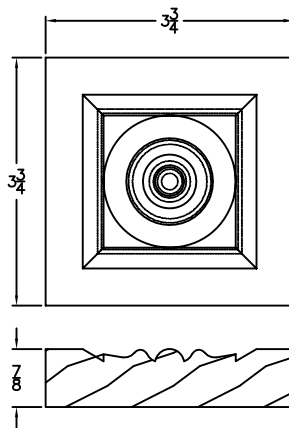

"B" BLOCK
3 3/4" X 3 3/4"

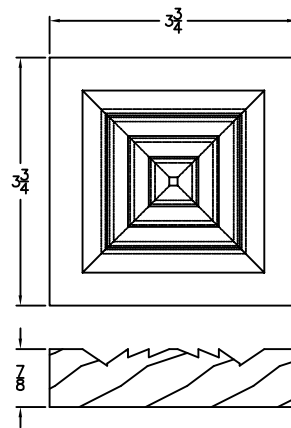

"C" BLOCK
3 3/4" X 3 3/4"

Notes:

Interior corner block may be used for exterior application and vice versa.

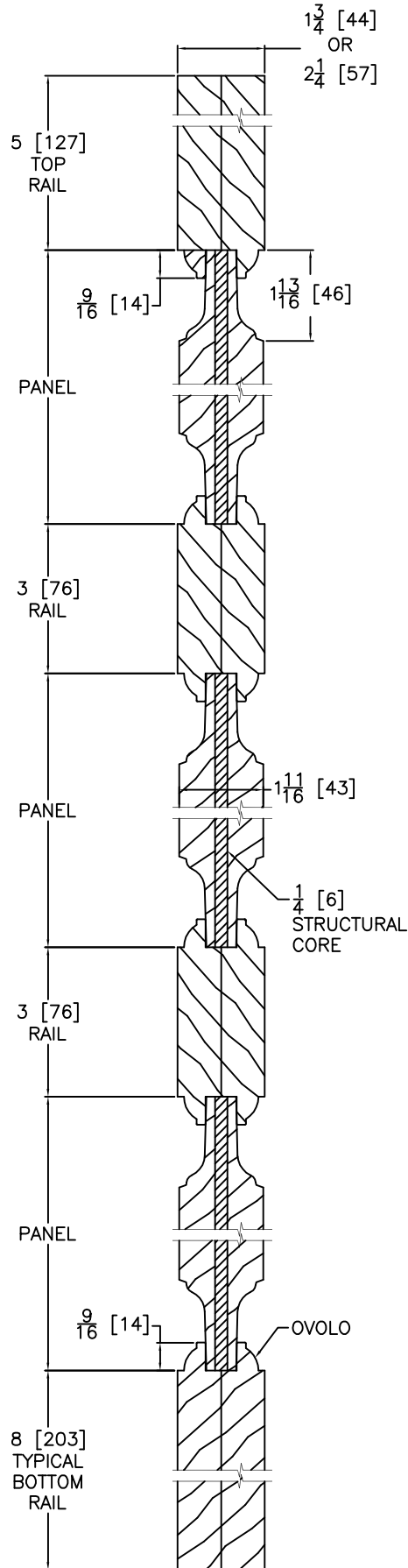
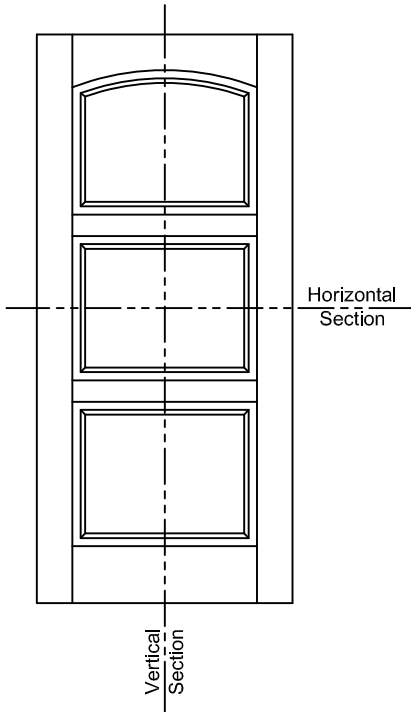
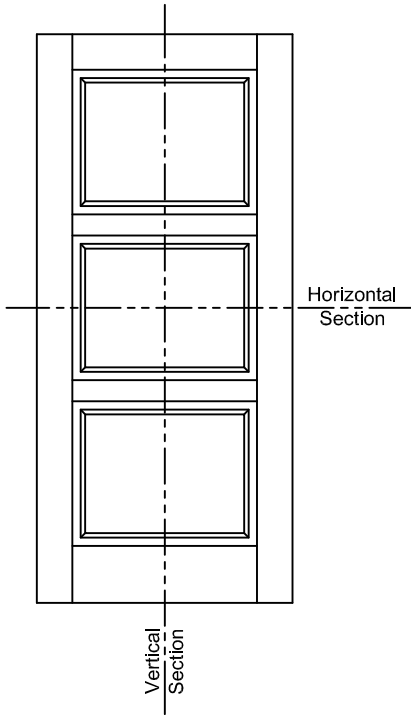

VERTICAL DOOR CROSS SECTION

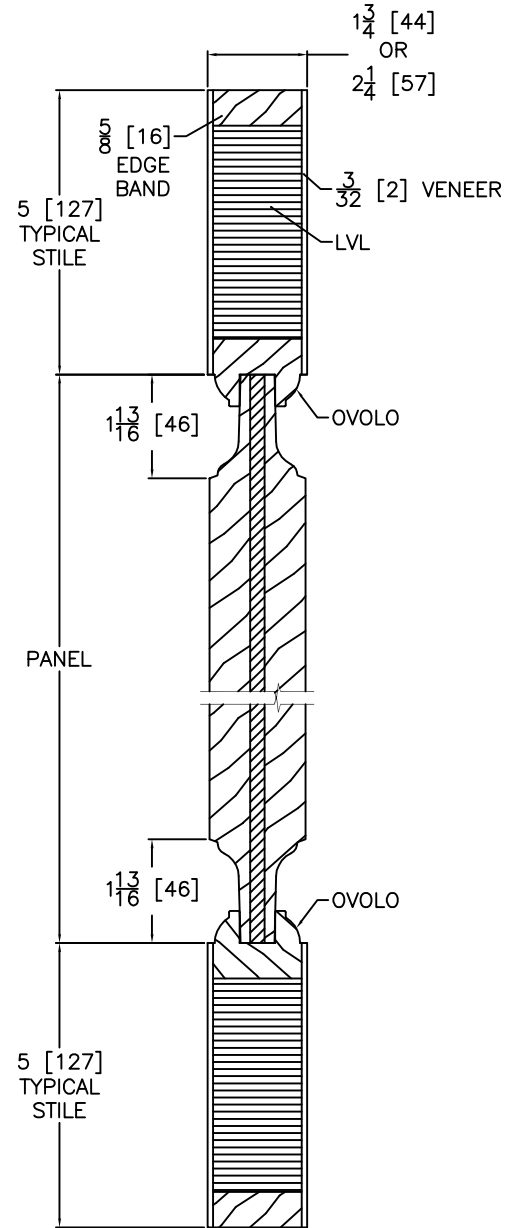

HORIZONTAL DOOR CROSS SECTION
Engineered Stile Option
(Upon Request or Doors >3'-6"X8'-0")

Notes:
Stile, Rail, Panel & Glass
vary by Size & Model of Door.
Typical Sizes are Shown.

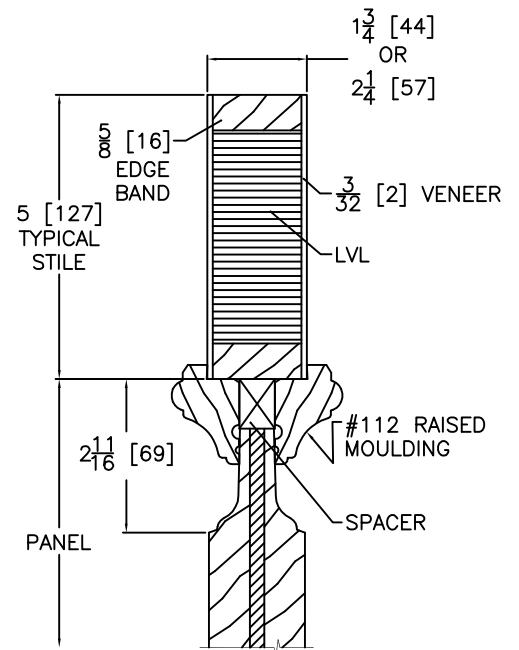
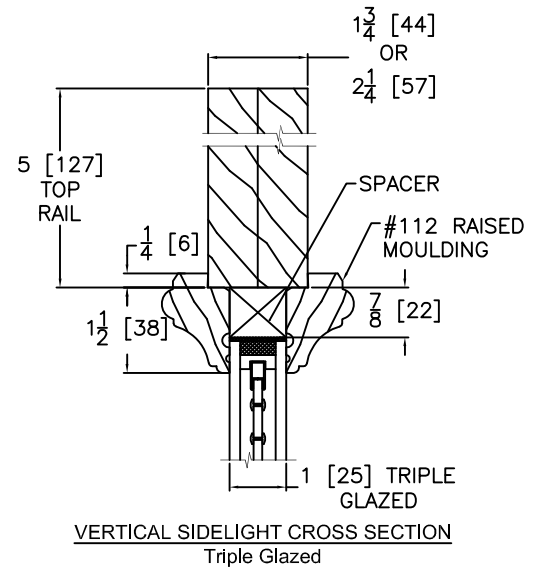
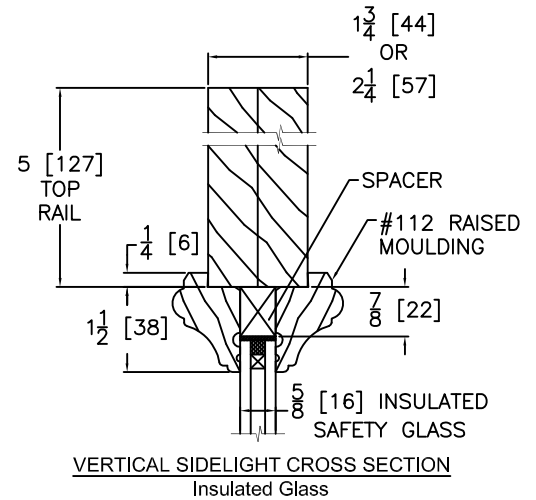
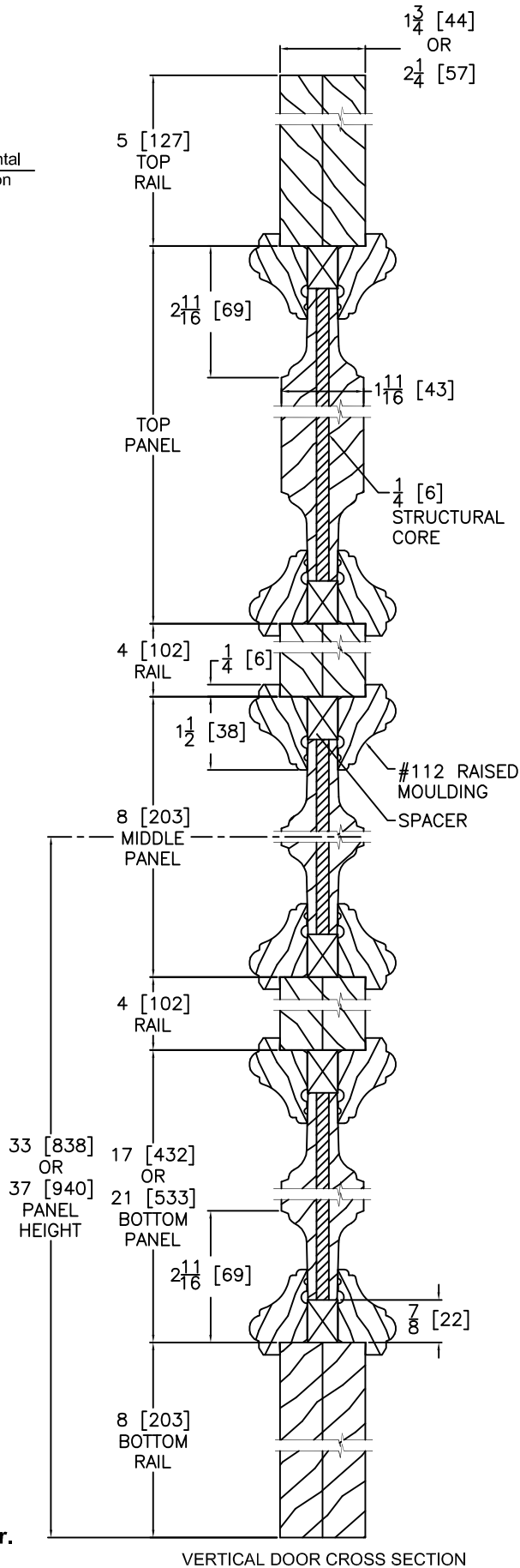
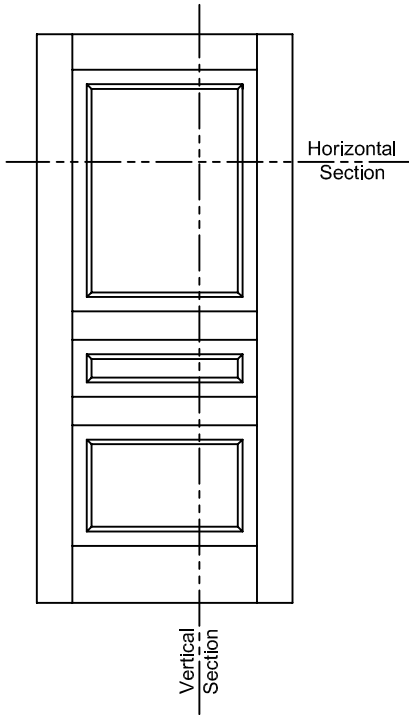

Notes:
Stile, Rail, Panel & Glass
vary by Size & Model of Door.
Typical Sizes are Shown.

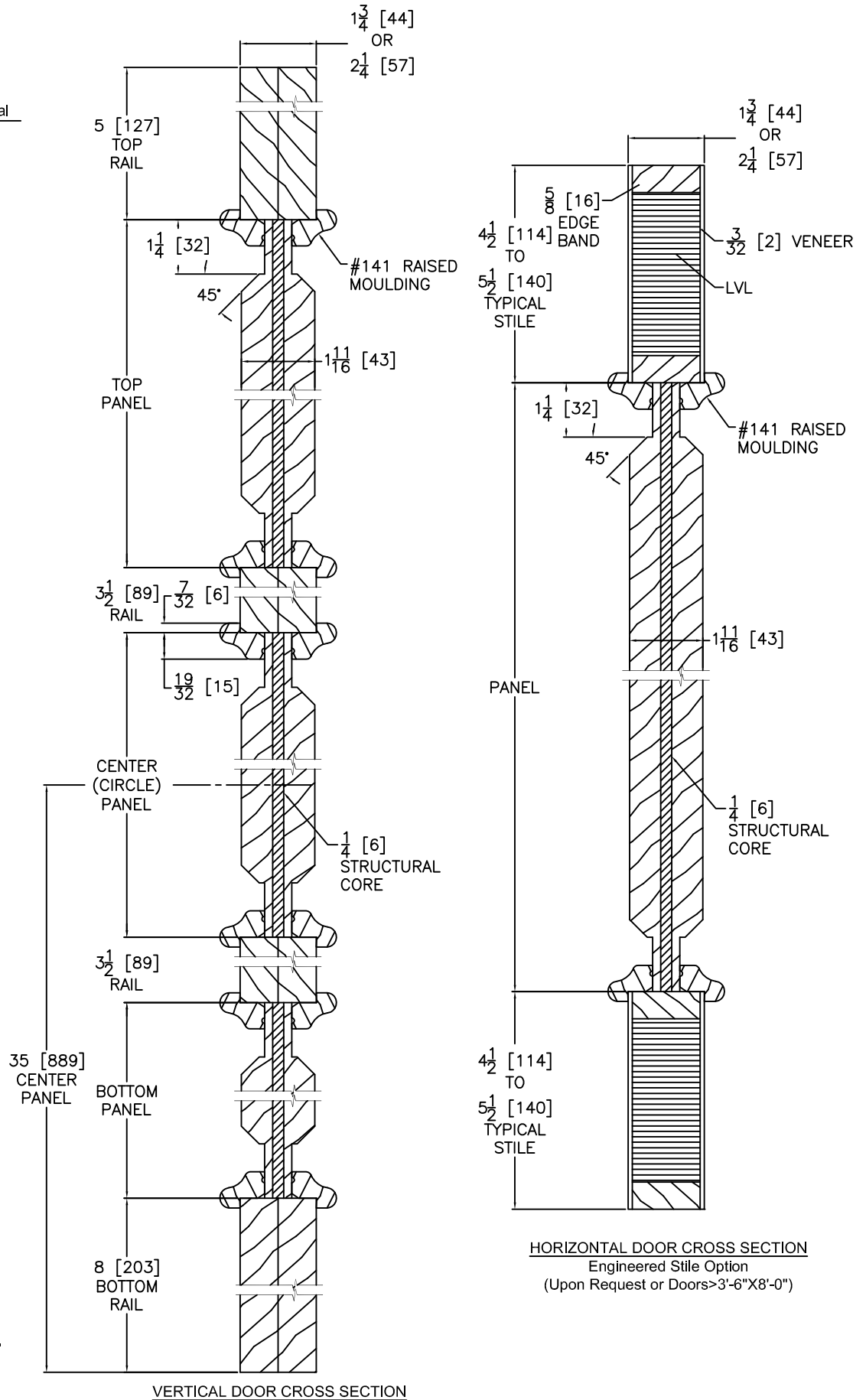
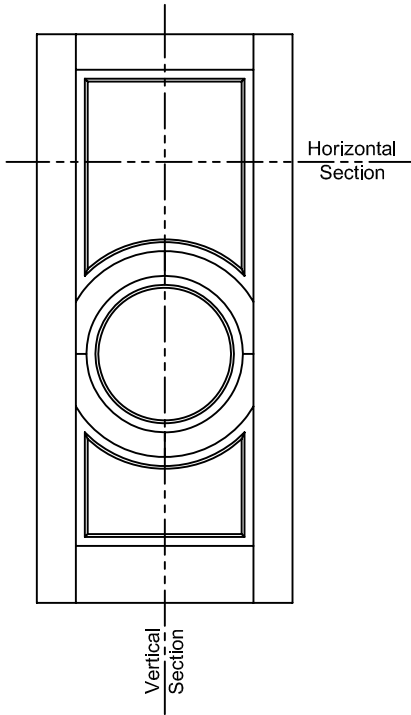

Notes:
Stile, Rail, Panel & Glass
vary by Size & Model of Door.
Typical Sizes are Shown.

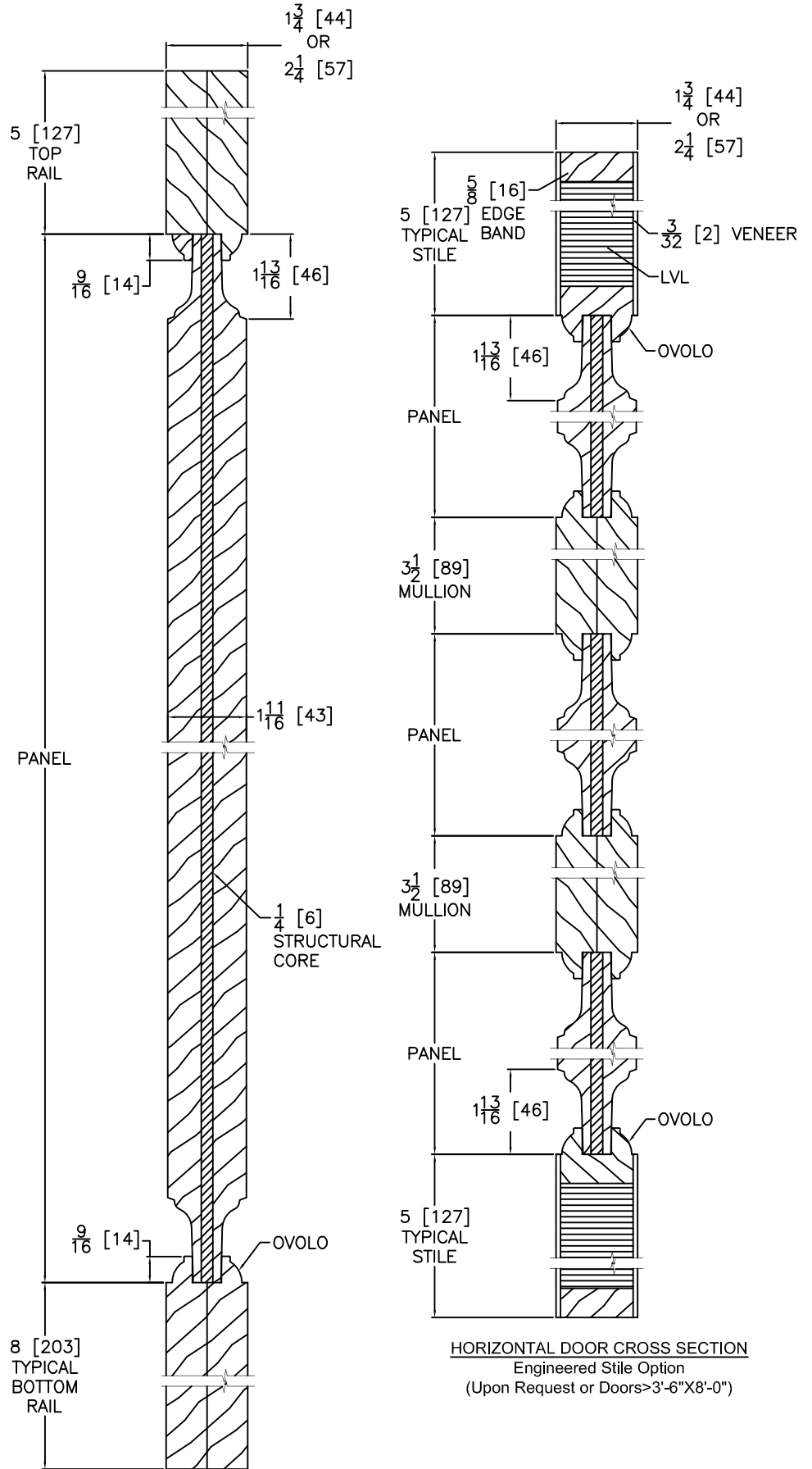
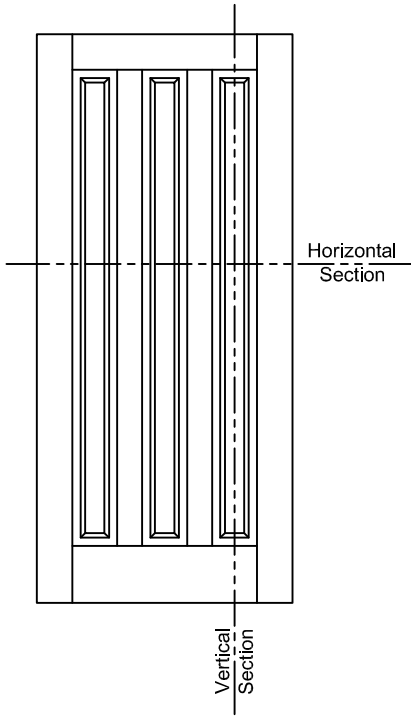

Notes:
Stile, Rail, Panel & Glass
vary by Size & Model of Door.
Typical Sizes are Shown.

VERTICAL DOOR CROSS SECTION

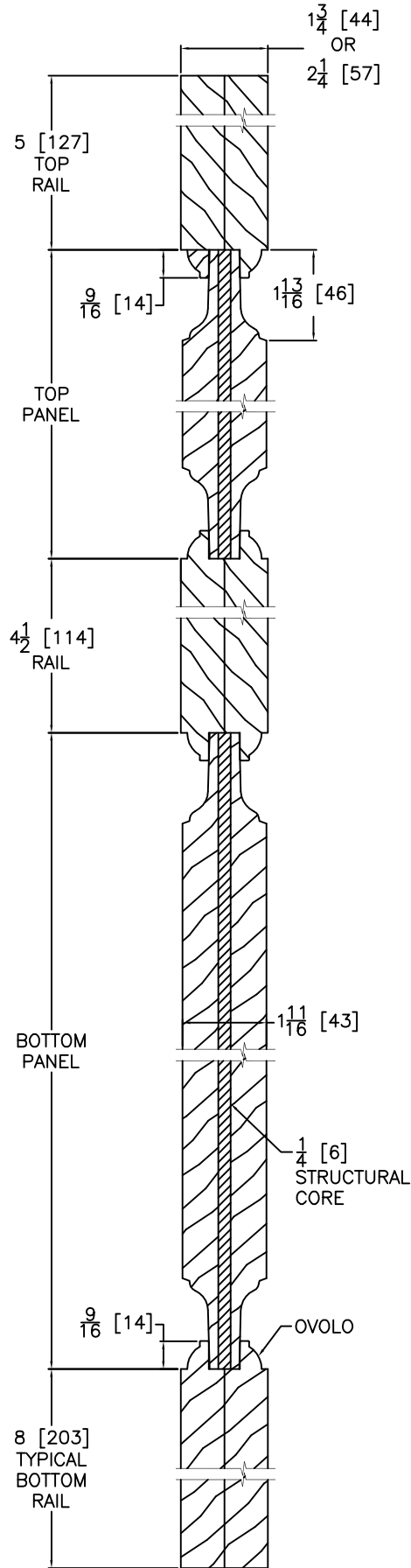
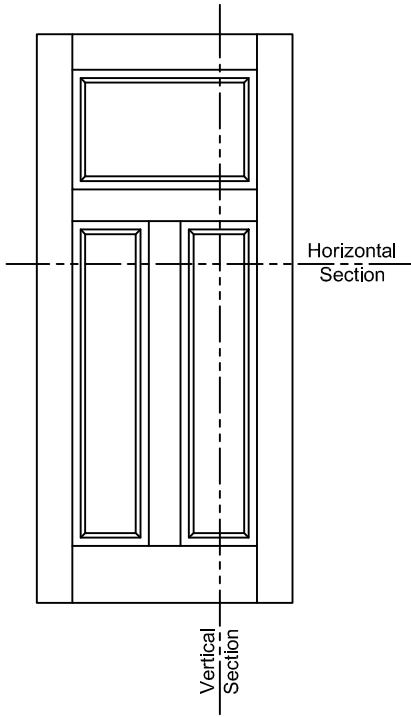

VERTICAL DOOR CROSS SECTION

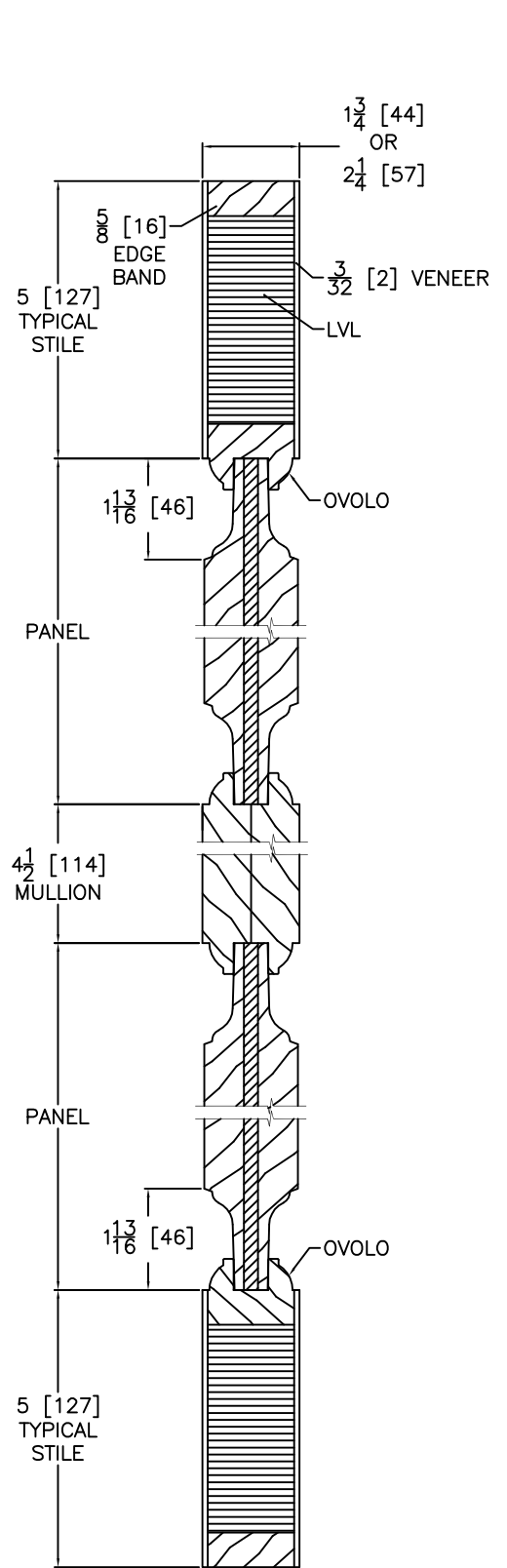

HORIZONTAL DOOR CROSS SECTION
Engineered Stile Option
(Upon Request or Doors > 3'-6" X 8'-0")

Notes:
Stile, Rail, Panel & Glass
vary by Size & Model of Door.
Typical Sizes are Shown.

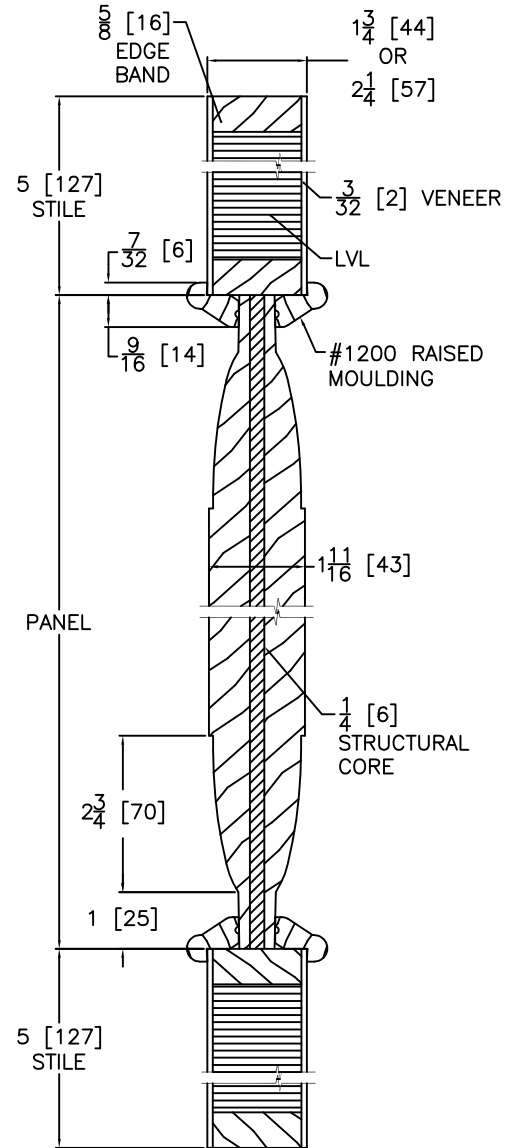
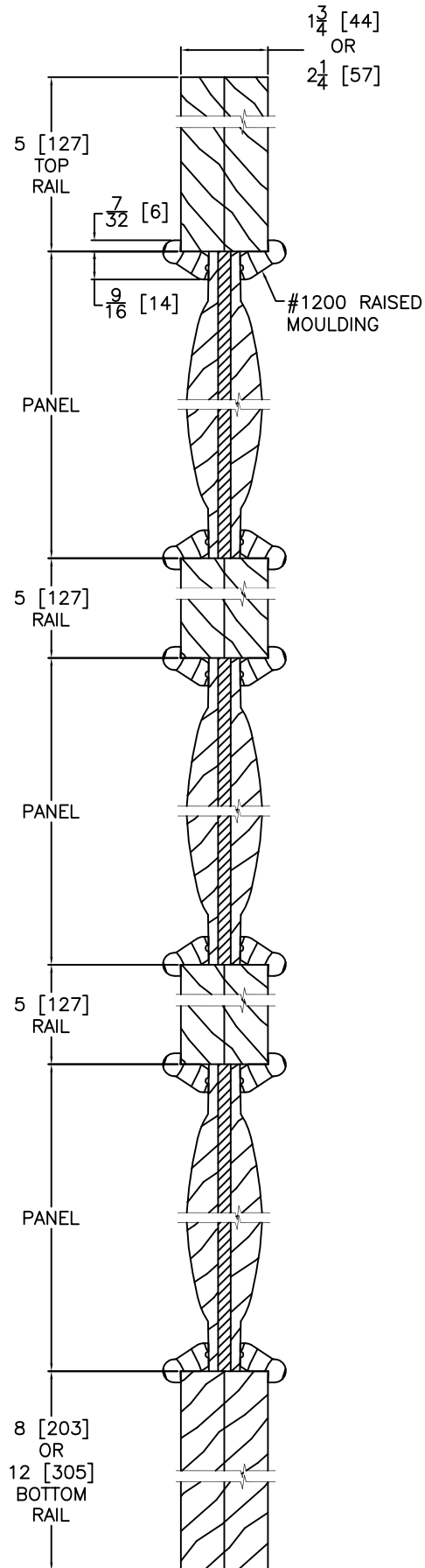
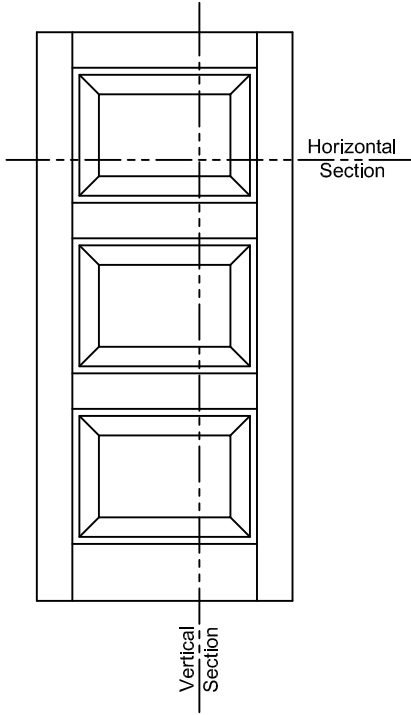

HORIZONTAL DOOR CROSS SECTION
Engineered Stile Option
(Upon Request or Doors > 3'-6" X 8'-0")

VERTICAL DOOR CROSS SECTION

Notes:
Stile, Rail, Panel & Glass
vary by Size & Model of Door.
Typical Sizes are Shown.

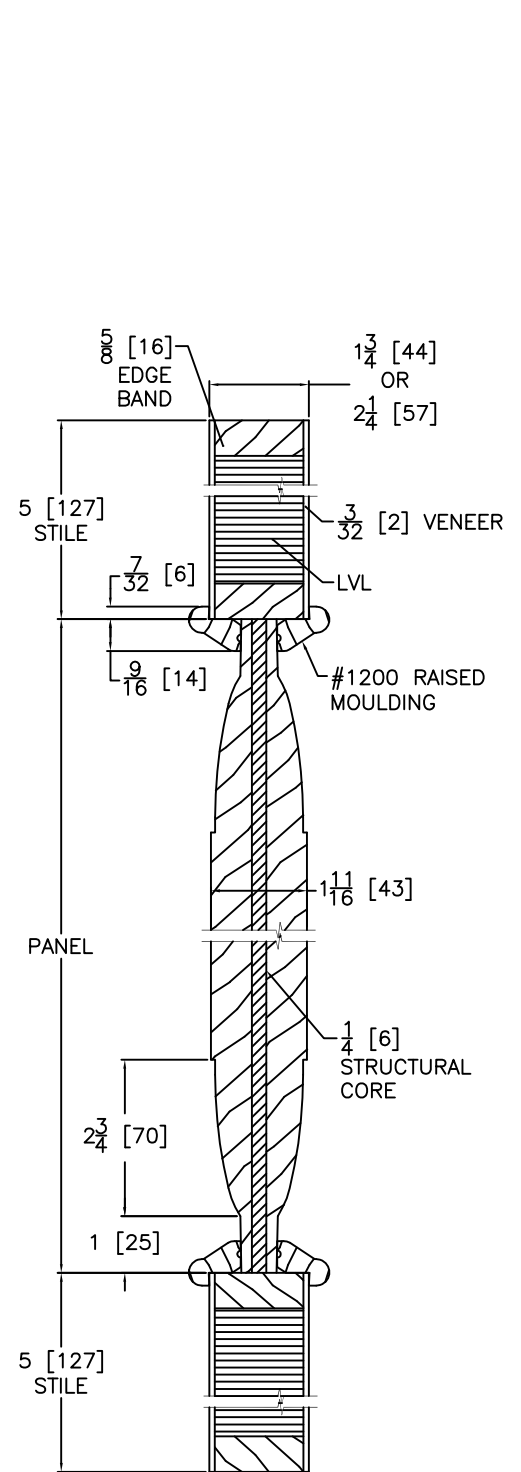
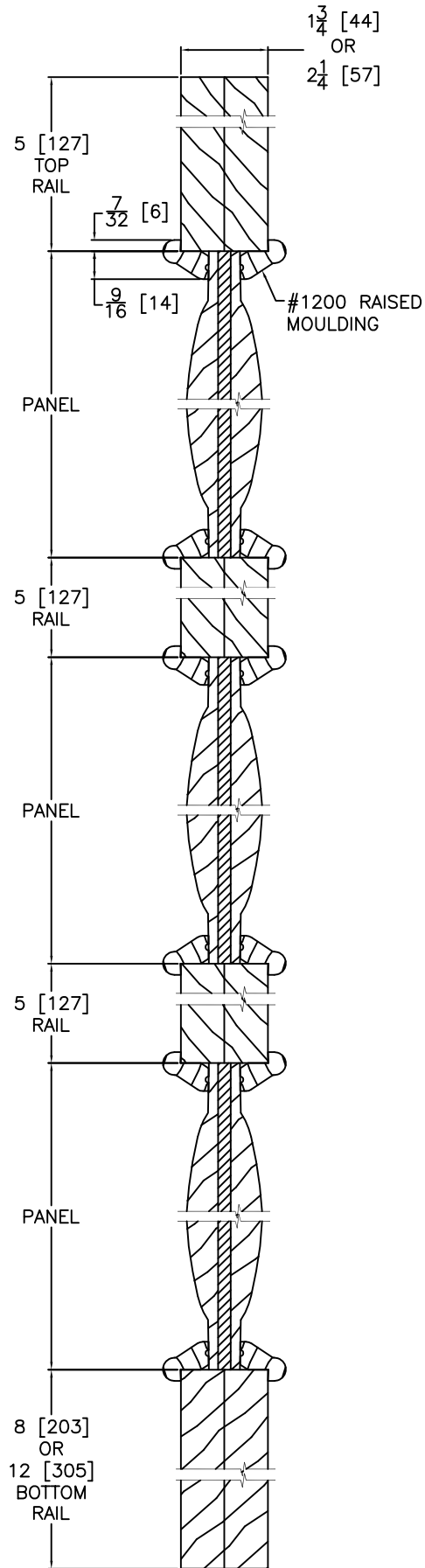
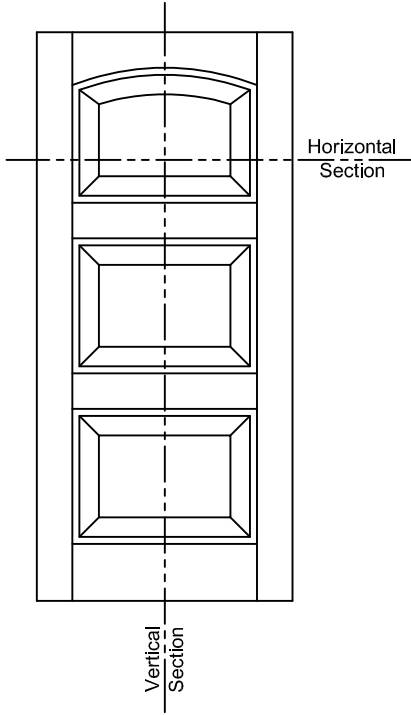

HORIZONTAL DOOR CROSS SECTION
Engineered Stile Option
(Upon Request or Doors > 3'-6" X 8'-0")

Notes:
Stile, Rail, Panel & Glass
vary by Size & Model of Door.
Typical Sizes are Shown.

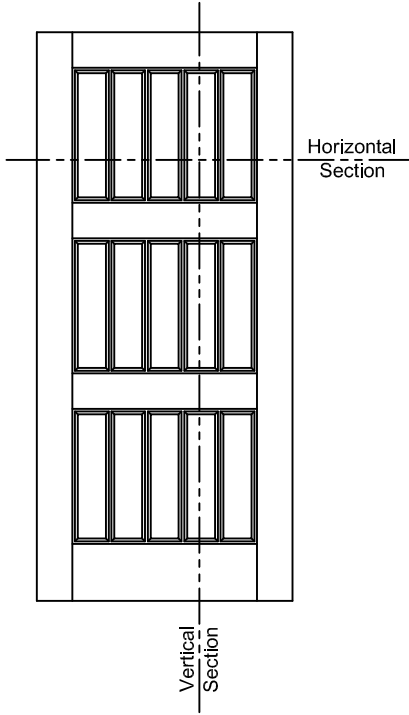

V-GROOVE/PLANK DETAILS

- 2-6 Door = 4 Planks, 3 23/32" Flat Area Width
- 2-8 Door = 4 Planks, 4 7/32" Flat Area Width
- 3-0 Door = 5 Planks, 3 15/16" Flat Area Width
- 3-6 Door = 6 Planks, 4 3/32" Flat Area Width

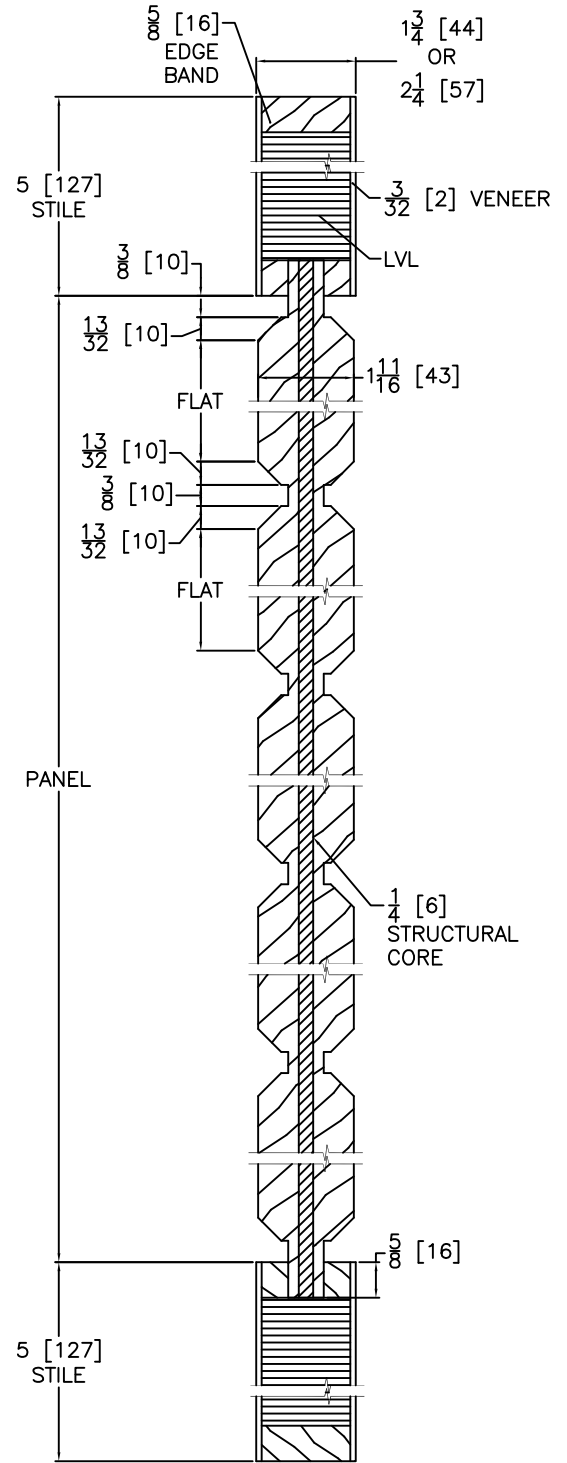
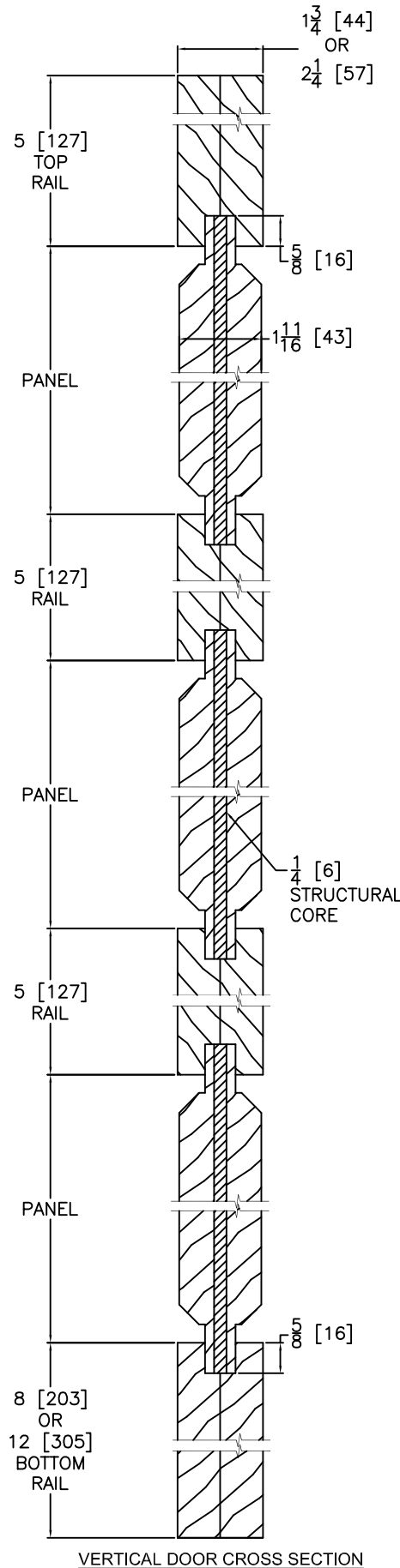

HORIZONTAL DOOR CROSS SECTION
Engineered Stile Option
(Upon Request or Doors > 3'-6" X 8'-0")

Notes:
Stile, Rail, Panel & Glass
vary by Size & Model of Door.
Typical Sizes are Shown.

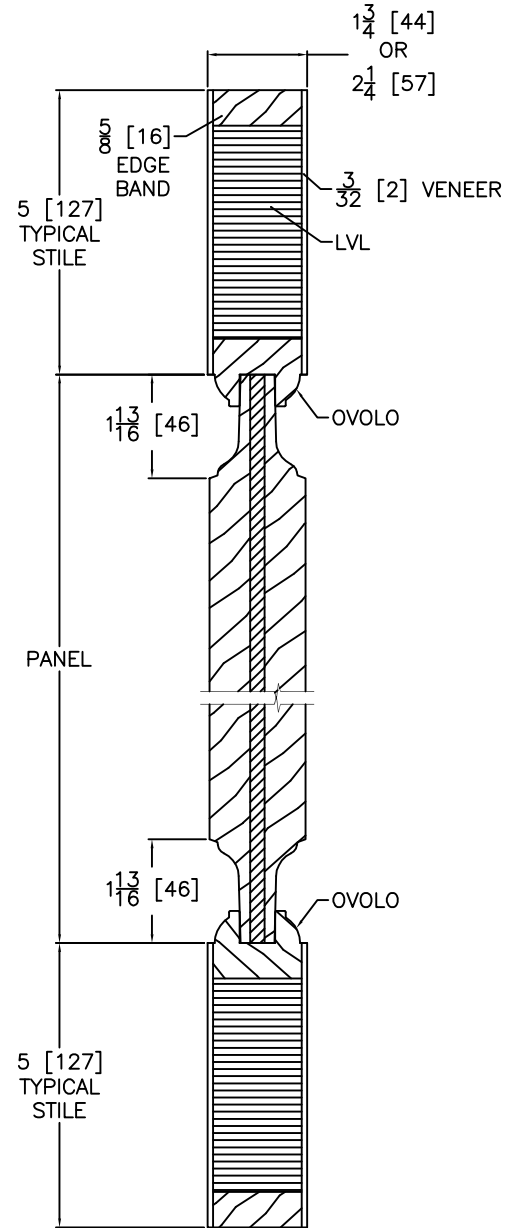
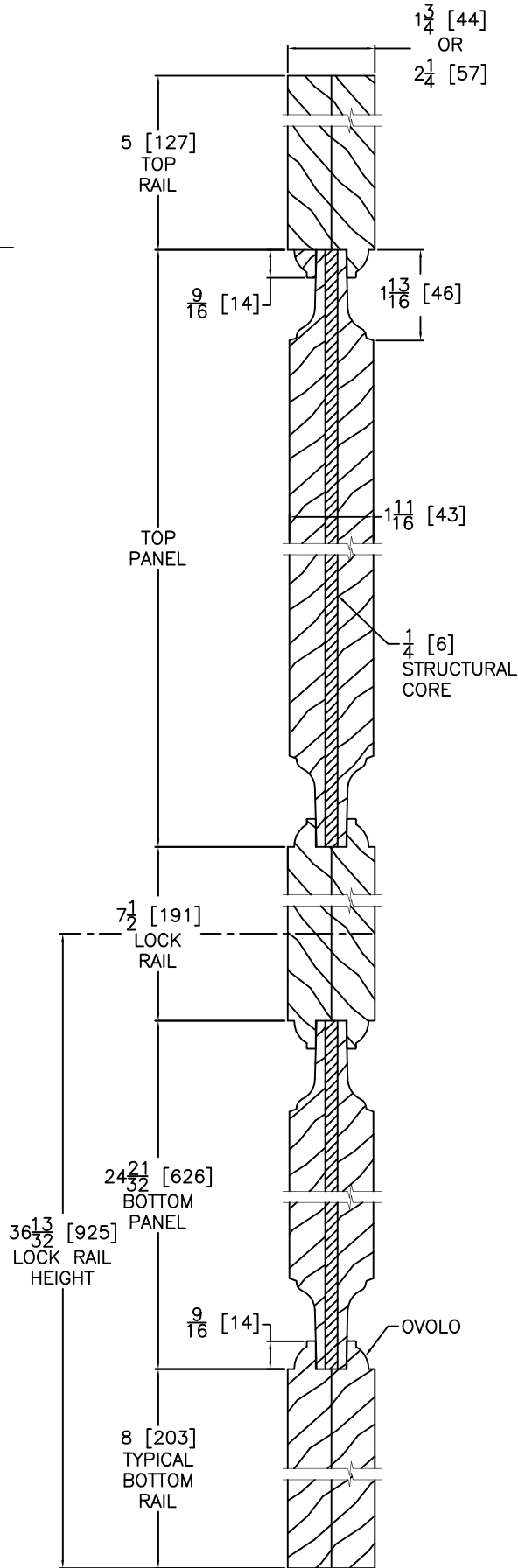
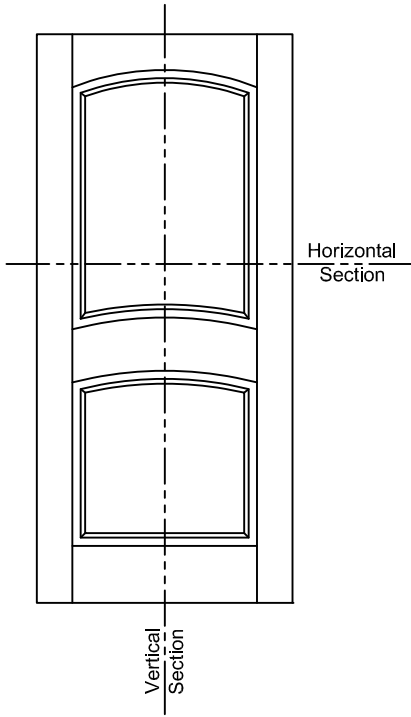

HORIZONTAL DOOR CROSS SECTION
Engineered Stile Option
(Upon Request or Doors >3'-6" X 8'-0")

VERTICAL DOOR CROSS SECTION

Notes:
Stile, Rail, Panel & Glass
vary by Size & Model of Door.
Typical Sizes are Shown.