TABLE OF CONTENTS

Specifications	3-2
Quick Spec Guide	3-4
Elevations/Sizes: 1/4" Scale	3-6
Awning	3-8
Glazing Options: 3" Scale	3-19
Trim Options: 3" Scale	3-21
Jamb Options: 3" Scale	3-20
Standard Mullion Options	3-23
Lite Cut Information	3-24
Vent Projections	3-27
Unit Sizing, Rough Openings & Masonry Openings	3-28
Section Details: 6" Scale	3-29

PRODUCT SPECIFICATIONS**EXTERIOR FINISH**

Exterior aluminum surfaces are low maintenance extruded aluminum coated with a thermo set polyester finish that meets or exceeds the AAMA 2603 performance standards. Standard colors include Brilliant White, Chestnut Bronze, Desert Sand, French Vanilla, Hartford Green, Mesa Red, Black, Arctic Silver and Dark Chocolate.

AURALAST® WOOD

AuraLast® wood is fundamentally different from wood resulting from traditional millwork preservation processes in that it uses a proprietary vacuum/pressure process to provide protection throughout the wood parts used to make windows and doors. AuraLast® wood is distinguished from wood using the current preservation methods by its unique ability to achieve greater penetration of the active ingredients into the wood parts, with a penetration of the treatment being a minimum of 92%.

INTERIOR FINISH

All interior surfaces are unfinished clear pine ready for on site finishing. Primed and pre-finished interiors are available in paint: Pure White, Extra White, Natural Choice, Moderate White; in stain: Wheat, Cherry, Fruitwood, Cordovan, Cider and Clear Lacquer. Optional interior wood species include mixed grain Douglas Fir and Knotty Alder.

FRAME

Frame is assembled from select kiln dried pine using AuraLast® wood on all exterior parts. Exterior surface is covered with .055 (1.4mm) extruded aluminum cladding; corner joints are mechanically fastened over a silicone injected nylon corner key. Frame thickness is 1-5/32" (29.4mm). Basic jamb width is 2-1/2" (63.5mm). Standard jamb width is 4-9/16" (116mm). Integral nailing fin is part of extrusion on all four sides. Assembled frame includes all weather-stripping and hardware installed. Exterior of frame extrusion is grooved to accept accessories.

SASH

Sash is 1-7/16" (36.5mm) thick and combines an extruded aluminum exterior with select kiln-dried pine using AuraLast® wood. Joints are mortise and tenoned, machine clamped for squareness and secured with metal fasteners. Exterior surfaces are covered with .045 (1.2mm) extruded aluminum.

GLAZING

3/4" (19mm) thick sealed insulating glass is constructed from two panes of glass, utilizing a continuous roll formed stainless steel spacer with dual seal sealant. The glass is mounted into the sash using a silicone-glazing compound and secured with interior applied profiled wood stops. All insulating glass units comply with the performance requirements of IGCC in accordance with either ASTM E774 or E2190.

GLAZING OPTIONS

3/4" insulating glass available in Low-E with Argon, Low-E, Low-E 366, Clear, Neat Glass, reflective, tinted, or obscure, tempered or other specialty glass as specified. Preserve® film is a 0.003" thick polyethylene film with a low tack acrylic adhesive applied to the glass for protection during shipping and installation. 4,000 foot elevations and higher require a capillary tube to equalize environmental stress (otherwise known as High Altitude glazing). High Altitude glazing does not allow the use of Argon as listed under glazing options.

WEATHER-STRIPPING

Engineered system combines a flexible, lined weather-strip applied to the full perimeter of the sash and thermoplastic rubber bulb applied to the full perimeter of the frame.

HARDWARE

Sash pivot on concealed hinges with sliding steel reinforced nylon shoes in an integral frame track. Stainless steel concealed locking system is standard. EntryGard awning dual arm roto-operator has removable polycarbonate cover, die cast zinc bash and hardened steel worm gears and arms. Hinges and roto-operator arms feature stainless steel. Two die cast locking levers are located on the side jambs at the lower corners of the window and have molded bezel covers that snap over the routs on the side stops. Units under 20" wide will feature a dyad operator. Color choices for locks and operator covers are White, Chestnut Bronze, Desert Sand or optional Bright Brass, Antique Brass, Polished Brass, Brushed Chrome or Imitation Oil Rubbed Bronze.

INTERIOR INSECT SCREENS

Charcoal fiberglass screen cloth (18x16 mesh) set in painted roll formed aluminum frame fitted to the inside of the window with all necessary hardware, in White, Chestnut Bronze, Desert Sand or optional Bright Brass, Antique Brass, Polished Brass, Brushed Chrome, or Imitation Oil Rubbed Bronze. Aluminum mesh and Phantom screen are also available. Insect screens are intended to allow air and light in and to keep insects out. They are not intended to keep anyone or anything from falling through an open window. For safety screens or other security devices contact your local building supply retailer.

GRILLES

SDL (Simulated Divided Lites) - extruded aluminum muntins permanently applied to the exterior of the insulating glass unit (not available on textured glass) in 7/8" (22mm), 1-1/8" (28.5mm), or 1-3/8" (34.9mm) widths, and a putty profile in 5/8" (15.9mm), 7/8" (22mm) and 1-1/8" (28.5mm) widths only. SDL is standard with a light bronze internal shadow bar to give a true divided lite appearance. As an option, SDL may be ordered with a silver shadow bar. Clear wood interior muntin bars match the exterior muntin width and are permanently bonded to the interior of the glass. Also available is a 2-5/16" (59mm) SDL bar, which simulates a double-hung checkrail.

Full Surround Wood Grilles - Rectangular unfinished clear pine wood grilles in 7/8" (22mm), 1-1/8" (28.6mm) and 1-3/8" (35mm) are available in patterns selected by the owner.

GBG (Grilles between the Glass) - 5/8" (15.9mm) flat and 23/32" or 1" contour mounted between the glass panes suspended within the air cavity.

EXTERIOR TRIM

1-5/8" (41mm) wide aluminum brickmould or Adams casing with an integral nailing fin is available factory applied. Also available is 3-1/2" (88.5mm) flat casing with an integral nailing fin. All of the accessories are .050" (1.3mm) extruded aluminum. Two sizes of frame expander, 1-7/8" (48mm) and 3-1/4" (83mm) may be used alone or in conjunction with a 2-1/8" (54mm) mull expander. Standard 5/16" (8mm) clad mull cover used for joining windows together. Windows may also be joined with 1" (25.4mm), 2" (51mm), or 4" (102mm) mull covers. Color and finish match exterior finish specs above.

Continued on next page

PRODUCT SPECIFICATIONS

EXTENSION JAMBS

Extension jambs are factory applied to the interior on all four sides of the frame and are 4/4 standard thick pine to accommodate wall depths up to 7-1/4" with one piece, and up to 12" with two pieces. 9/16" (14.2mm) and 5/4 option or 5/4-4/4 stacked option also available.

INSTALLATION

Installation per JELD-WEN Installation Method for Metal Clad Windows JII002 or JII013. See www.jeld-wen.com/resources for instructions.

PERFORMANCE

NFRC Certified - (Rated and labeled in accordance with NFRC)

WDMA Hallmark Certified -
In accordance with **AAMA/NWWDA/101/I.S.2-97**

QUICK SPEC GUIDE

SPECIFICATION	STANDARD FEATURES	OPTIONAL FEATURES <i>Some options may require additional lead times. Consult your JELD-WEN Sales Representative.</i>
EXTERIOR FINISH	<ul style="list-style-type: none"> • Brilliant White • Chestnut Bronze • Desert Sand • French Vanilla • Mesa Red • Hartford Green • Black • Arctic Silver • Dark Chocolate 	<ul style="list-style-type: none"> • Bronze • Heirloom White • Bone White • Dark Buckskin • Smoke • Mocha Cream • Hunter Green • Sage Brown • Redwood • Sea Foam • Ivory • Cascade
EXTERIOR TRIM	<ul style="list-style-type: none"> • Nailing Fin • Drip Cap 	<ul style="list-style-type: none"> • Aluminum 1-5/8" Brickmould with integral nailing fin • Adams or 3-1/2" Flat Casing with integral nailing fin • Clad Metal Drip Cap
INTERIOR WOOD	<ul style="list-style-type: none"> • Western Pine 	<ul style="list-style-type: none"> • Knotty Alder • Mixed Grain Douglas Fir
INTERIOR FINISH	<ul style="list-style-type: none"> • Natural 	<ul style="list-style-type: none"> • Priming Available <p>Pre-finished Interior Options are:</p> <ul style="list-style-type: none"> • Paint - Pure White, Extra White, Natural Choice, Moderate White • Stain - Wheat, Fruitwood, Cherry, Cordovan, Cider • Clear Lacquer
SIZE	<ul style="list-style-type: none"> • Width: Operators 18, 20, 24, 28, 30, 32, 36, 42, 48, 54, 60 • Height: Operators 18, 20, 24, 28, 30, 36, 42, 48 • For RO, add 3/4" 	<ul style="list-style-type: none"> • Operator - Any Width: 18" to 60" • Stationary - Enter as Casement • Operator - Any Height: 18" to 48" • Stationary - Enter as Casement <p>For 54, 60 max Height is 36"</p> <p>Clad Awning under 28" wide use a special narrow roto-operator</p> <ul style="list-style-type: none"> • For RO, add 3/4"
GLAZING	<ul style="list-style-type: none"> • Low-E Insulating Glass • Preserve® Protective Film 	<ul style="list-style-type: none"> • Clear • Obscure • Bronze • Low-E 366 • Neat Glass • Dual Low-E • Reflective • Tempered • Decorative Glass <ul style="list-style-type: none"> ○ Craftsman ○ Classic ○ Contemporary ○ Estate • Custom Design Capability
GRILLES		<ul style="list-style-type: none"> • High Altitude • 5/8" Flat, 23/32" or 1" Contour GBG • 7/8", 1-1/8", 1-3/8" Full Surround Wood Grilles <p>SDL Bead Profile:</p> <ul style="list-style-type: none"> • 7/8", 1-1/8", 1-3/8", 2-5/16" with Light Bronze Shadow Bar • 7/8", 1-1/8", 1-3/8", 2-5/16" with Silver Shadow Bar <p>SDL Putty Profile:</p> <ul style="list-style-type: none"> • 5/8", 7/8", 1-1/8" with Light Bronze Shadow Bar • 5/8", 7/8", 1-1/8" with Silver Shadow Bar

Continued on next page

QUICK SPEC GUIDE

SPECIFICATION	STANDARD FEATURES	OPTIONAL FEATURES
HARDWARE	<ul style="list-style-type: none"> • Standard Folding Nesting Handle • Concealed Locking System 	<p><i>Some options may require additional lead times. Consult your JELD-WEN Sales Representative.</i></p> <ul style="list-style-type: none"> • T-Handle • Round Knob
HARDWARE COLOR	<ul style="list-style-type: none"> • White • Desert Sand • Chestnut Bronze 	<ul style="list-style-type: none"> • Antique Brass • Polished Brass • Brushed Chrome • Oil Rubbed Bronze
JAMB	<ul style="list-style-type: none"> • 4-9/16" 	<ul style="list-style-type: none"> • Minimum: 2-1/2" • Maximum: 7-1/4" (one piece) • Maximum: 12" (two piece)
SCREENS	<ul style="list-style-type: none"> • BetterVue™ 	<ul style="list-style-type: none"> • Aluminum Mesh available • Phantom Screen - Limitations apply, factory-applied • UltraVue™
SCREEN FRAME COLOR	<ul style="list-style-type: none"> • Brilliant White • Desert Sand • Chestnut Bronze 	

GENERAL INFORMATION

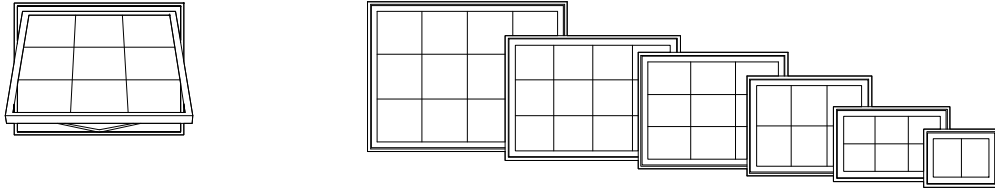

DIMENSIONAL WINDOWS

Clad awning windows may be specified as "dimensional" by adjusting the desired rough opening width or height in 1/4" increments from standard.

Clad awning windows are available as operating or stationary (non - venting). Operating mechanism includes corrosion resistant steel hinges and roto-type operators for venting units. Sash locks are concealed unison type with an exposed locking lever and escutcheon plate. There are several interior hardware finish options. Refer to the Specifications for finish options.

MULTIPLE ASSEMBLIES

Clad awning windows may be mullered above, below, or beside other clad awning windows, or other clad window products. Factory assembled mulls are limited in height (100"), width (150"), and a total area (75 square feet).

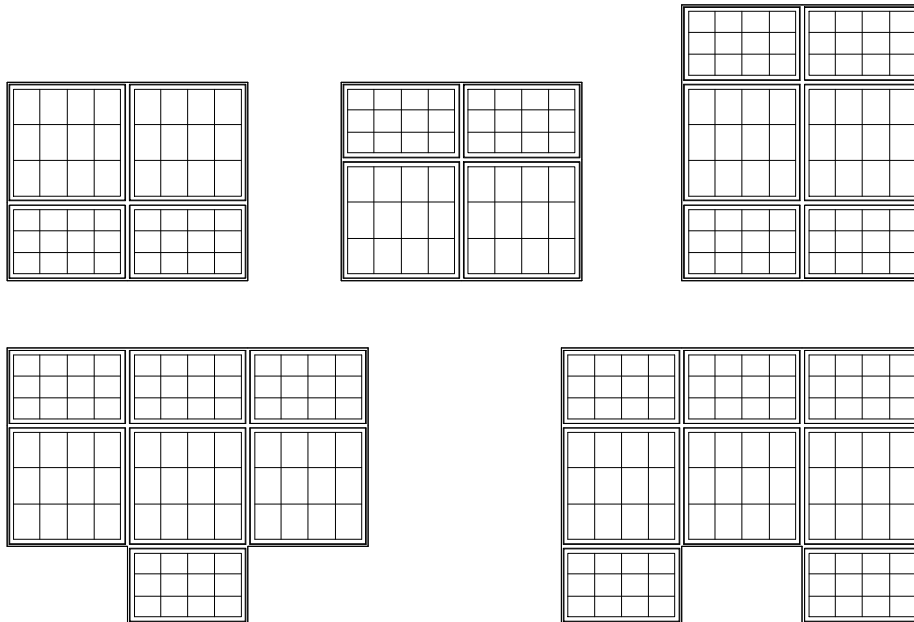

ELEVATION NOTES

ELEVATION DRAWINGS UTILIZE A LIMITED NUMBER OF PROJECTED LINES TO PRODUCE A RUDIMENTARY DRAWING INTENDED TO BE USED IN A SMALL GRAPHICAL SCALE. ELEVATIONS ARE VIEWED PERPENDICULAR FROM THE EXTERIOR OF THE STRUCTURE. IF MORE DIMENSIONS ARE NEEDED, USE THE SECTION DRAWINGS FOR MORE COMPLETE DEPICTIONS.

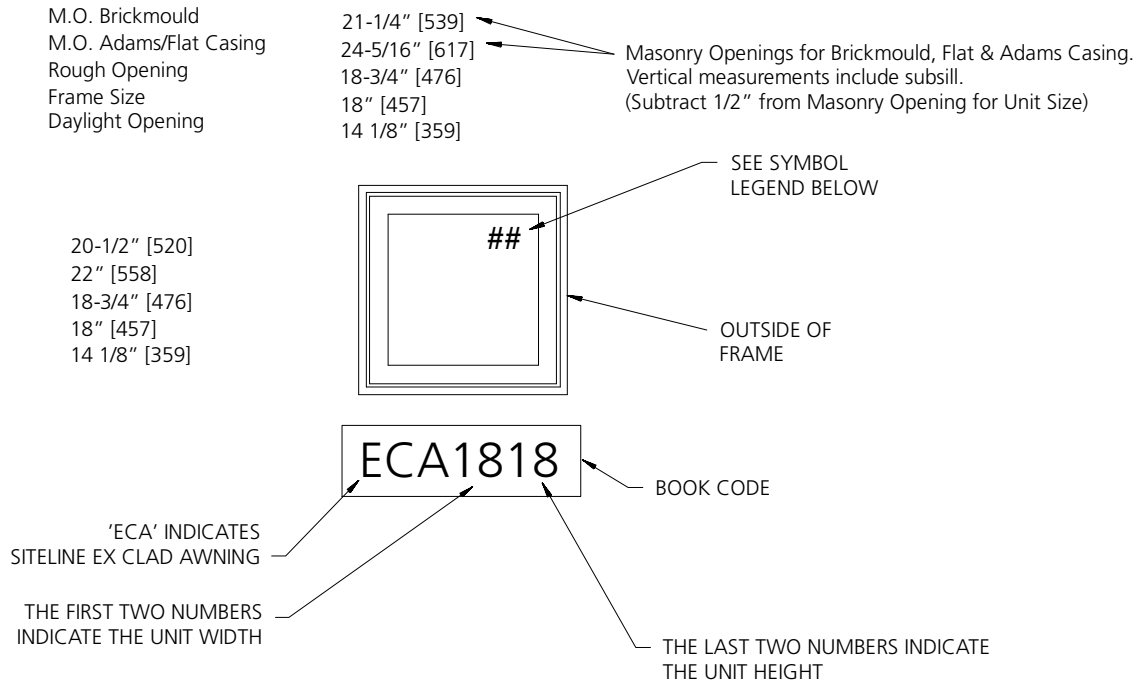

GENERAL AWNING NOTES

1. SITELINE EX CLAD AWNING (ECA) UNITS ARE AVAILABLE AS OPERATING OR STATIONARY UNITS.
2. UNIT ELEVATIONS ARE SHOWN WITHOUT EXTERIOR TRIM.
3. DIMENSIONAL VALUES IN PARENTHESES ARE MILLIMETER CONVERSIONS.

ELEVATION SYMBOL LEGEND:

- M.O.** MASONRY OPENING
- E** BASIC UNIT CLEAR OPENING EXCEEDS 20" IN WIDTH, 24" IN HEIGHT & A MINIMUM OF 5.7 SQ. FT.
- S** AVAILABLE AS STATIONARY ONLY.
- ##** NUMBER INDICATES DESIGN PRESSURE (DP) RATING WITH STANDARD GLAZING ON OPERATING OR STATIONARY UNITS. OPERATING UNITS UTILIZE A CONCEALED LOCKING SYSTEM FOR DP RATINGS.
- ##*** NUMBER INDICATES OPTIONAL DESIGN PRESSURE (DP) RATING ON OPERATING OR STATIONARY UNITS.

CLAD AWNING PICTURE COMBINATIONS

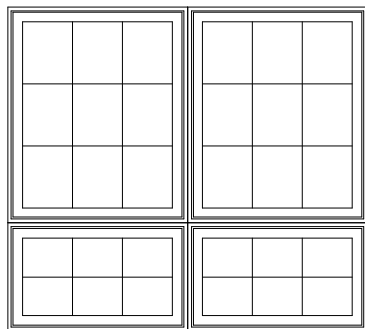

ECA303618

THE THIRD AND FOURTH NUMBERS OF THE BOOK CODE INDICATE THE PICTURE UNIT HEIGHT.

1-WIDE UNITS

M.O. BRICKMOULD	21 1/2"(546)	23 1/2"(597)	27 1/2"(699)	31 1/2"(800)	33 1/2"(851)	35 1/2"(902)	39 1/2"(1003)
M.O. ADAMS/FLAT CASING	24 1/2"(645)	26 1/2"(673)	30 1/2"(775)	34 1/2"(876)	36 1/2"(927)	38 1/2"(978)	42 1/2"(1080)
ROUGH OPENING	18 3/4"(476)	20 3/4"(527)	24 3/4"(629)	28 3/4"(730)	30 3/4"(781)	32 3/4"(832)	36 3/4"(933)
FRAME SIZE	18"(457)	20"(508)	24"(610)	28"(711)	30"(762)	32"(813)	36"(914)
DAYLIGHT OPENING	12 3/32"(307)	14 3/32"(358)	18 3/32"(460)	22 3/32"(561)	24 3/32"(612)	26 3/32"(663)	30 3/32"(764)
20 5/16"(515) 21 13/16"(554) 18 3/4"(476)							
ECA1818	ECA2018	ECA2418	ECA2818	ECA3018	ECA3218	ECA3618	
22 5/16"(578) 23 13/16"(605) 20 3/4"(527)							
ECA1820	ECA2020	ECA2420	ECA2820	ECA3020	ECA3220	ECA3620	
25 5/16"(668) 27 13/16"(706) 24 3/4"(629)							
ECA1824	ECA2024	ECA2424	ECA2824	ECA3024	ECA3224	ECA3624	
30 5/16"(770) 31 13/16"(808) 28 3/4"(730)							
ECA1828	ECA2028	ECA2428	ECA2828	ECA3028	ECA3228	ECA3628	
32 5/16"(821) 33 13/16"(859) 30 3/4"(781)							
ECA1830	ECA2030	ECA2430	ECA2830	ECA3030	ECA3230	ECA3630	
38 5/16"(973) 39 13/16"(1011) 36 3/4"(933)							
ECA1836	ECA2036	ECA2436	ECA2836	ECA3036	ECA3236	ECA3636	
44 5/16"(1126) 45 13/16"(1164) 42 3/4"(1086)							
ECA1842	ECA2042	ECA2442	ECA2842	ECA3042	ECA3242	ECA3642	
50 5/16"(1278) 51 13/16"(1316) 48 3/4"(1238)							
ECA1848	ECA2048	ECA2448	ECA2848	ECA3048	ECA3248	ECA3648	

ELEVATION SYMBOL LEGEND:

M.O. = MASONRY OPENING
 VALUES IN () ARE IN MILLIMETER CONVERSIONS
 ### INDICATES DESIGN PRESSURE (DP) RATING WITH STANDARD GLAZING
 ###* INDICATES OPTIONAL DESIGN PRESSURE (DP) RATING

Note: Elevations shown DO NOT have exterior trim. Subtract 1/2" (12.7) from M.O. (Masonry Opening) for Unit Sizes. Masonry Openings above include Sill Nose, see Trim Options page for Sill Nose specifications. For other Trim Options refer to the Unit Sizing, Rough Opening & Masonry Openings page.

SCALE 1/4" = 1'

1-WIDE UNITS

	21 1/2" (546)	23 1/2" (597)	27 1/2" (699)	31 1/2" (800)	33 1/2" (851)	35 1/2" (902)	39 1/2" (1003)
M.O. BRICKMOULD	24 1/2" (645)	26 1/2" (673)	30 1/2" (775)	34 1/2" (876)	36 1/2" (927)	38 1/2" (978)	42 1/2" (1080)
M.O. ADAMS/FLAT CASING	18 3/4" (476)	20 3/4" (527)	24 3/4" (629)	28 3/4" (730)	30 3/4" (781)	32 3/4" (832)	36 3/4" (933)
ROUGH OPENING	18" (457)	20" (508)	24" (610)	28" (711)	30" (762)	32" (813)	36" (914)
FRAME SIZE	12 3/32" (307)	14 3/32" (358)	18 3/32" (460)	22 3/32" (561)	24 3/32" (612)	26 3/32" (663)	30 3/32" (764)
DAYLIGHT OPENING							
	ECA1854	ECA2054	ECA2454	ECA2854	ECA3054	ECA3254	ECA3654
	ECA1860	ECA2060	ECA2460	ECA2860	ECA3060	ECA3260	ECA3660

56 5/16" (1430)
57 13/16" (1468)
54 3/4" (1391)
54" (1372)
48 3/32" (1222)

62 5/16" (1583)
63 13/16" (1621)
60 3/4" (1543)
60" (1524)
54 3/32" (1374)

ELEVATION SYMBOL LEGEND:
M.O. = MASONRY OPENING
VALUES IN () ARE IN MILLIMETER CONVERSIONS

Note: Elevations shown DO NOT have exterior trim. Subtract 1/2" (12.7) from M.O. (Masonry Opening) for Unit Sizes. Masonry Openings above include Sill Nose, see Trim Options page for Sill Nose specifications. For other Trim Options refer to the Unit Sizing, Rough Opening & Masonry Openings page.

SCALE 1/4" = 1'

1-WIDE UNITS

M.O. BRICKMOULD
M.O. ADAMS/FLAT CASING
ROUGH OPENING
FRAME SIZE
DAYLIGHT OPENING

45 1/2"(1156)
48 1/2"(1232)
42 3/4"(1086)
42"(1067)
36 3/32"(917)

51 1/2"(1308)
54 1/2"(1384)
48 3/4"(1238)
48"(1219)
42 3/32"(1070)

57 1/2"(1448)
60 1/2"(1537)
54 3/4"(1391)
54"(1372)
48 3/32"(1222)

63 1/2"(1613)
66 1/2"(1689)
60 3/4"(1543)
60"(1524)
54 3/32"(1374)

20 5/16"(515)
21 13/16"(554)
18 3/4"(476)
18"(457)
12 3/32"(307)



ECA4218



ECA4818



ECA5418



ECA6018

22 5/16"(578)
23 13/16"(605)
20 3/4"(527)
20"(508)
14 3/32"(358)

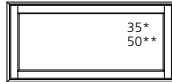

ECA4220



ECA4820



ECA5420



ECA6020

26 5/16"(668)
27 13/16"(706)
24 3/4"(629)
24"(610)
18 3/32"(460)



ECA4224



ECA4824



ECA5424



ECA6024

30 5/16"(770)
31 13/16"(808)
28 3/4"(730)
28"(711)
22 3/32"(561)



ECA4228



ECA4828



ECA5428



ECA6028

32 5/16"(821)
33 13/16"(859)
30 3/4"(781)
30"(762)
24 3/32"(612)



ECA4230



ECA4830



ECA5430



ECA6030

38 5/16"(973)
39 13/16"(1011)
36 3/4"(933)
36"(914)
30 3/32"(764)

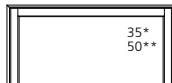

ECA4236

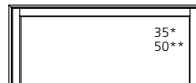

ECA4836



ECA5436



ECA6036

44 5/16"(1126)
45 13/16"(1164)
42 3/4"(1086)
42"(1067)
36 3/32"(917)



ECA4242



ECA4842



ECA5442



ECA6042

50 5/16"(1278)
51 13/16"(1316)
48 3/4"(1238)
48"(1219)
42 3/32"(1070)



ECA4248



ECA4848



ECA5448



ECA6048

ELEVATION SYMBOL LEGEND:

M.O. = MASONRY OPENING
VALUES IN () ARE IN MILLIMETER CONVERSIONS
###* INDICATES DESIGN PRESSURE (DP) RATING WITH STANDARD GLAZING
###** INDICATES OPTIONAL DESIGN PRESSURE (DP) RATING

Note: Elevations shown DO NOT have exterior trim. Subtract 1/2" (12.7) from M.O. (Masonry Opening) for Unit Sizes. Masonry Openings above include Sill Nose, see Trim Options page for Sill Nose specifications. For other Trim Options refer to the Unit Sizing, Rough Opening & Masonry Openings page.

SCALE 1/4" = 1'

1-WIDE UNITS

M.O. BRICKMOULD
M.O. ADAMS/FLAT CASING
ROUGH OPENING
FRAME SIZE
DAYLIGHT OPENING

45 1/2"(1156)
48 1/2"(1232)
42 3/4"(1086)
42"(1067)
36 3/32"(917)

51 1/2"(1308)
54 1/2"(1384)
48 3/4"(1238)
48"(1219)
42 3/32"(1070)

57 1/2"(1448)
60 1/2"(1537)
54 3/4"(1391)
54"(1372)
48 3/32"(1222)

56 5/16"(1430)
57 13/16"(1468)
54 3/4"(1391)
54"(1372)
48 3/32"(1222)

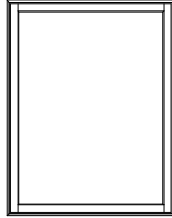

ECA4254

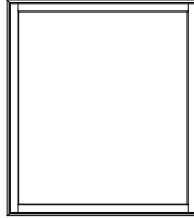

ECA4854

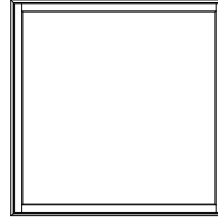

ECA5454

62 5/16"(1583)
63 13/16"(1621)
60 3/4"(1543)
60"(1524)
54 3/32"(1374)

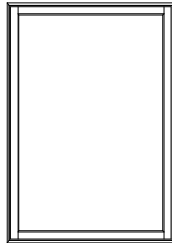

ECA4260

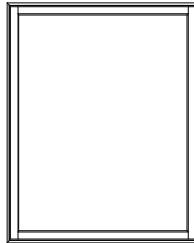

ECA4860

ELEVATION SYMBOL LEGEND:
M.O. = MASONRY OPENING
VALUES IN () ARE IN MILLIMETER CONVERSIONS

Note: Elevations shown DO NOT have exterior trim. Subtract 1/2" (12.7) from M.O. (Masonry Opening) for Unit Sizes. Masonry Openings above include Sill Nose, see Trim Options page for Sill Nose specifications. For other Trim Options refer to the Unit Sizing, Rough Opening & Masonry Openings page.

SCALE 1/4" = 1'

2-WIDE UNITS

	39 1/2" (1003)	43 1/2" (1105)	51 1/2" (1308)	59 1/2" (1511)	63 1/2" (1613)	67 1/2" (1715)	75 1/2" (1918)
MO BRICKMOLD	42 1/2" (1054)	46 1/2" (1181)	54 1/2" (1384)	62 1/2" (1588)	66 1/2" (1689)	70 1/2" (1791)	78 1/2" (1994)
MO FLAT CASING	36 3/4" (933)	40 3/4" (1035)	48 3/4" (1238)	56 3/4" (1441)	60 3/4" (1543)	64 3/4" (1645)	72 3/4" (1848)
ROUGH OPENING	36" (914)	40" (1016)	48" (1219)	56" (1422)	60" (1524)	64" (1626)	72" (1829)
FRAME SIZE	12 3/32" (307)[2]	14 3/32" (358)[3]	18 3/32" (460)[3]	22 3/32" (561)[3]	24 3/32" (612)[3]	26 3/32" (663)[3]	30 3/32" (764)[3]
DAYLIGHT OPENING							
20 5/16" (515)							
20 5/16" (515)	ECA1818-2	ECA2018-2	ECA2418-2	ECA2818-2	ECA3018-2	ECA3218-2	ECA3618-2
21 13/16" (554)							
21 13/16" (554)	ECA1820-2	ECA2020-2	ECA2420-2	ECA2820-2	ECA3020-2	ECA3220-2	ECA3620-2
22 5/16" (578)							
22 5/16" (578)	ECA1824-2	ECA2024-2	ECA2424-2	ECA2824-2	ECA3024-2	ECA3224-2	ECA3624-2
23 13/16" (605)							
23 13/16" (605)	ECA1830-2	ECA2030-2	ECA2430-2	ECA2830-2	ECA3030-2	ECA3230-2	ECA3630-2
24 3/4" (629)							
24 3/4" (629)	ECA1836-2	ECA2036-2	ECA2436-2	ECA2836-2	ECA3036-2	ECA3236-2	ECA3636-2
24 3/4" (629)							
24 3/4" (629)	ECA1842-2	ECA2042-2	ECA2442-2	ECA2842-2	ECA3042-2	ECA3242-2	ECA3642-2
26 5/16" (668)							
26 5/16" (668)	ECA1848-2	ECA2048-2	ECA2448-2	ECA2848-2	ECA3048-2	ECA3248-2	ECA3648-2
27 13/16" (706)							
27 13/16" (706)							
30 3/4" (781)							
30 3/4" (781)							
30 3/4" (781)							
30 3/4" (781)							
32 5/16" (821)							
32 5/16" (821)							
33 13/16" (859)							
33 13/16" (859)							
36 3/4" (933)							
36 3/4" (933)							
36 3/4" (933)							
36 3/4" (933)							
38 5/16" (973)							
38 5/16" (973)							
39 13/16" (1011)							
39 13/16" (1011)							
42 1" (1067)							
42 1" (1067)							
42 1" (1067)							
42 1" (1067)							
44 5/16" (1126)							
44 5/16" (1126)							
45 13/16" (1164)							
45 13/16" (1164)							
48 3/4" (1238)							
48 3/4" (1238)							
48 3/4" (1238)							
48 3/4" (1238)							
50 5/16" (1278)							
50 5/16" (1278)							
51 13/16" (1316)							
51 13/16" (1316)							

ELEVATION SYMBOL LEGEND:

M.O. = MASONRY OPENING
VALUES IN () ARE IN MILLIMETER CONVERSIONS
VALUES IN [] ARE NUMBER OF DAYLIGHT OPENINGS PER UNIT

Note: Elevations shown DO NOT have exterior trim. Subtract 1/2" (12.7) from M.O. (Masonry Opening) for Unit Sizes. Masonry Openings above include Sill Nose, see Trim Options page for Sill Nose specifications. For other Trim Options refer to the Unit Sizing, Rough Opening & Masonry Openings page.

SCALE 1/4" = 1'

2-WIDE UNITS

MO BRICKMOLD MO FLAT CASING ROUGH OPENING FRAME SIZE DAYLIGHT OPENING	87 1/2"(2223) 90 1/2"(2299) 84 3/4"(2153) 84"(2134) 36 3/32"(917)[3]	99 1/2"(2527) 102 1/2"(2604) 96 3/4"(2457) 96"(2438) 42 3/32"(1070)[3]
20 5/16"(515) 21 13/16"(554) 18 3/4"(476) 18"(457) 12 3/32"(307)		
22 5/16"(578) 23 13/16"(605) 20 3/4"(527) 20"(508) 14 3/32"(358)		
26 5/16"(668) 27 13/16"(706) 24 3/4"(629) 24"(610) 18 3/32"(460)		
32 5/16"(821) 33 13/16"(859) 30 3/4"(781) 30"(762) 24 3/32"(612)		
38 5/16"(973) 39 13/16"(1011) 36 3/4"(933) 36"(914) 30 3/32"(764)		
44 5/16"(1126) 45 13/16"(1164) 42 3/4"(1086) 42"(1067) 36 3/32"(917)		
50 5/16"(1278) 51 13/16"(1316) 48 3/4"(1238) 48"(1219) 42 3/32"(1070)		

ELEVATION SYMBOL LEGEND:
M.O. = MASONRY OPENING
VALUES IN () ARE IN MILLIMETER CONVERSIONS
VALUES IN [] ARE NUMBER OF DAYLIGHT OPENINGS PER UNIT

Note: Elevations shown DO NOT have exterior trim. Subtract 1/2" (12.7) from M.O. (Masonry Opening) for Unit Sizes. Masonry Openings above include Sill Nose, see Trim Options page for Sill Nose specifications. For other Trim Options refer to the Unit Sizing, Rough Opening & Masonry Openings page.

SCALE 1/4" = 1'

3-WIDE UNITS

	MO BRICKMOLD	MO FLAT CASING	ROUGH OPENING	FRAME SIZE	DAYLIGHT OPENING	39 1/2"(1003)	43 1/2"(1105)	51 1/2"(1308)	59 1/2"(1511)	63 1/2"(1613)	67 1/2"(1715)
						42 1/2"(1054)	46 1/2"(1181)	54 1/2"(1384)	62 1/2"(1588)	66 1/2"(1689)	70 1/2"(1791)
						36 3/4"(933)	40 3/4"(1035)	48 3/4"(1238)	56 3/4"(1441)	60 3/4"(1543)	64 3/4"(1645)
						36"(914)	40"(1016)	48"(1219)	56"(1422)	60"(1524)	64"(1626)
						12 3/32"(307)[3]	14 3/32"(358)[3]	18 3/32"(460)[3]	22 3/32"(561)[3]	24 3/32"(612)[3]	26 3/32"(663)[3]
20 5/16"(515)						ECA1818-3	ECA2018-3	ECA2418-3	ECA2818-3	ECA3018-3	ECA3218-3
21 13/16"(554)											
18 4/5"(457)						ECA1820-3	ECA2020-3	ECA2420-3	ECA2820-3	ECA3020-3	ECA3220-3
22 5/16"(578)											
23 13/16"(605)											
20 3/4"(527)						ECA1824-3	ECA2024-3	ECA2424-3	ECA2824-3	ECA3024-3	ECA3224-3
20 5/8"(519)											
14 3/32"(358)											
26 5/16"(668)						ECA1830-3	ECA2030-3	ECA2430-3	ECA2830-3	ECA3030-3	ECA3230-3
27 13/16"(706)											
24 3/4"(629)						ECA1836-3	ECA2036-3	ECA2436-3	ECA2836-3	ECA3036-3	ECA3236-3
24 1/2"(610)											
30 1/2"(762)						ECA1842-3	ECA2042-3	ECA2442-3	ECA2842-3	ECA3042-3	ECA3242-3
30 1/8"(754)											
24 3/32"(612)											
32 5/16"(821)						ECA1848-3	ECA2048-3	ECA2448-3	ECA2848-3	ECA3048-3	ECA3248-3
33 13/16"(859)											
30 3/4"(781)						ECA1842-3	ECA2042-3	ECA2442-3	ECA2842-3	ECA3042-3	ECA3242-3
30 1/2"(762)											
36 1/4"(914)						ECA1836-3	ECA2036-3	ECA2436-3	ECA2836-3	ECA3036-3	ECA3236-3
36 1/8"(906)											
30 3/32"(764)											
38 5/16"(973)						ECA1842-3	ECA2042-3	ECA2442-3	ECA2842-3	ECA3042-3	ECA3242-3
39 13/16"(1011)											
36 3/4"(933)						ECA1848-3	ECA2048-3	ECA2448-3	ECA2848-3	ECA3048-3	ECA3248-3
36 1/4"(906)											
44 5/16"(1126)						ECA1842-3	ECA2042-3	ECA2442-3	ECA2842-3	ECA3042-3	ECA3242-3
45 13/16"(1164)											
42 3/4"(1086)						ECA1848-3	ECA2048-3	ECA2448-3	ECA2848-3	ECA3048-3	ECA3248-3
42 1/2"(1067)											
36 3/32"(917)											
50 5/16"(1278)						ECA1848-3	ECA2048-3	ECA2448-3	ECA2848-3	ECA3048-3	ECA3248-3
51 13/16"(1316)											
48 3/4"(1238)						ECA1848-3	ECA2048-3	ECA2448-3	ECA2848-3	ECA3048-3	ECA3248-3
46 1/2"(1170)											
42 3/32"(1070)											

ELEVATION SYMBOL LEGEND:
M.O. = MASONRY OPENING
 VALUES IN () ARE IN MILLIMETER CONVERSIONS
 VALUES IN [] ARE NUMBER OF DAYLIGHT OPENINGS PER UNIT

Note: Elevations shown DO NOT have exterior trim. Subtract 1/2" (12.7) from M.O. (Masonry Opening) for Unit Sizes. Masonry Openings above include Sill Nose, see Trim Options page for Sill Nose specifications. For other Trim Options refer to the Unit Sizing, Rough Opening & Masonry Openings page.

SCALE 1/4" = 1'

3-WIDE UNITS

**MO BRICKMOLD
MO FLAT CASING
ROUGH OPENING
FRAME SIZE
DAYLIGHT OPENING**

75 1/2" (1918)
78 1/2" (1994)
72 3/4" (1848)
72" (1829)
30 3/32" (764)[3]

129 1/2" (3289)
132 1/2" (3366)
126 3/4" (3219)
126" (3200)
36 3/32" (917)[3]

147 1/2" (3747)
150 1/2" (3823)
144 3/4" (3677)
144" (3658)
42 3/32" (1070)[3]

20 5/16" (515)
21 13/16" (554)
18 3/4" (476)
18" (457)
12 3/32" (307)



ECA3618-3

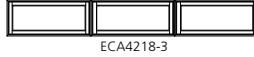

ECA4218-3

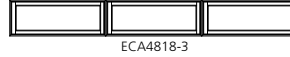

ECA4818-3

22 5/16" (578)
23 13/16" (605)
20 3/4" (527)
20" (508)
14 3/32" (358)



ECA3620-3



ECA4220-3

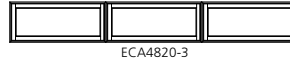

ECA4820-3

26 5/16" (668)
27 13/16" (706)
24 3/4" (629)
24" (610)
18 3/32" (460)

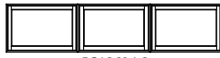

ECA3624-3



ECA4224-3

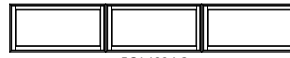

ECA4824-3

32 5/16" (821)
33 13/16" (859)
30 3/4" (781)
30" (762)
24 3/32" (612)

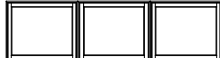

ECA3630-3

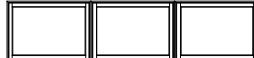

ECA4230-3

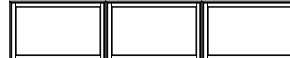

ECA4830-3

38 5/16" (973)
39 13/16" (1011)
36 3/4" (933)
36" (914)
30 3/32" (764)



ECA3636-3



ECA4236-3



ECA4836-3

44 5/16" (1126)
45 13/16" (1164)
42 3/4" (1086)
42" (1067)
36 3/32" (917)



ECA3642-3



ECA4242-3



ECA4842-3

50 5/16" (1278)
51 13/16" (1316)
48 3/4" (1238)
48" (1219)
42 3/32" (1070)



ECA3648-3



ECA4248-3

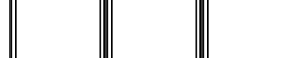

ECA4848-3



ELEVATION SYMBOL LEGEND:

M.O. = MASONRY OPENING
VALUES IN () ARE IN MILLIMETER CONVERSIONS
VALUES IN [] ARE NUMBER OF DAYLIGHT OPENINGS PER UNIT

Note: Elevations shown DO NOT have exterior trim. Subtract 1/2" (12.7) from M.O. (Masonry Opening) for Unit Sizes. Masonry Openings above include Sill Nose, see Trim Options page for Sill Nose specifications. For other Trim Options refer to the Unit Sizing, Rough Opening & Masonry Openings page.

SCALE 1/4" = 1'

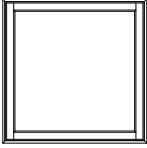
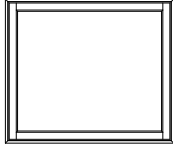
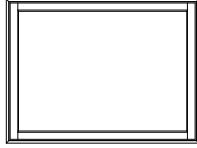
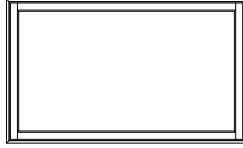
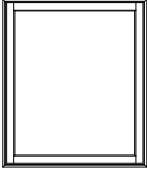
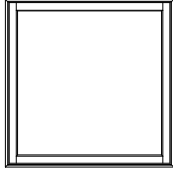
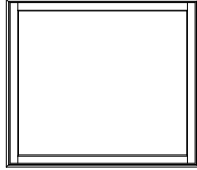
PICTURE UNITS

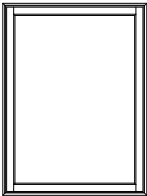
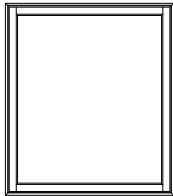
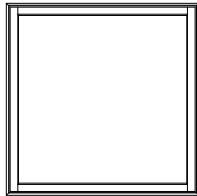
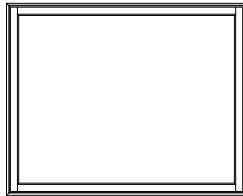
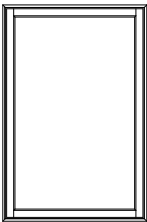
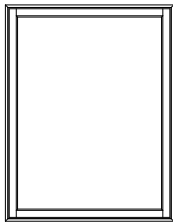
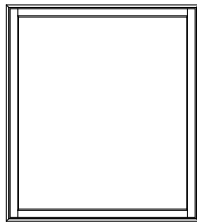
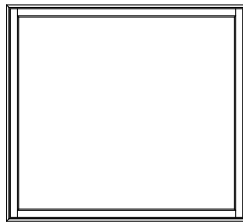
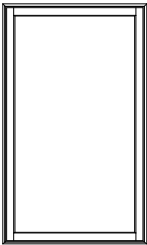
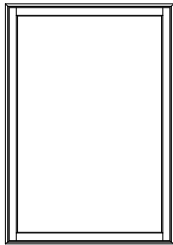
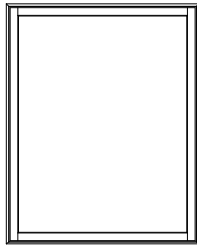
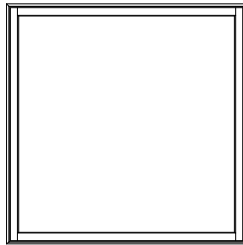
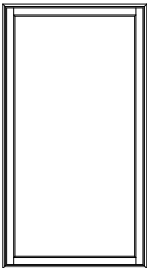
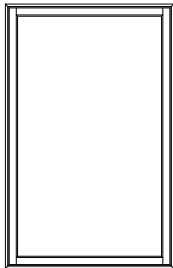
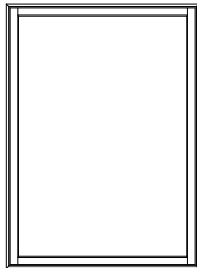
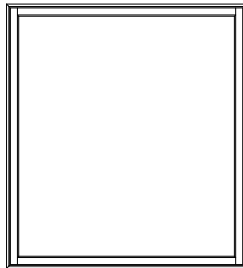
	M.O. BRICKMOULD M.O. ADAMS/FLAT CASING ROUGH OPENING FRAME SIZE DAYLIGHT OPENING	39 1/2"(1003) 42 1/2"(1080) 36 3/4"(933) 36"(914) 30 3/32"(764)	45 1/2"(1156) 46 1/2"(1181) 42 3/4"(1086) 42"(1067) 36 3/32"(917)	51 1/2"(1308) 54 1/2"(1384) 48 3/4"(1238) 48"(1219) 42 3/32"(1070)	63 1/2"(1613) 66 1/2"(1689) 60 3/4"(1543) 60"(1524) 54 3/32"(1374)
38 5/16"(973) 39 13/16"(1011) 36 3/4"(933) 36"(914) 30 3/32"(764)					
44 5/16"(1126) 45 13/16"(1164) 42 3/4"(1086) 39 3/32"(993)					
50 5/16"(1278) 51 13/16"(1316) 48 3/4"(1238) 48"(1219) 45 3/32"(1145)					
56 5/16"(1430) 57 13/16"(1468) 54 3/4"(1391) 54"(1317) 48 3/32"(1222)					
62 5/16"(1583) 63 13/16"(1621) 60 3/4"(1543) 60"(1524) 54 3/32"(1374)					
68 5/16"(1735) 69 13/16"(1773) 66 3/4"(1695) 66"(1676) 60 3/32"(1526)					

ELEVATION SYMBOL LEGEND:
M.O. = MASONRY OPENING
VALUES IN () ARE IN MILLIMETER CONVERSIONS

Note: Elevations shown DO NOT have exterior trim. Subtract 1/2" (12.7) from M.O. (Masonry Opening) for Unit Sizes. Masonry Openings above include Sill Nose, see Trim Options page for Sill Nose specifications. For other Trim Options refer to the Unit Sizing, Rough Opening & Masonry Openings page.

SCALE 1/4" = 1'

PICTURE UNITS

M.O. BRICKMOULD
M.O. ADAMS/FLAT CASING
ROUGH OPENING
FRAME SIZE
DAYLIGHT OPENING

39 1/2"(1003)
42 1/2"(1080)
36 3/4"(933)
36"(914)
30 3/32"(764)

45 1/2"(1156)
46 1/2"(1181)
42 3/4"(1086)
42"(1067)
36 3/32"(917)

51 1/2"(1308)
54 1/2"(1384)
48 3/4"(1238)
48"(1219)
42 3/32"(1070)

63 1/2"(1613)
66 1/2"(1689)
60 3/4"(1543)
60"(1524)
54 3/32"(1374)

74 5/16"(1888)
75 13/16"(1926)
77 3/4"(1978)
72"(1829)
66 3/32"(1679)

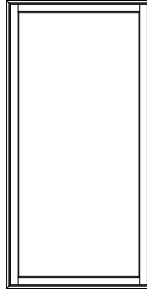

ECAP3672

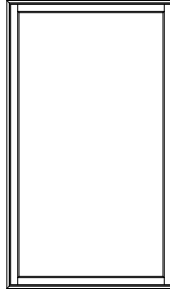

ECAP4272

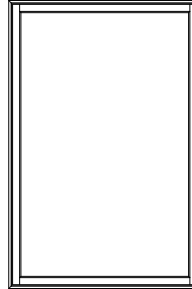

ECAP4872

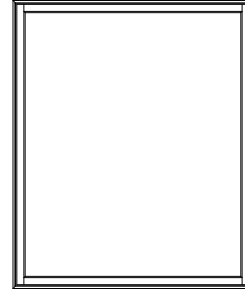

ECAP6072

ELEVATION SYMBOL LEGEND:

M.O. = MASONRY OPENING
VALUES IN () ARE IN MILLIMETER CONVERSIONS

Note: Elevations shown DO NOT have exterior trim. Subtract 1/2" (12.7) from M.O. (Masonry Opening) for Unit Sizes. Masonry Openings above include Sill Nose, see Trim Options page for Sill Nose specifications. For other Trim Options refer to the Unit Sizing, Rough Opening & Masonry Openings page.

SCALE 1/4" = 1'

PICTURE UNITS

M.O. BRICKMOULD
M.O. ADAMS/FLAT CASING
ROUGH OPENING
FRAME SIZE
DAYLIGHT OPENING

75 1/2"(1918)
78 1/2"(1994)
72 3/4"(1848)
72"(1829)
66 3/32"(1679)

38 5/16"(973)
39 13/16"(1011)
36 3/4"(933)
36"(914)
30 3/32"(764)



ECAP7236

44 5/16"(1126)
45 13/16"(1164)
42 3/4"(1086)
42"(1067)
39 3/32"(993)



ECAP7242

50 5/16"(1278)
51 13/16"(1316)
48 3/4"(1238)
48"(1219)
45 3/32"(1145)

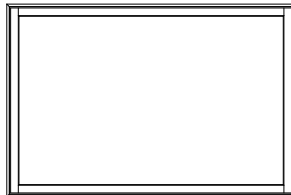

ECAP7248

56 5/16"(1430)
57 13/16"(1468)
54 3/4"(1391)
54"(1372)
48 3/32"(1222)

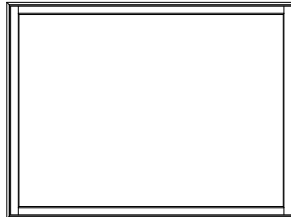

ECAP7254

62 5/16"(1583)
63 13/16"(1621)
60 3/4"(1543)
60"(1524)
54 3/32"(1374)

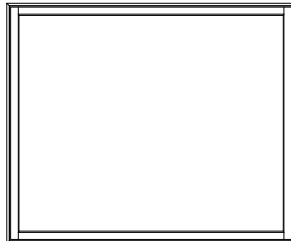

ECAP7260

68 5/16"(1735)
69 13/16"(1773)
66 3/4"(1695)
66"(1676)
60 3/32"(1526)

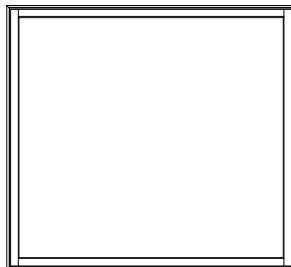

ECAP7266

M.O. BRICKMOULD
M.O. ADAMS/FLAT CASING
ROUGH OPENING
FRAME SIZE
DAYLIGHT OPENING

75 1/2"(1918)
78 1/2"(1994)
72 3/4"(1848)
72"(1829)
66 3/32"(1679)

74 5/16"(1888)
75 13/16"(1926)
72 3/4"(1848)
72"(1829)
66 3/32"(1679)

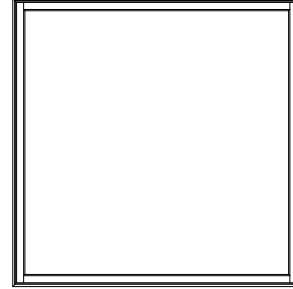

ECAP7272

ELEVATION SYMBOL LEGEND:

M.O. = MASONRY OPENING
VALUES IN () ARE IN MILLIMETER CONVERSIONS

Note: Elevations shown DO NOT have exterior trim. Subtract 1/2" (12.7) from M.O. (Masonry Opening) for Unit Sizes. Masonry Openings above include Sill Nose, see Trim Options page for Sill Nose specifications. For other Trim Options refer to the Unit Sizing, Rough Opening & Masonry Openings page.

SCALE 1/4" = 1'

SASH GLAZING OPTIONS

INTERIOR GLAZING OPTIONS

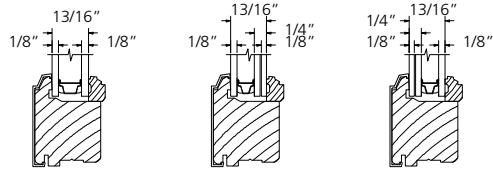

**AWNING &
PICTURE**
5/DS//5/DS

**AWNING &
PICTURE**
5/DS//7.0L

**AWNING &
PICTURE**
7.0L//5/DS

SCALE 3" = 1'

DIRECT SET GLAZING OPTIONS

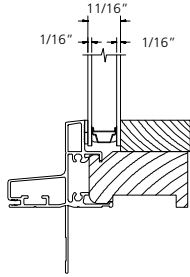

STANDARD INSULATED GLASS

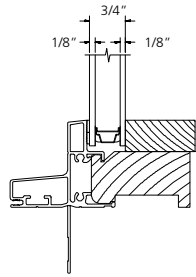

STANDARD INSULATED GLASS

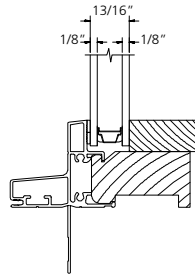

STANDARD INSULATED GLASS

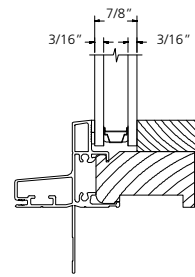

STANDARD INSULATED GLASS

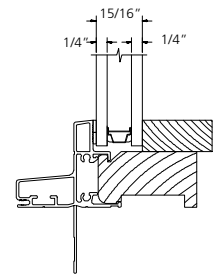

STANDARD INSULATED GLASS

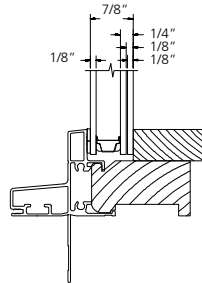

LAMINATED INSULATED CLEAR OR LOW E GLASS

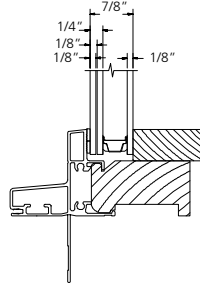

LAMINATED INSULATED TINTED GLASS

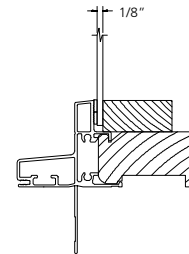

LAMINATED INSULATED SINGLE GLASS

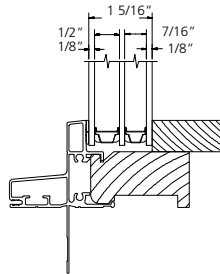

DS TRIPANE INSULATED GLASS

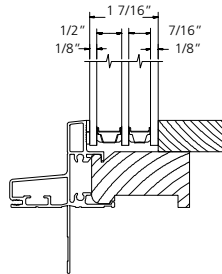

5/32" TRIPANE INSULATED GLASS

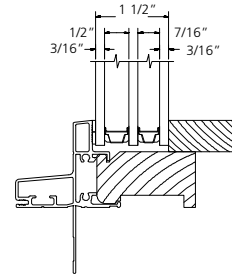

3/16" TRIPANE INSULATED GLASS

Notes:

GLAZING OPTIONS SHOWN ARE AVAILABLE IN CLAD GEOMETRIC DIRECT SET WINDOWS WITH FRAME AS SHOWN AND ALSO IN CLAD RADIUS DIRECT GLAZED WINDOWS AND WOOD GEOMETRIC AND RADIUS DIRECT GLAZED WINDOWS. SEE DRAWING EXCladRadiusDSet FOR CLAD RADIUS WINDOW FRAME AND DRAWING EXWoodDirectSet FOR WOOD GEOMETRIC AND RADIUS FRAME DETAILS.

DUAL PANE AND TRI PANE IG SHOWN WITH STAINLESS STEEL WARM EDGE SPACER MAY ALSO BE BUILT WITH ALUMINUM BOX SPACER DEPENDING ON SHAPE, GLASS TYPE, OR SPECIAL GRILLE BAR PATTERN.

TRIM OPTIONS

EXTERIOR TRIM

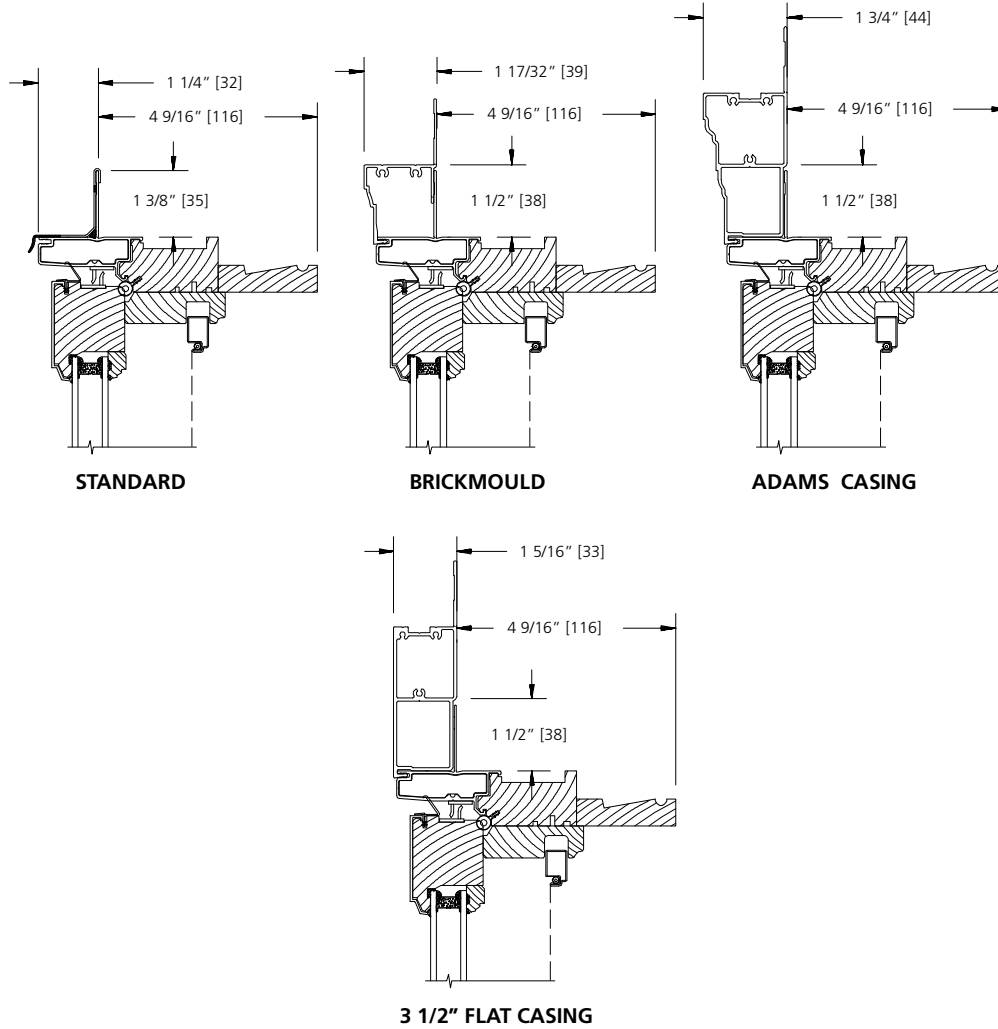

SILL NOSE OPTIONS

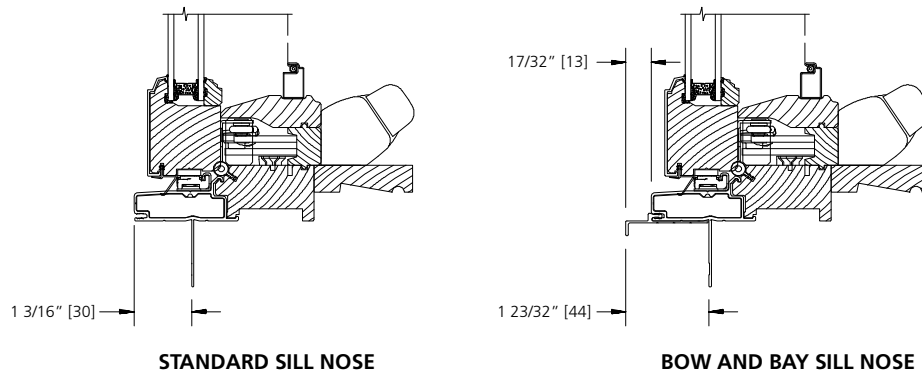

SCALE: 3" = 1'

JAMB EXTENDER OPTIONS

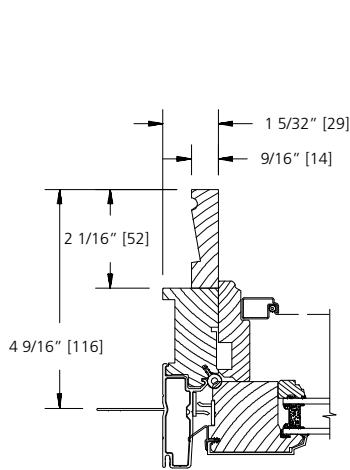

4 9/16" WALL
9/16" JAMB THICKNESS (OPTION)

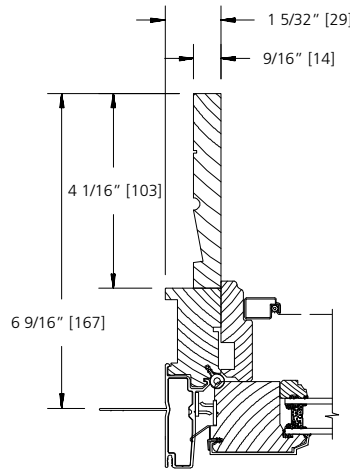

6 9/16" WALL

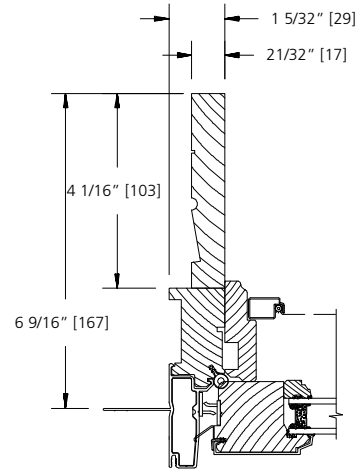

6 9/16" WALL
4/4 JAMB THICKNESS (STANDARD)

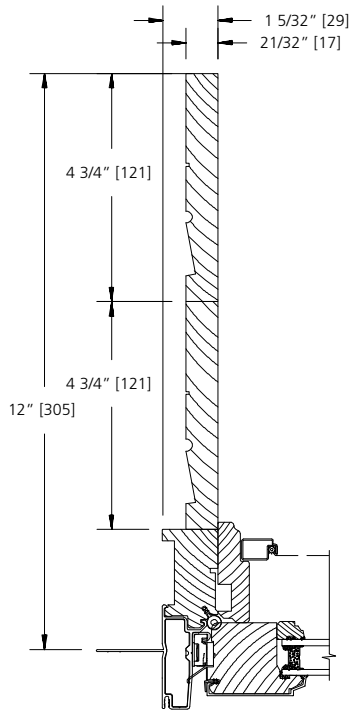

12" WALL
4/4 JAMB THICKNESS (STANDARD)
2 PC JAMB EXTENSION SHOWN

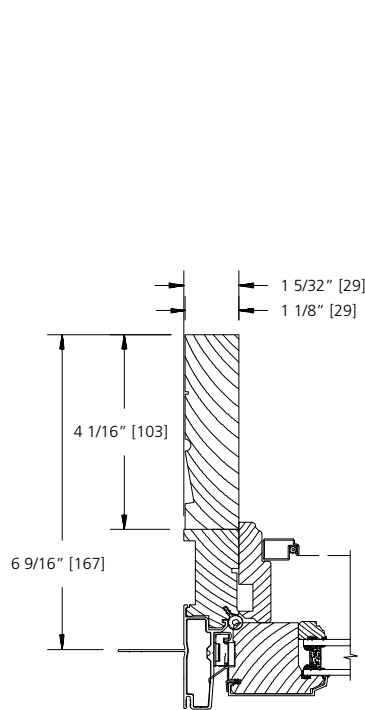

6 9/16" WALL
5/4 JAMB THICKNESS (OPTION)

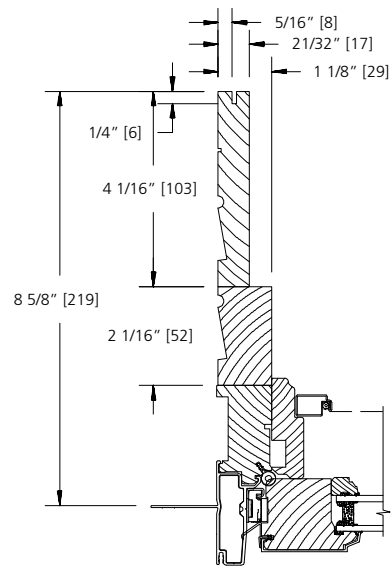

8 5/8" WALL
5/4-4/4 STACKED KERFED
JAMB OPTION

Notes:

Jamb Extension (9/16" thick) only available on jambs up to 6-9/16".
Jambs over 6-9/16" will only have a 4/4 or 5/4 option.
Jambs over 7-1/4" up to 12" will be 2 layers.
Kerfed Jamb Extension only available on 4/4 or 5/4 options.

SCALE: 3" = 1'

STANDARD MULLION OPTIONS

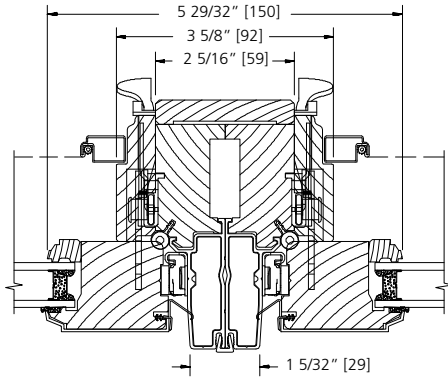

TWIN AWNING

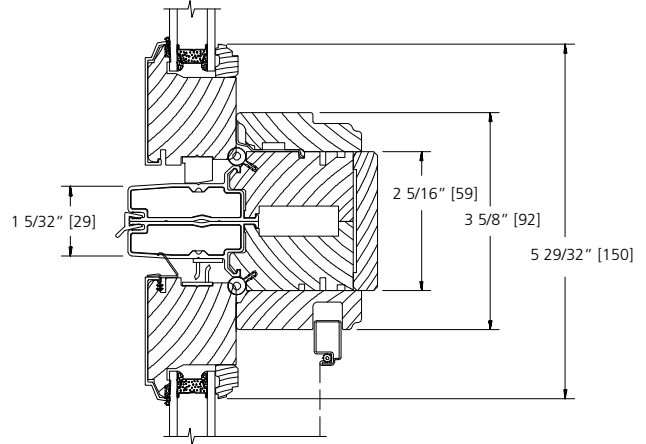

**OPERATING AWNING WITH
FIXED TRANSOM**

LITE CUT INFORMATION

Clad awning windows are available with removable grilles in 7/8", 1-1/8" and 1-3/8" widths, Airspace (between the panes) grilles, and Simulated Divided Lites. Standard lite cuts are rectangular.

LITE CUT OPTIONS

Special lite cut patterns can include a wide variety of straight line and radius patterns. The illustrations shown here represent just a few of the possibilities. Rectangular, horizontal, vertical and Prairie lite patterns are available in all standard size clad casement windows. Uneven, diamond, radius and Gothic lite cuts are available, subject to approval. Approvals are based on the ability to fulfill the design requirement while maintaining the construction integrity of the finished product.

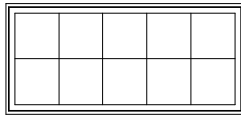

RECTANGULAR

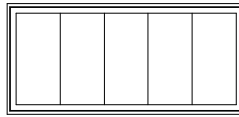

VERTICAL

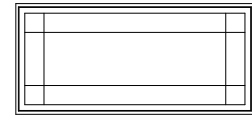

PRAIRIE

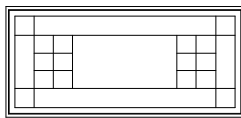

UNEVEN

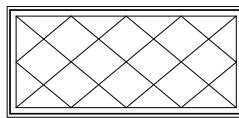

DIAMOND

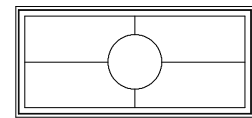

RADIUS

BAR ALIGNMENT

Alignment of divided lite muntin bars from one window to the next is often required by fine architectural design. Wood grilles, Airspace grilles, and Simulated Divided Lites may be specified with muntin bars aligned.

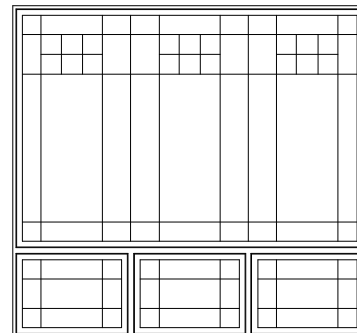

DIVIDED LITE OPTIONS

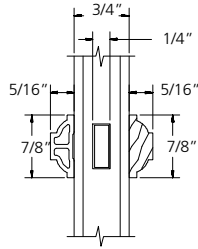

7/8" SDL

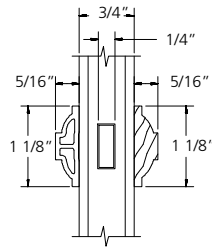

1 1/8" SDL

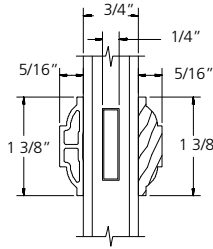

1 3/8" SDL

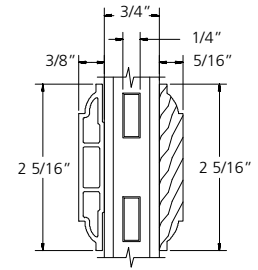

2 5/16" SDL

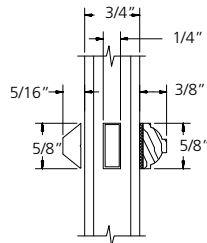

5/8" PUTTY/BEAD SDL

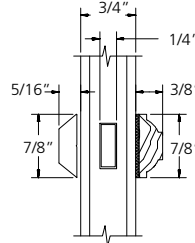

7/8" PUTTY/BEAD SDL

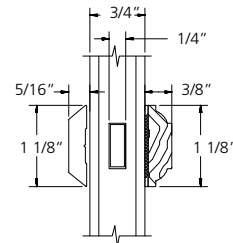

1 1/8" PUTTY/BEAD SDL

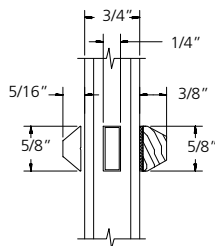

5/8" PUTTY/PUTTY SDL

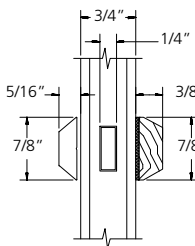

7/8" PUTTY/PUTTY SDL

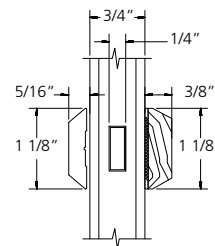

1 1/8" PUTTY/PUTTY SDL

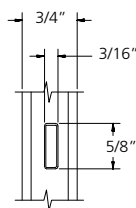

5/8" GRILLE

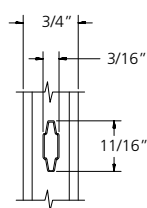

23/32" GRILLE

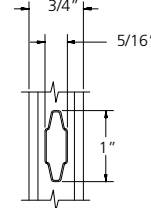

1" GRILLE

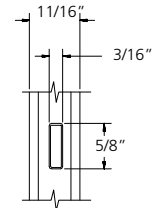

5/8" GRILLE

GRILLES MEETING

NFRC 3mm RULE

GRILLE PROFILES:

3/16" x 5/8"	ALLMETAL 1021101018XX140
3/16" x 1"	ALLMETAL 1020101018XX164
1/4" x 5/8"	ALLMETAL 1020102018XX140
1/4" x 1"	ALLMETAL 1020102018XX164
5.5mm x 18mm CONTOUR	ALLMETAL 1020301010XX255
8mm x 25mm CONTOUR	ALLMETAL 1020301018XX380

SCALE: NTS

DIRECT SET DIVIDED LITE OPTIONS

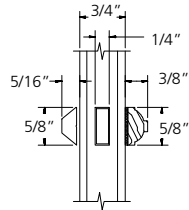

5/8" PUTTY/BEAD SDL

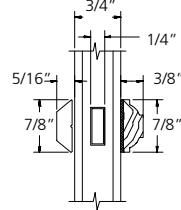

7/8" PUTTY/BEAD SDL

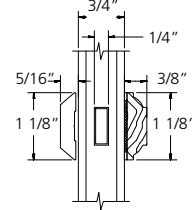

1 1/8" PUTTY/BEAD SDL

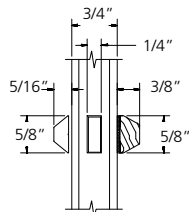

5/8" PUTTY/PUTTY SDL

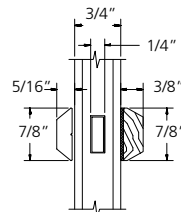

7/8" PUTTY/PUTTY SDL

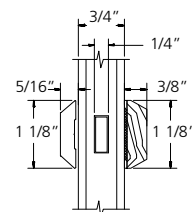

1 1/8" PUTTY/PUTTY SDL

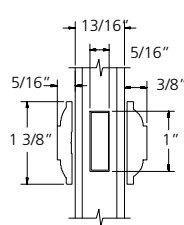

1 3/8" SDL

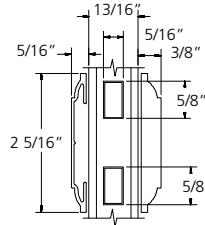

2 5/16" SDL

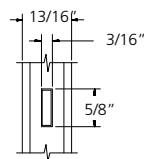

5/8" GRILLE

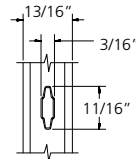

23/32" GRILLE

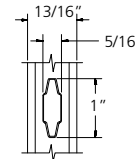

1" GRILLE

GRILLES MEETING

NFRC 3mm RULE

GRILLE PROFILES:

- 3/16" X 5/8" ALLMETAL 1021101018XX140
- 3/16" X 5/8" ALLMETAL 1021101018XX140
- 1/4" X 5/8" ALLMETAL 1020102018XX140
- 1/4" X 1" ALLMETAL 1020102018XX164
- .325" X 5/8" ALLMETAL 1020106018XX140
- .325" X 1" ALLMETAL 1020106018XX164
- 5.5mm X 18mm CONTOUR ALLMETAL 1020301010XX255
- 8mm X 25mm CONTOUR ALLMETAL 1020301018XX380

SCALE: NTS

VENT PROJECTIONS

NARROW OPERATOR
Frame Width under 21"

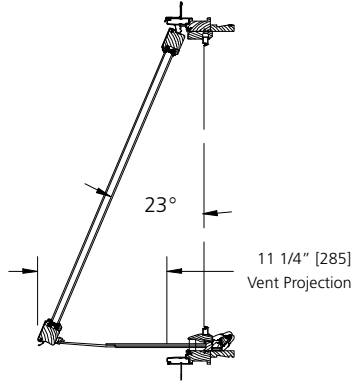

Roto type hardware

STANDARD OPERATOR
Frame Width 21" and over

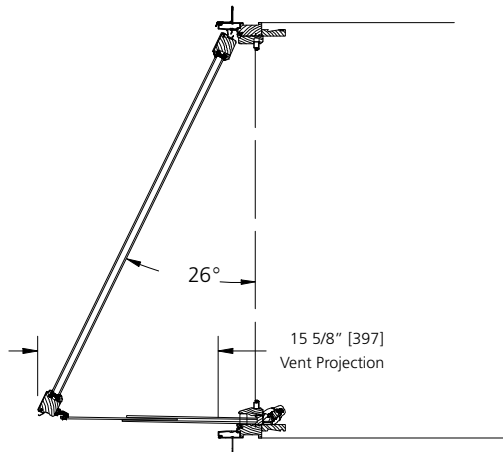

Roto type hardware

AWNING VENT PROJECTION

The drawings above reflect full operation. Dimensions and angles above are approximate and will vary due to frame height.

**UNIT SIZING, ROUGH OPENINGS
& MASONRY OPENINGS**

STANDARD OFFERING

DRIP CAP & NAILING FLANGE

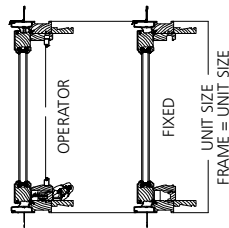
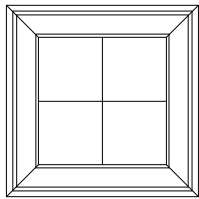
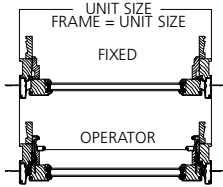

GENERAL NOTES:

UNITS WITH NO TRIM AND SILL NOSE:
UNIT SIZE = FRAME SIZE

UNIT SIZE IS ALWAYS THE
EXTREME SIZE OF THE WINDOW
WITH OR WITHOUT TRIM
(DRIP CAP & NAILING FLANGE ARE
NOT ADDED TO ANY UNIT SIZING)

MASONRY OPENING:
MASONRY OPENING IS ALWAYS 1/2" OVER
THE UNIT SIZE OF THE WINDOW

ROUGH OPENING:

ROUGH OPENING IS ALWAYS 3/4" OVER
FRAME SIZE OF THE WINDOW

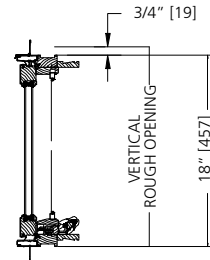
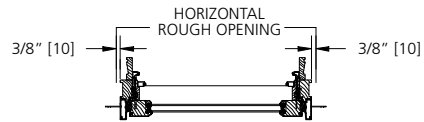

NON-STANDARD UNIT SIZING

EXTERIOR TRIM OFFERINGS WITH SILL NOSE

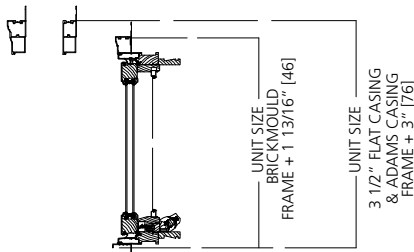

EXTERIOR TRIM OFFERINGS WITHOUT SILL NOSE
EXTERIOR TRIM ON ALL 4 SIDES

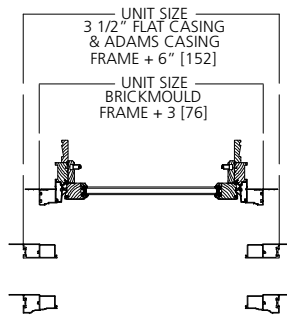
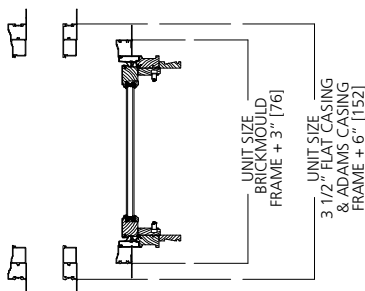

HORIZONTAL SECTION
TRIM OFFERINGS
ABOVE ARE THE SAME
WITH OR WITHOUT SILL NOSE

**FRAME TO TRIM
DIMENSIONS**

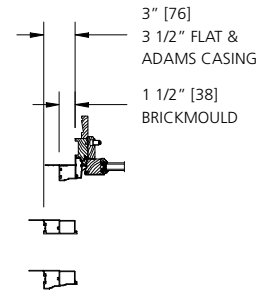

TYPICAL FOR HEAD, SILL & SIDE

1-WIDE UNIT

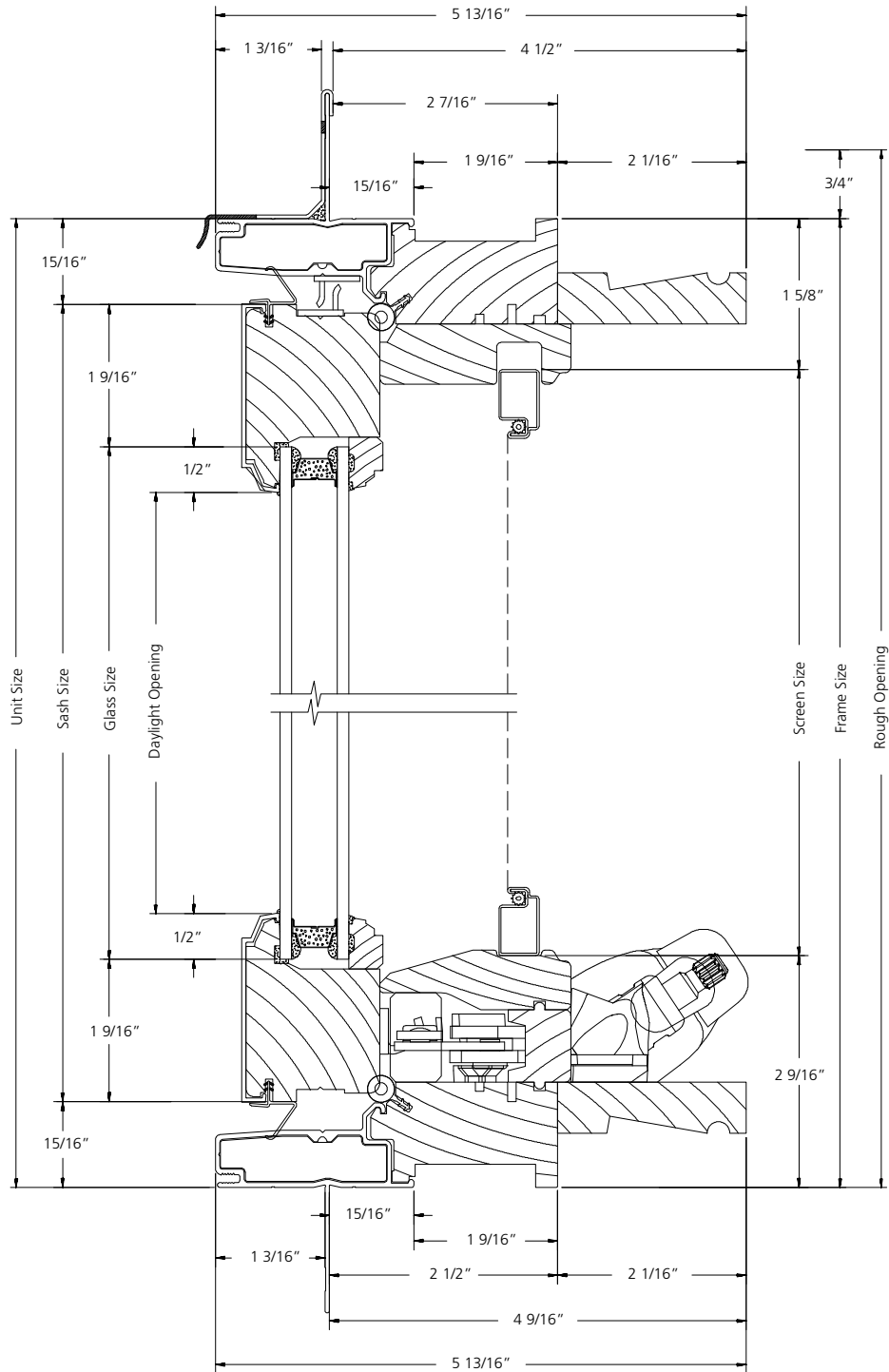

VERTICAL SECTION

SCALE: 6" = 1'

1-WIDE UNIT

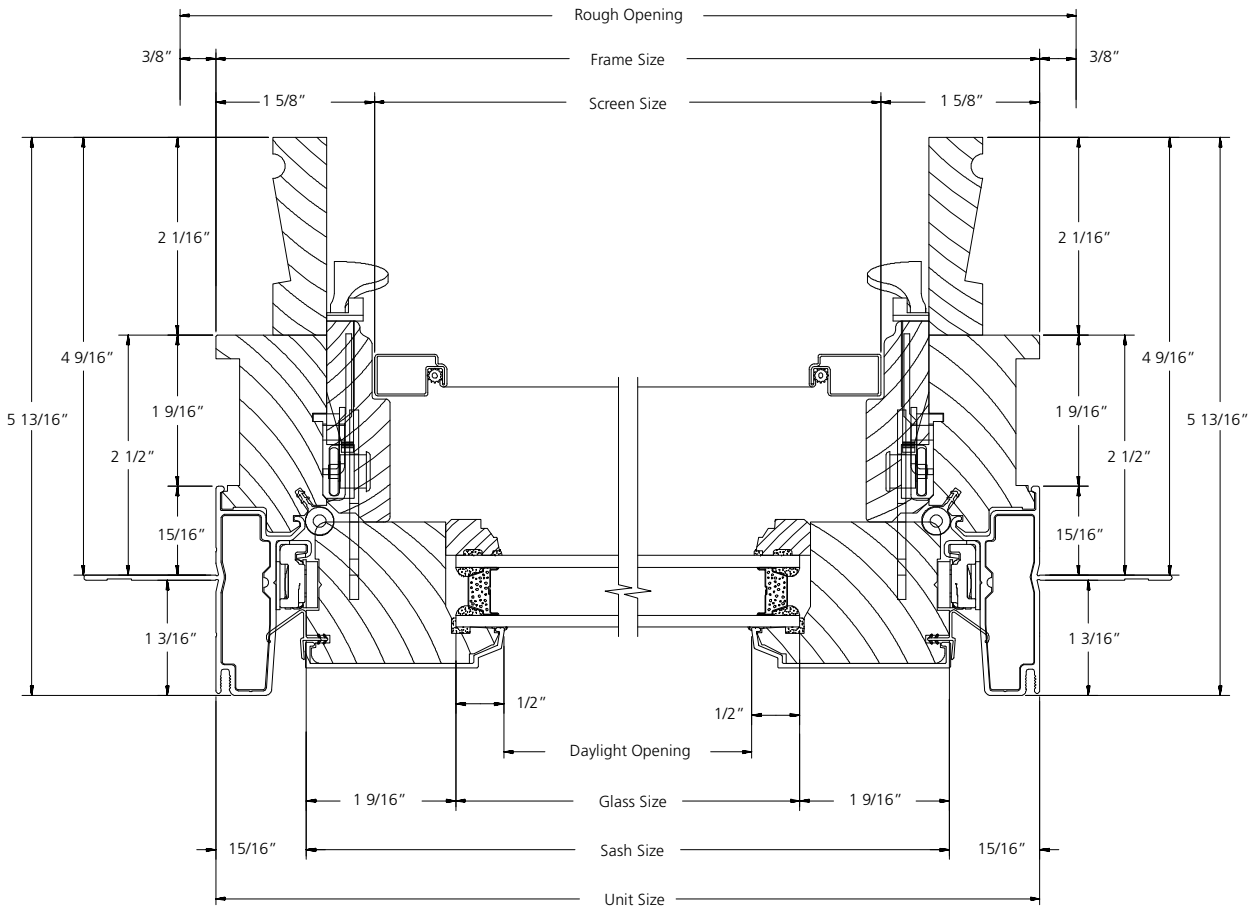

HORIZONTAL SECTION

SCALE: 6" = 1'

PICTURE UNIT

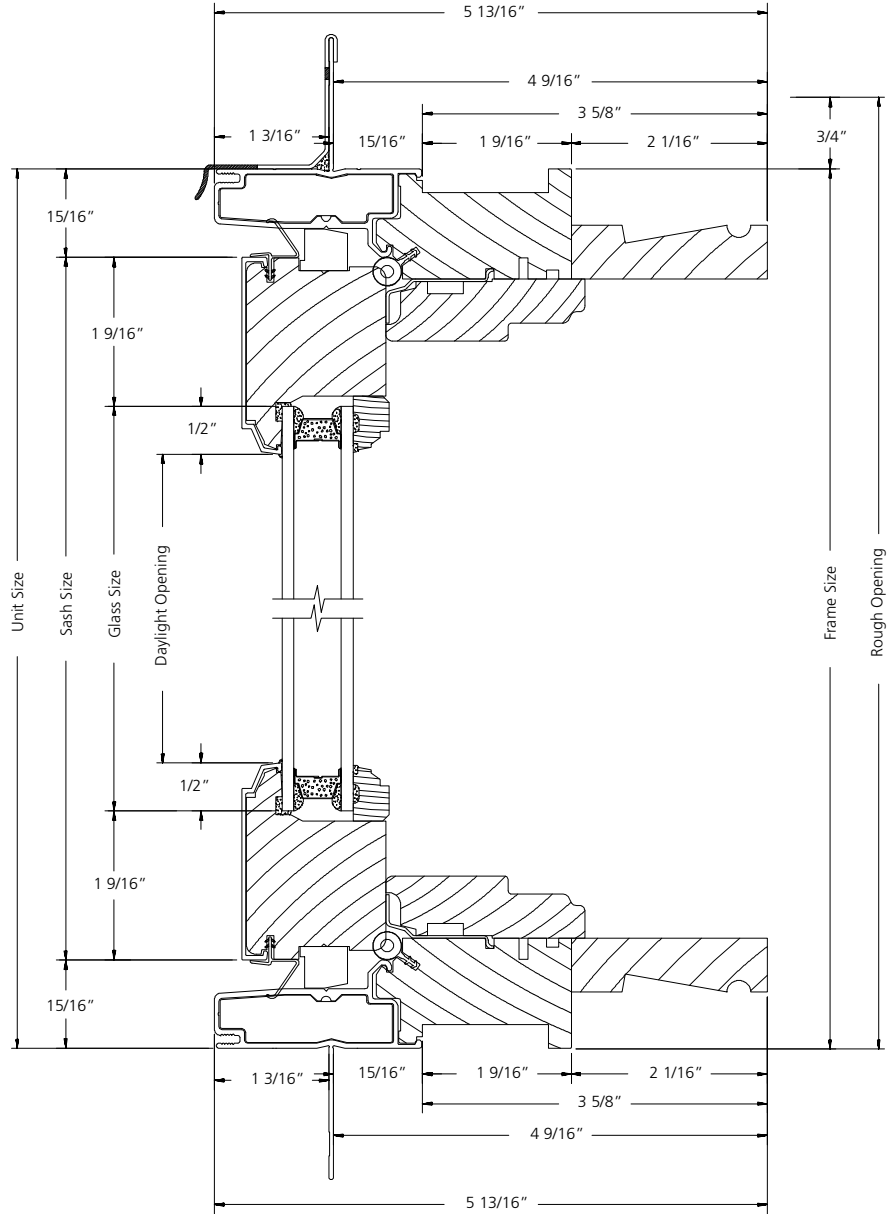

VERTICAL SECTION

SCALE: 6" = 1'

PICTURE UNIT

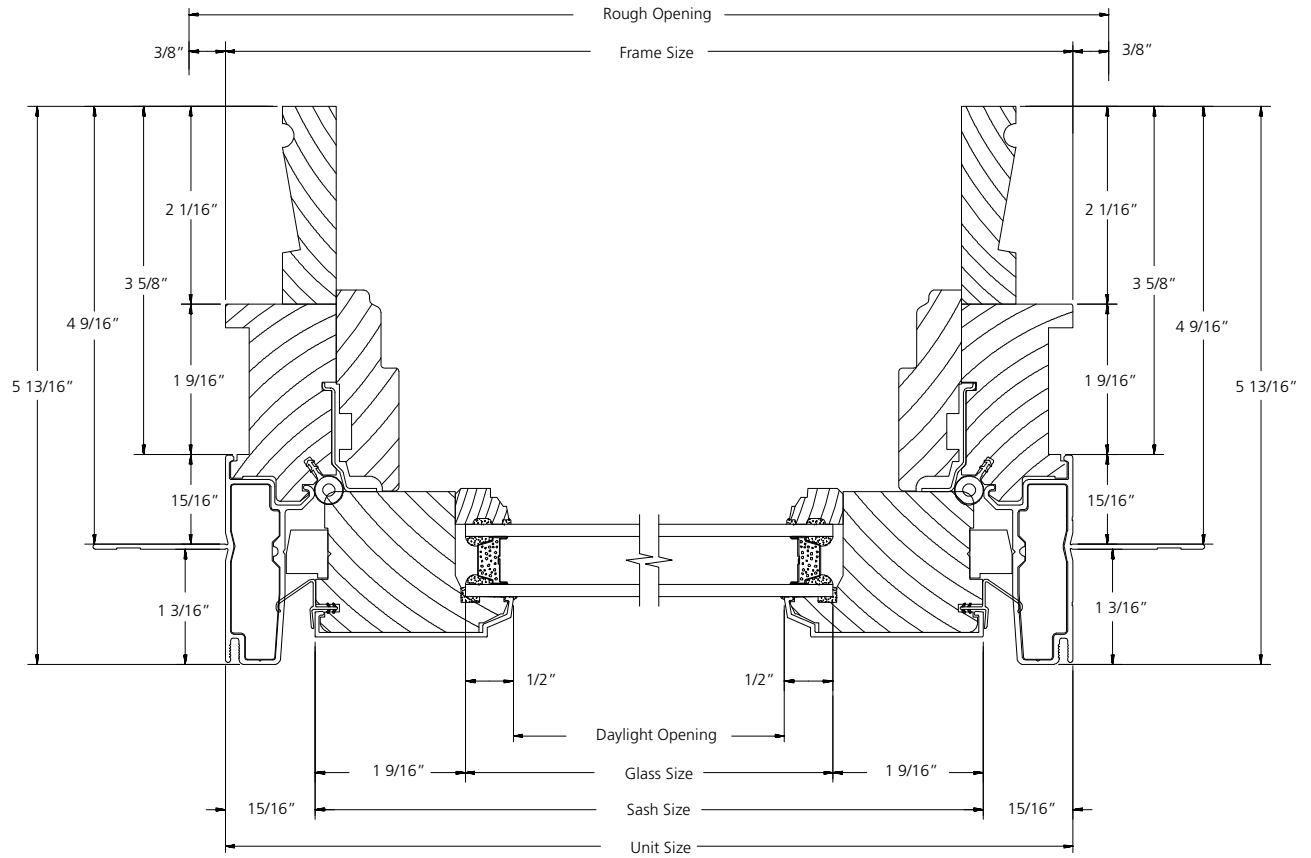

HORIZONTAL SECTION

SCALE: 6" = 1'