



This guide contains procedures for common user serviceable repair tasks found on aluminum casement and awning windows. If a condition arises that is not covered in this guide, please contact us for professional help. This product guide covers our current JELD-WEN windows as well as our historical products with the following names: Seasonshield, Windowmaster, Wenco and Summit. For help identifying your window model, refer to your product purchase paperwork or call us for additional help.

Do-It-Yourself

Technician



## INTRODUCTION

Casement windows consist of one sash that opens and closes like a door (options also include multiple sashes such as a fixed sash mullered to an operating sash). Awning windows open from the bottom and hinge at the top. An insect screen is mounted on the interior side of operating sashes.

### CONTACT US

For questions, feel free to contact us by phone or email:

- Phone: 1-(800)-JELD-WEN/1-(800)-535-3936
- Email: customerserviceagents@jeld-wen.com

### TABLE OF CONTENTS

Precautions and Safety .....	2
Needed Materials & Tools .....	2
Sash Removal & Installation .....	2
Hardware Replacement & Adjustment	
Casement Operator Removal & Installation .....	3
Awning Operator Removal & Installation .....	4
Casement Hinge Adjustment .....	4
Hinge Replacement .....	5
Single Point Lock Replacement .....	5
Multi-Point Lock Replacement .....	5
Proper Window Installation .....	6
Troubleshooting Operational Problems .....	7
Glossary .....	9

## CASEMENT WINDOW ANATOMY

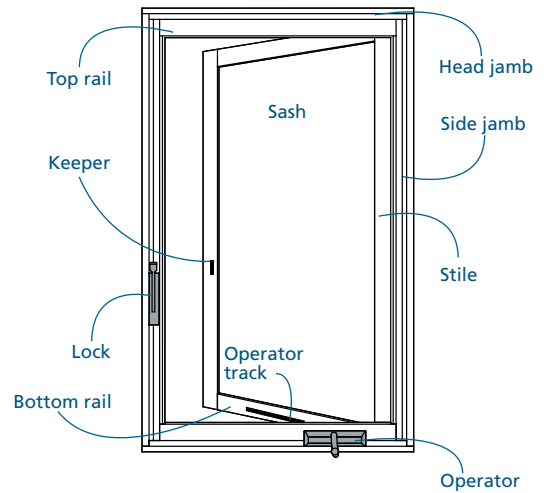

## AWNING WINDOW ANATOMY

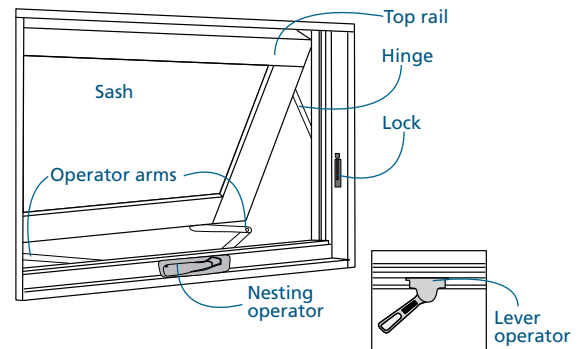

The advice offered herein can be done by a homeowner with some mechanical aptitude. If you are unsure, it is recommended that you hire a trained service provider such as a competent and licensed construction contractor or building professional. JELD-WEN disclaims any and all liability associated with the use and/or provision of these instructions. Any reliance upon the information or advice is at the risk of the party so relying. The information contained herein may be changed from time to time without notification.

## PRECAUTIONS & SAFETY

- Follow all manufacturers' instructions and labels.
- Use proper and safe equipment and precautions if servicing the exterior side of windows above ground level.
- Window insect screens are not security devices and will not prevent children, other people, or pets from falling through.
- Use extra care when driving screws near glass unit to avoid breakage.
- Use caution when tightening screws to avoid stripping the screw holes.
- Sashes may be very heavy and removal can be awkward and could cause physical injury or product damage; we recommend the help of a second person.
- Beware of oil causing slippery surfaces.

## NEEDED TOOLS & MATERIALS

### NEEDED TOOLS

**Note!** Each tool is not required for every task.

- Tape measure
- Level
- Flat head screwdriver
- Phillips head screwdriver

### NEEDED MATERIALS

- String
- Tape

## SASH REMOVAL & INSTALLATION

### CASEMENT SASH

There are two types of casement sashes: operating and fixed, or fastened to the window frame and does not open. An operating sash opens from one side on hinges. Handing is determined by the hinge location as viewed from the exterior. For replacement of a fixed sash, call us for assistance.

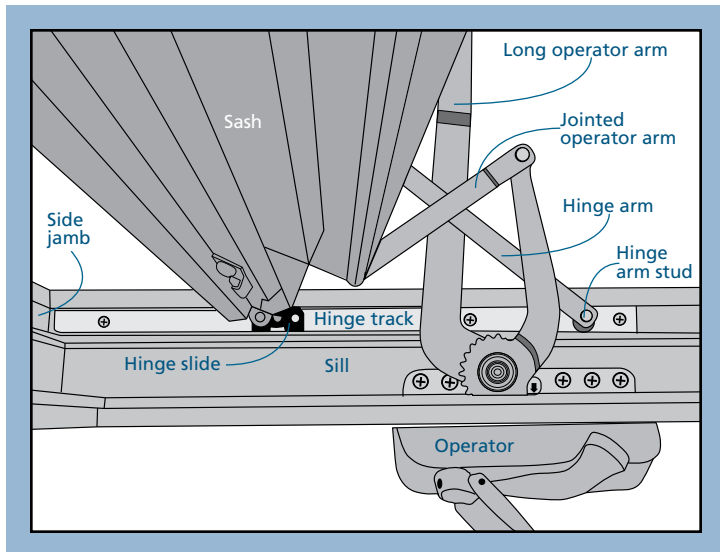

### REMOVAL

1. Remove insect screen from window (if present).
2. Unlock and open sash at least half way.
3. Disconnect operator from sash as follows:

**Note:** Windows may have a dual-arm operator (shown) or a single-arm operator. To remove a single-arm operator, skip the instructions for Jointed Operator Arm and begin with Long Operator Arm.

### Jointed Operator Arm

1. If the jointed operator arm has a retaining clip, pull the clip off of the stud on the sash.
2. Depress the jointed operator arm at the sash with a flat head screwdriver and remove from the stud.

### Long Operator Arm

1. Some older windows have a notch underneath the bottom rail of the sash. If the window has this notch, position the end of the long operator arm to line up with the notch.
2. Depress operator arm with a flat head screwdriver and disengage from the sash.
3. Push sash fully open.
4. Crank operator to the closed position to move arms out of the way.
5. Securely grip the sash. A second person may be needed.
6. If the hinge arm has a retaining clip, pull the clip off of the hinge arm stud on the frame.
7. Pry hinge arm off of the hinge track stud at bottom, then top of window (in that order) with a flat head screwdriver. At this point, hinge arms should be loose. Securely hold the sash to keep it from falling.
8. Slide sash toward the center of window to disengage from both upper and lower hinge tracks.
9. Slightly tilt sash and remove.

### INSTALLATION

1. Firmly grip sash.
2. Engage hinge slides into upper and lower hinge tracks at the same time.
3. Slide sash toward the side jamb.

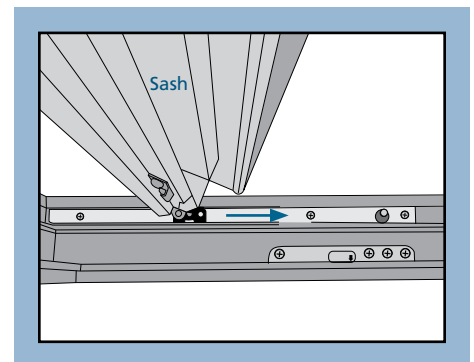

--Continued

## SASH REMOVAL & INSTALLATION - CONTINUED

### CASEMENT SASH - CONTINUED

4. Make sure top and bottom hinge slides are fully engaged before continuing.
5. Snap the hinge arm onto the hinge track stud at the head jamb, then the sill.
6. Attach the end of the jointed operator arm to the corner of the sash and engage the retaining clip (if applicable).
7. For windows with a notch under the sill, position the sash so the end of the long operator arm engages (snaps) into the notch.
8. Test for proper operator attachment by cranking the operator open and closed.
9. Replace the insect screen (if present) and verify the lock operates properly.

### AWNING SASH

#### REMOVAL

1. Unlock and open sash.
2. Locate the retainer clips at the end of the operator arms where they connect to the sash.
3. Slide the clips away from the sash, off of each stud.
4. Hold the sash firmly and remove operator arms from studs.

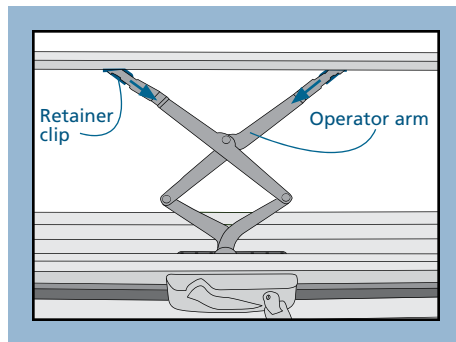

5. Locate the clip at the jamb end of each hinge arm.
6. Slide the clips toward the sash, off of the stud.
7. Hold the sash firmly and remove hinge arms from each stud. The sash will now be completely unsupported.
8. The sash can now be slid down until the hinge slides come out of the hinge track.

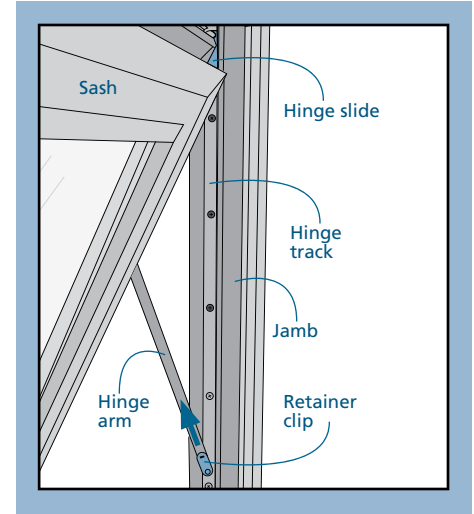

#### INSTALLATION

1. Firmly grip sash.
2. Engage hinge slides into both sides at the same time.
3. Slide sash upward toward the top.
4. Install the hinge arms onto the studs and slide the clips back onto the studs.
5. Install operator arms onto the studs on the sash and reattach the clips to the studs.
6. Test for proper operator attachment by cranking the operator open and closed.
7. Replace the insect screen (if present) and verify the lock operates properly.

## HARDWARE REPLACEMENT & ADJUSTMENT

### OPERATOR REPLACEMENT - REMOVE HANDLE FOR ALL WINDOWS

1. Remove insect screen from window (if present).
2. Open the window half way.
  - If there is a small set screw on the side of the handle, use a small flat head screwdriver to loosen it to allow removal of the handle.
  - If there is no set screw, the handle is attached with a spring clip and can be removed simply by pulling it off with a slight tug.
3. Remove the handle.
4. Grip the operator cover on both sides and lift up from underneath to remove (some operator covers are not removable and are removed through a hole in the frame).

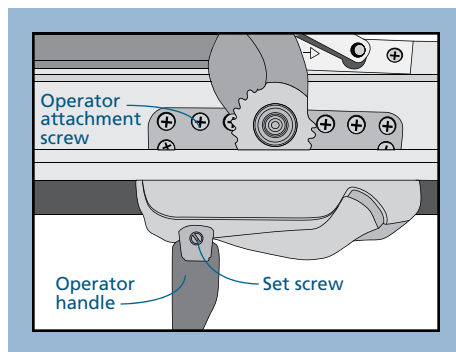

### CASEMENT OPERATOR REMOVAL & INSTALLATION

Dual-arm casement operators have the jointed operator arm, while single-arm operators do not.

#### REMOVAL

1. Follow the steps to remove the operator arm(s) listed in "Sash Removal & Installation."
2. Remove the screws holding the operator to the sill with a Phillips screwdriver.
3. Remove the operator to the interior.

**Note!** On some windows, there is a gasket under the operator. Remove carefully to avoid damage. Re-use the gasket under the replacement operator.

#### INSTALLATION

1. Replace the gasket under the operator (if applicable).
2. Reposition operator in hole and reinstall screws (do not over tighten).
3. Reattach the jointed operator arm and the long operator arm to the sash.
4. Test operator by opening and closing sash. Remove and replace if necessary.
5. Reinstall insect screen if applicable.

HARDWARE REPLACEMENT & ADJUSTMENT - CONTINUED

**AWNING OPERATOR REMOVAL & INSTALLATION**

**REMOVAL**

1. Unlock and open sash.
2. Locate retainer clips at the end of the operator arms where they connect to the sash.
3. Slide the clips away from the sash and off of each stud.
4. Support the sash and remove operator arms from studs.
5. Remove the screws holding the operator to the sill with a Phillips screwdriver.
6. Remove the operator to the interior.

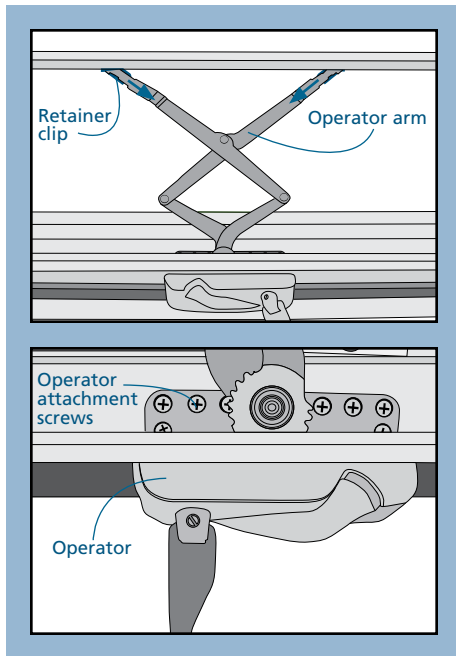

**Note!** On some windows, there is a gasket under the operator. Remove carefully to avoid damage. Re-use the gasket under the replacement operator.

**INSTALLATION**

1. Replace the gasket under the operator (if applicable).
2. Reposition operator in hole and reinstall screws (do not over tighten).
3. Install operator arms onto the studs on the sash and reattach the clips to the studs.
4. Test for proper operator attachment by cranking the operator open and closed.
5. Replace the insect screen (if present) and verify the lock operates properly.

**CASEMENT HINGE ADJUSTMENT**

If the sash is dragging on the sill or does not fit squarely or flush inside the frame, adjustment is necessary. This is possible if the hinge on the sill underneath the window is adjustable. Awning window hinges are not adjustable. Some casement window hinges are adjustable, determine as follows:

**NON - ADJUSTABLE HINGES**

A non-adjustable hinge has a retaining clip attached to the hinge arm. Call a service technician for help with non-adjustable hinges.

**ADJUSTABLE HINGES**

A hinge without a retaining clip is adjustable. The hinge arm stud, underneath the hinge arm, can be shifted with either a 3/8" open-end wrench, or an adjustment wrench (available from our service department).

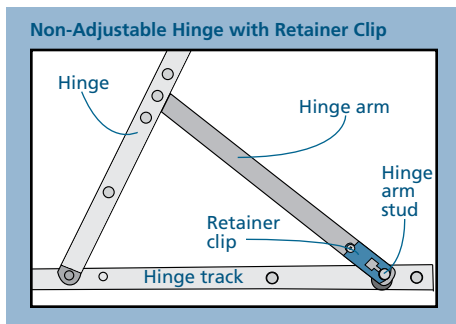

1. Open the window completely.
2. If using an adjustment wrench, it will fit between the hinge arm and hinge track and is not necessary to remove the hinge arm from the stud.
3. If using a 3/8" open-end wrench, gently pry the hinge arm from hinge arm stud with a flat head screwdriver.
4. Adjust hinge arm stud:
  - to raise the outer edge of the sash, turn the stud away from the lock side of the window
  - to lower the outer edge of the sash, turn the stud toward the lock side of the window.
5. Maximum sash adjustment is reached when the flat sides of the stud are parallel to the hinge track. Turning the stud beyond parallel will not increase sash correction.
6. Close and open the sash to test adjustment.

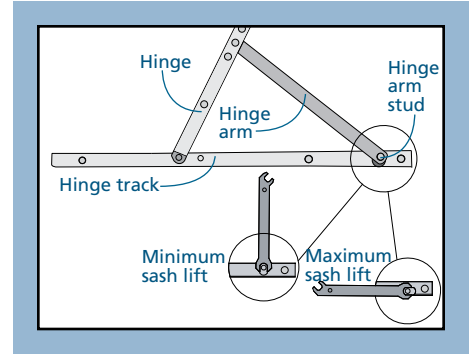

- If outer edge of the sash needs lifting, adjust hinge arm stud at the top of the sash by turning the stud toward the lock side of the window.
- If sash needs further lifting, a sash lift button or riser block may be an option. Many windows already have these installed. If the window does not have a lift button or riser block, call a supplier or our service department for availability. Insert sash lift button into sash button hole, or install the riser block as shown. This will lift the sash when it is closed.

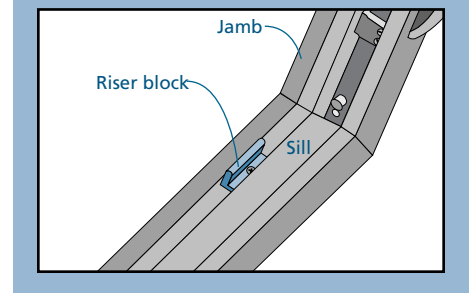
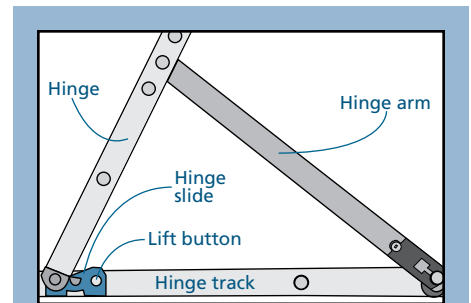

- If the outer edge of the sash needs to be lowered further, adjust hinge arm stud at the top of the sash by turning the stud away from the lock side of the window.

HARDWARE REPLACEMENT & ADJUSTMENT - CONTINUED

**HINGE REPLACEMENT - ALL WINDOWS**

Casement hinges are located at the top and bottom of the sash and allow the window to open and close. Handing is determined by the hinge location as viewed from the exterior. Hinges are either left or right-handed. If a window has left-handed operation, the bottom hinge will be a left-handed hinge, and the top hinge will be a right-handed hinge. Awning hinges are located on each side.

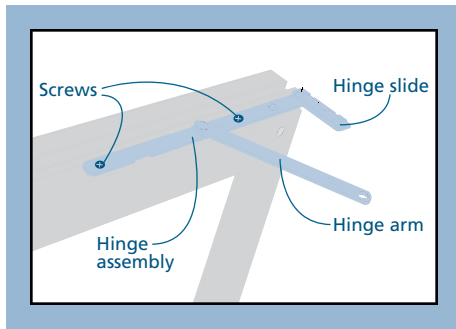

**Note!** Before beginning replacement, compare replacement hinge to the existing hinge to make sure it is the correct type and handing.

1. Remove sash.
2. Remove old hinge:
  - Fold operator/hinge arm(s) out of the way.
  - Unscrew and remove hinge track.
  - Unscrew and remove hinge assembly.
3. Install the hinge track and the new hinge assembly. Do not over tighten screws and strip screw holes.
4. Reinstall sash and check operation.

**SINGLE - POINT LOCK & KEEPER REPLACEMENT**

**LOCK REMOVAL**

1. Unlock and open window approximately 4".
2. Unscrew and remove lock.

**Note!** A 42" or smaller casement window may have one lock. Larger windows may have multiple locks on the same side. Awning windows will have a lock on both sides.

**LOCK INSTALLATION**

1. Slide replacement lock into existing groove.
2. Replace screws.
3. Close and lock window.

**KEEPER REPLACEMENT**

1. Some keepers may look different. Always install the new keeper in the same place and facing the same direction as the old keeper.
2. Remove screws and keeper.
3. Install new keeper on sash in the same location and direction as the old keeper (open side of keeper should face sash edge).

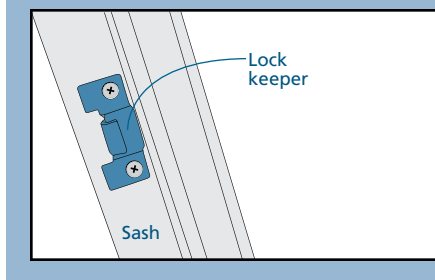
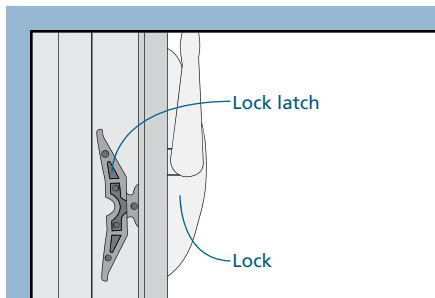

**MULTI - POINT LOCK REPLACEMENT - CASEMENT WINDOWS ONLY**

**LOCK REMOVAL**

1. Remove the screen.
2. Open the window half way.
3. Unscrew and remove the latch assembly.
4. Locate the locking mechanism and the holding guides in the side jamb of the window.
5. Hold onto the locking mechanism, unscrew and remove the guides. Remove the locking mechanism.

**LOCK INSTALLATION**

1. Position the locking mechanism in the jamb.
2. Secure each guide.
3. Insert the latch assembly and secure with screws.
4. Replace the screen if applicable and test operation by closing and locking the sash.

**KEEPER REPLACEMENT**

1. Remove the screen.
2. Open the window half way.
3. Locate the lock keepers on the sash edge. The number of keepers varies depending on the size of the unit.
4. Unscrew and remove the keeper(s).
5. Replace the new keeper(s) in the exact position as the old one, using the same screws. Do not over tighten screws and strip holes.

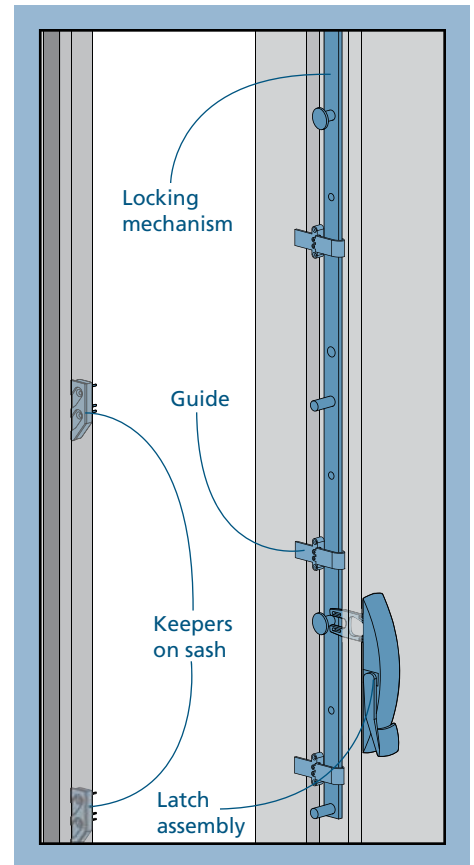

## PROPER WINDOW INSTALLATION

- Proper installation is essential for keeping windows operating smoothly. If a window fails to operate properly, an inspection is necessary to determine if it was installed correctly.
- These inspection instructions apply to flat window types. Bow windows, bay windows, and unusual geometric-shaped windows are more complicated and should be inspected by a window professional.
- A contractor or installer can assist in determining the cause of a window being “out of specification” and possibly correct it. Window problems due to improper installation are usually not covered by the manufacturer’s warranty. For installation instructions, contact us or your supplier.
- The specifications and measurements referenced in this guide are taken from ASTM E2112 Standard Practice for Installation of Exterior Windows, Doors and Skylights.

**Note:** These instructions do not address inspection for proper “water tightness” or flashing. A “water tight” inspection requires removal of the exterior siding around the window. Seek professional assistance regarding this issue.

### LEVEL INDICATOR

Accurate measurements are essential in determining level and plumb. Most carpenters' levels have several bubble level indicators, making it possible to measure all parts of the window.

Examine the horizontal indicator. If the bubble is centered between the lines of the indicator, it is level.

If the bubble is not exactly centered, measure how far “out of level” or “out of plumb” by maneuvering the end of the level until the bubble is exactly centered. Measure the farthest gap between the level and the surface. On a 2' level, the gap must not exceed 1/16", or on a 4' level (or longer), the gap must not exceed 1/8", or the surface is out of level/plumb.

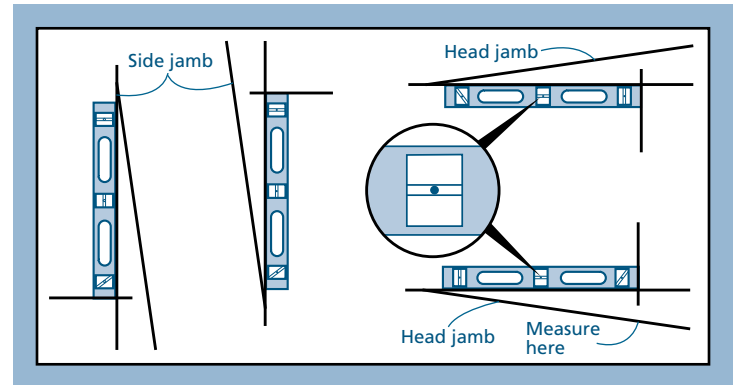

### SQUARE

Measure frame/sash from top left to bottom right corner and from top right to bottom left corner. If measurements differ by 1/8" for windows up to 20 sq. ft. or 1/4" for windows larger than 20 sq.ft., unit is out-of-square.

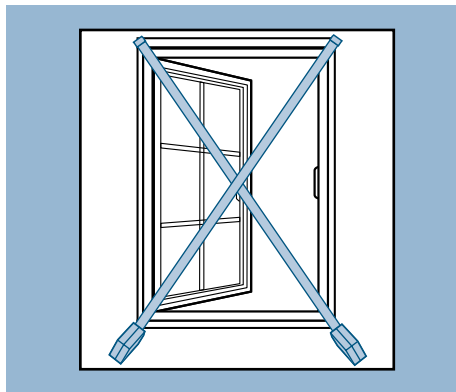

### FRAME TWISTS

Attach two pieces of string to frame/sash, corner to corner. If there is a gap between strings at center point larger than 1/8" for windows up to 4' wide or high, or 3/16" for windows larger than 4' wide or high, the frame is not flat. Repeat by switching strings and re-measuring.

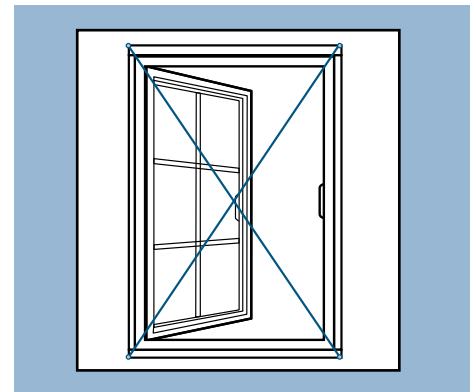

### LEVEL AND PLUMB

For plumb, place level against each side jamb or use a plumb bob. For level, place level against head jamb and sill.

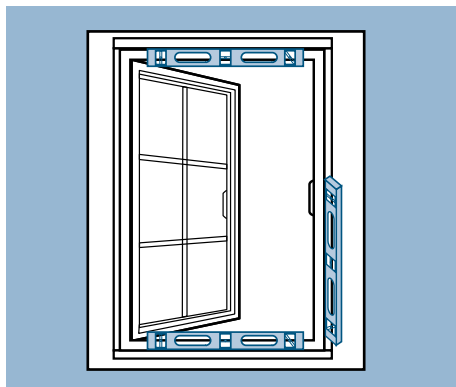

### PROPER SHIMMING

Measure width of frame at top, center, and bottom. If any two measurements differ more than 1/16", the frame is over or under shimmed. Repeat process and measure height of frame.

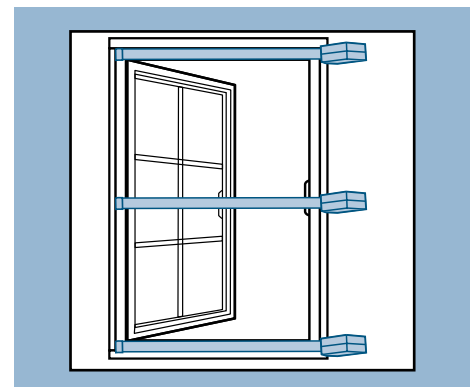

PROPER WINDOW INSTALLATION - CONTINUED

STRAIGHT SIDE JAMBS

Place level against inside of side jamb. Look for gaps anywhere between level and side jamb. Repeat steps for other side jamb.

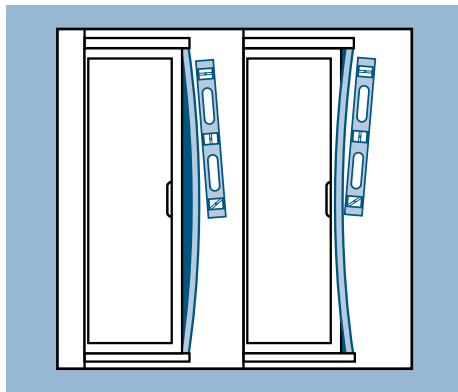

FRAME/PANEL BOW

Inspect interior and exterior frame jambs, or stiles/rails of panel (not glass) to determine if bowed.

1. Cut piece of string slightly longer than height of frame or panel.
2. Pull tightly and stretch string to upper and lower corners of jambs, or, stiles or rails of panel. Tape securely.
3. Look for gap between string and frame or panel. If gap measures more than 1/16" at any point, the panel is bowed.

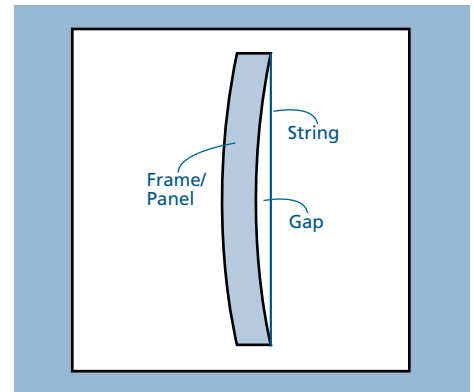

TROUBLESHOOTING OPERATIONAL PROBLEMS

**Note!** Please check each possible cause, including verifying proper installation, before contacting us for assistance.

PROBLEM	POSSIBLE CAUSES	POSSIBLE SOLUTIONS
Sash will not open	Sash locked	Make sure lock latch is in unlocked position, try again
	Obstructions	Remove obstructions/shipping blocks
	Sash may need adjustment (sash drags on sill or does not fit square or flush in the frame)	Adjust operator arm, operator track, or install shim button.
	Sash damaged	Repair or replace sash
	Lock damaged or broken	Replace lock
	Keeper loose or damaged	Tighten if loose, replace if damaged
	Weatherstrip loose or damaged	Reattach If loose, replace if damaged
	Operator damaged	Replace operator.
	Operator arm has disengaged from sash or needs adjustment	Adjust operator arm.
	Crank operator teeth inside handle could be stripped	Replace operator handle.
Improper installation	Inspect installation	
Sash will not close	Sash locked	Make sure lock latch is in unlocked position, try again
	Obstructions	Remove obstructions/shipping blocks
	Hardware dirty and needs lubrication	Clean and lubricate hardware.
	Operator arm loose	Reattach operator arm.
	Sash may need adjustment	Adjust sash.
	Weatherstrip loose or damaged	Reattach If loose, replace if damaged.
	Hinge track screws loose or missing	Hand-tighten screws if loose. Replace if missing.
	Hinge loose or damaged	Hand-tighten screws if loose. Replace if damaged.
	Keeper loose or damaged	Reattach If loose, replace if damaged
	Lock latch misaligned or damaged	Adjust if misaligned, replace if damaged
Improper installation	Inspect installation	

PROBLEM	POSSIBLE CAUSES	POSSIBLE SOLUTIONS
Sash binds or drags	Hinge track dirty	Clean sill track then lubricate with silicone spray on cloth. Clean and lubricate hinge track.
	Obstructions	Remove obstructions/shipping blocks
	Operator arm/hinge bent	Disconnect and straighten.
	Sash may need adjustment (sash drags on sill or does not fit square or flush in the frame)	Adjust operator arm, operator track, or install shim button.
	Weatherstrip loose or damaged	Reattach if loose, replace if damaged.
	Hardware loose, misaligned or damaged	Tighten loose hardware. Re-align if misaligned. Replace if damaged.
	Improper installation	Inspect installation
Sash will not lock properly	Lock misaligned or damaged	Realign if misaligned, replace if damaged
	Sash may need adjustment (sash drags on sill or does not fit square or flush in the frame)	Adjust operator arm, hinge, or install shim button.
	Improper installation	Inspect installation
Sash appears crooked in frame	Obstructions	Remove obstructions/shipping blocks
	Sash may need adjustment	Adjust operator arm, operator track, or install shim button.
	Improper installation	Inspect installation
The window surface fogs up	Condensation. See also our condensation document at: <a href="http://www.jeld-wen.com/_pdf/JGI012.pdf">http://www.jeld-wen.com/_pdf/JGI012.pdf</a>	<p>If condensation is on an interior surface:</p> <ul style="list-style-type: none"> <li>• Raise the average temperature of the house one or two degrees and do not block vents.</li> <li>• Vent all appliances to the outdoors and run exhaust fans.</li> <li>• Open window blinds for air circulation.</li> <li>• Turn humidifiers down as the temperature gets colder (unless used for medical purposes).</li> </ul> <p>If condensation is on an exterior surface:</p> <ul style="list-style-type: none"> <li>• Close window coverings to reduce cooling of the glass surface by air-conditioning.</li> <li>• Remove or trim shrubbery close to windows to promote air circulation.</li> </ul> <p>If condensation is between glass panes:</p> <ul style="list-style-type: none"> <li>• Seal failure. Replace either the insulating glass assembly or the entire sash. This determination should be made by a service representative.</li> </ul>
Water leaks through the window	Clogged weep system	Clean sill track with vacuum or damp cloth and pour small amount of water into interior sill track. If water doesn't drain out, inspect the exterior and clear any blockage. If not blocked, insert thin wire into weep hole (do not insert wire if the weep system has an exterior crevice). Repeat until water runs through weep hole.
	Weatherstrip damaged or missing	Reattach If loose, replace if damaged
	Sash may need adjustment	Adjust operator arm, operator track, or install shim button.
	Sash damaged or loose at joints	Replace sash



## GLOSSARY

**Awning Window**

A window with a sash that is hinged at the top and opens from the bottom.

**Casement Window**

A casement window is hinged on either side so the sash opens outward, to the right or left, in a swinging motion. It provides maximum ventilation.

**Direct-set**

The window's glass is secured directly into the window frame without the stiles and rails of a sash.

**Hinge**

A jointed or flexible device on which a door or window turns.

**Hinge Track**

The part of a bar hinge that allows the pivot point of an awning or casement sash to slide as the window opens and closes.

**Keeper**

A bracket utilized as a latching point for locking systems.

**Kerf**

A groove that often holds weatherstrip.

**Left Hinge (LH)**

Hinge location on a casement as viewed from the outside.

**Mulled Unit**

Two or more window units structurally joined together.

**Multi-point Lock**

A locking system that has multiple locking points with the system's mechanism hidden behind the side screen stops. The locking points engage into keepers located on the sash.

**Operator**

The hardware mechanism used to open and close a window, excluding the hinges.

**Operator Cover**

The cover at the bottom of an operating casement or awning window that covers the mechanical operator of the window.

**Right Hinge (RH)**

Hinge location on a casement as viewed from the outside.

**Sash**

An assembly comprised of stiles (vertical pieces), rails (horizontal pieces) and the window's glass.

**Sash Lift Button**

A "button" placed in the lower sash hinge that slightly lifts the casement window sash as it closes.

**Sash Riser Block**

A block placed in the sill track that slightly lifts the sash as it closes.

**Single-point Lock**

A single-point locking mechanism that uses a "cam" action to lock and to pull the window sash against the frame forming a tight weather seal. Large windows may have more than one lock.

**Weatherstrip**

A strip of material that covers the joint between two separate parts of a window and is used to prevent rain, snow, and cold air from entering.

**Weep Hole**

The visible exit or entry part of a water drainage system used to drain water out of a window unit.