



This guide contains procedures for common user serviceable repair tasks found on aluminum patio doors. If a condition arises that is not covered in this guide, please contact us for professional help. This product guide covers our current JELD-WEN Premium and Builders Series patio doors as well as our historical products with the following names: Seasonshield, Windowmaster, Wenco and Summit. For help identifying your patio door model, refer to your product purchase paperwork or call us for additional help.

Do-It-Yourself

Technician



INTRODUCTION

Sliding/Rolling patio doors consist of at least two side-by-side panels, one may be a fixed panel and at least one is an operating panel (options also include multiple panel patio doors with three or more panels). The operating panel(s) slide back and forth horizontally to open and close. An insect screen is mounted on the exterior side of the operating panel(s).

CONTACT US

For questions, feel free to contact us by phone or email:

- Email: customerserviceagents@jeld-wen.com
- Phone: 1-(800)-JELD-WEN/1-(800)-535-3936

TABLE OF CONTENTS

Precautions and Safety	2
Needed Tools	2
Panel Removal & Installation	2
Hardware Adjustment	3
Check for Proper Installation	4
Troubleshooting Operational Problems	5
Glossary.....	6

SLIDING/ROLLING PATIO DOOR ANATOMY

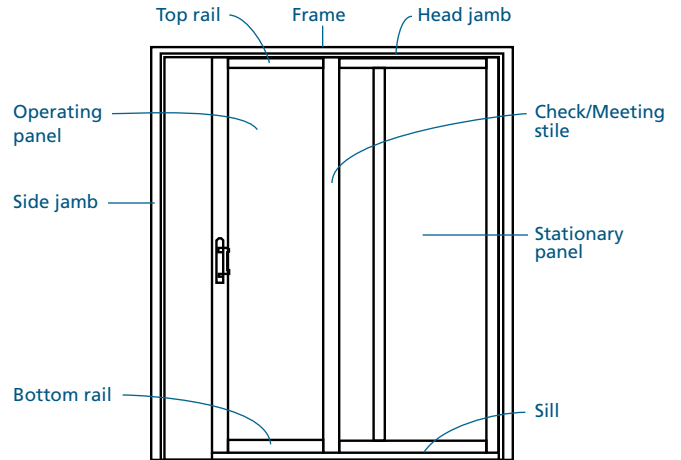

The advice offered herein can be done by a homeowner with some mechanical aptitude. If you are unsure, it is recommended that you hire a trained service provider such as a competent and licensed construction contractor or building professional. JELD-WEN disclaims any and all liability associated with the use and/or provision of these instructions. Any reliance upon the information or advice is at the risk of the party so relying. The information contained herein may be changed from time to time without notification.

PRECAUTIONS & SAFETY

- Follow all manufacturers' instructions and labels.
- Use proper and safe equipment and precautions when cleaning and servicing the exterior side of patio doors above ground level.
- Insect screens are not security devices and will not prevent a child, other person, or pet from falling through.
- Use extra care when driving screws near glass unit to avoid breakage.
- Use caution when tightening screws to avoid stripping the screw holes.
- Panel removal can be awkward and could cause physical injury or product damage; we recommend the help of a second person.

NEEDED TOOLS & MATERIALS

NEEDED TOOLS

Note! Each tool is not required for every task.

- Phillips head screwdriver
- 2' or 4' Level
- Tape measure
- Putty knife

NEEDED MATERIALS

- String
- Tape

PANEL REMOVAL & INSTALLATION

Panel removal can be awkward and could cause physical injury or product damage; we recommend the help of additional people.

OPERATING PANEL REMOVAL

Operating panel(s) normally remove to the interior. Some doors have a sill riser that will prevent the panel from being removed to the interior. The fixed panel(s) will then need to be removed before the operating panel(s), then the operating panel(s) can be removed to the exterior. Follow the instructions for fixed panel removal, if necessary, before attempting to remove the operating panel(s).

1. On the interior, unlock panel and slide to the middle or further past the anti-lift blocks in the head.
2. Lift panel up and over bottom track and remove to the interior. The rollers may need to be adjusted up into the panel and then held with a putty knife or similar flat tool in order to clear the sill track.

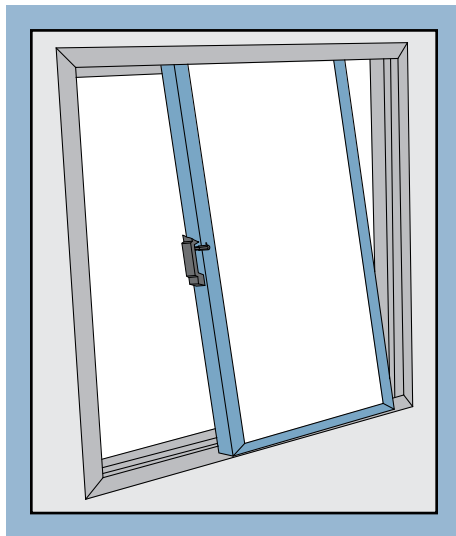

INSTALLATION

To install, reverse removal steps.

FIXED PANEL REMOVAL

The fixed panel(s) will either be glass directly set in the frame (not removable), held in place with screws, or held in place with a bracket and screws. Fasteners may be hidden behind a cover that is snapped into the track of the door frame. For additional assistance with identifying whether a fixed panel is removable or not, please contact us.

1. Once the fasteners are removed, slide the panel away from the jamb.
2. Lift the panel up into the head and up and over the sill track toward the exterior.

INSTALLATION

To install, reverse removal steps.

HARDWARE ADJUSTMENT

ROLLER ADJUSTMENT

Note! Adjusting door too high may allow water and air leakage. Adjust rollers just high enough to clear sill track and keep the weatherstrip hidden when the door is closed.

1. Doors will have an adjustment screw near each lower corner of each operating panel located on the end or face. Remove small vinyl plugs from each hole (if present).
2. Open operating panel enough to compare with frame jamb.

Note! Roller adjustment screws located on the end are in close proximity to the attachment screw. Adjust only the lower screw (as shown); loosening the attachment screw will detach the roller from the operating panel.

3. Lift the panel to take the weight off of the roller and turn the adjustment screw with a #2 Phillips head screwdriver (do not use a power driver). Clockwise rotations raise the panel, and counterclockwise rotations lower the panel.
4. Adjust as needed until interlocks, grid patterns, and jambs line up.
5. Test the operating panel(s) for proper operation.
6. Re-apply the small vinyl caps over the roller adjustment screw holes if applicable.

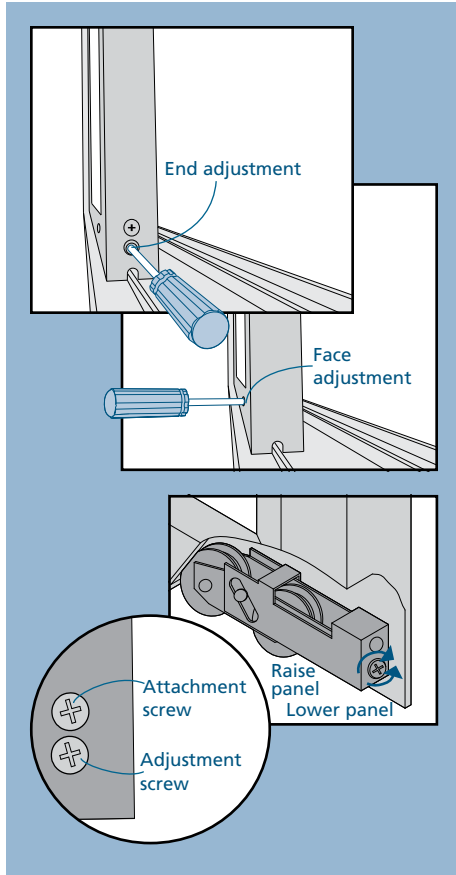

LOCK ADJUSTMENT

Some locks are not adjustable. Adjustable locks will have a lock hook adjustment screw and non-adjustable locks will not. Keepers vary in design, but operate similarly.

IF THE LOCK DOES NOT PROPERLY ENGAGE THE STRIKE PLATE

Loosen the strike plate screws and move up or down until the latch engages properly.

IF THE DOOR DOES NOT LOCK OR IS LOOSE WHEN LOCKED

Turn the lock hook adjustment screw(s) in 1/2 turn increments clockwise to extend the hook, loosening the locking mechanism, or counterclockwise to retract the hook and tighten the locking mechanism. Some doors have a double latch and two adjustment screws.

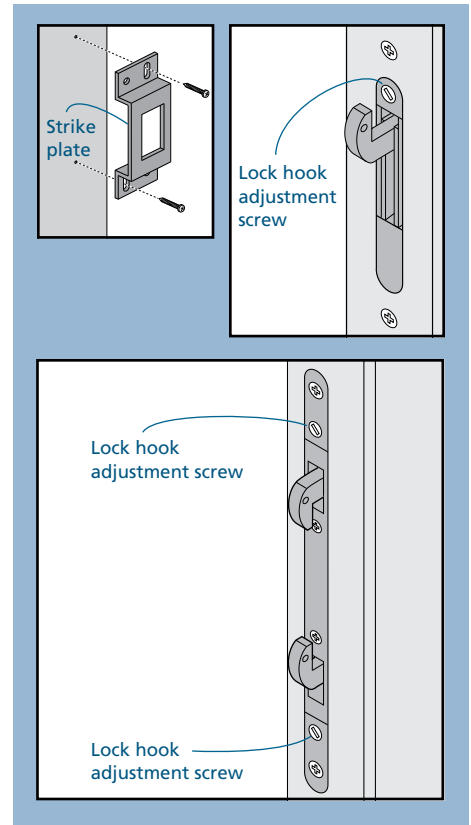

PROPER PATIO DOOR INSTALLATION

- Proper installation is essential for keeping patio doors operating smoothly. If a patio door fails to operate properly, an inspection is necessary to determine if it was installed correctly.
- A contractor or installer can assist in determining the cause of a patio door being “out of specification” and possibly correct it. Patio door problems due to improper installation are usually not covered by the manufacturer’s warranty. For installation instructions, contact us or your supplier.
- The specifications and measurements referenced in this guide are taken from ASTM E2112 Standard Practice for Installation of Exterior Windows, Doors and Skylights.

Note: These instructions do not address inspection for proper “water tightness” or flashing. A “water tight” inspection requires removal of the exterior siding around the patio door. Seek professional assistance regarding this issue.

LEVEL INDICATOR

Accurate measurements are essential in determining level and plumb. Most carpenters’ levels have several bubble level indicators, making it possible to measure all parts of the patio door.

Examine the horizontal indicator. If the bubble is centered between the lines of the indicator, it is level.

If the bubble is not exactly centered, measure how far “out of level” or “out of plumb” by maneuvering the end of the level until the bubble is exactly centered. Measure the farthest gap between the level and the surface. On a 2’ level, the gap must not exceed 1/16”, or on a 4’ level (or longer), the gap must not exceed 1/8”, or the surface is out of level/plumb.

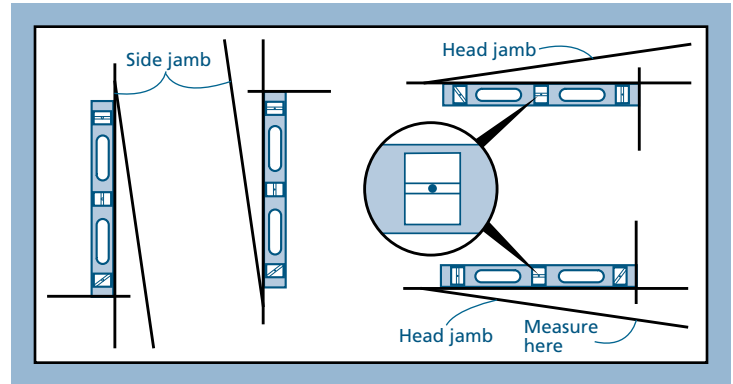

SQUARE

Measure frame/ panel from top left to bottom right corner and from top right to bottom left corner. If measurements differ by 1/8” for patio doors up to 20 sq. ft. or 1/4” for patio doors larger than 20 sq.ft., unit is out-of-square.

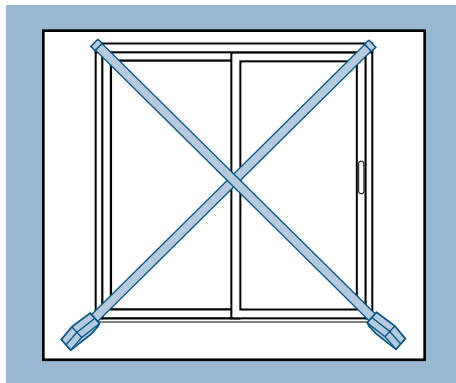

FRAME TWISTS

Attach two pieces of string to frame/panel, corner to corner. If there is a gap between strings at center point larger than 1/8” for patio doors up to 4’ wide or high, or 3/16” for patio doors larger than 4’ wide or high, the frame is not flat. Repeat by switching strings and re-measuring.

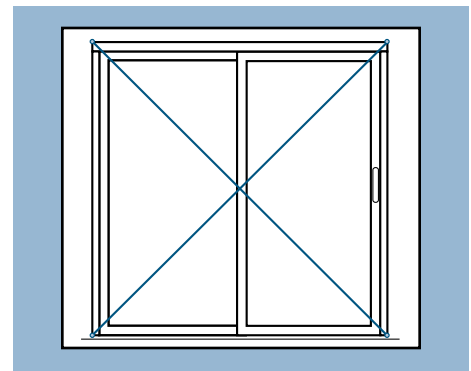

LEVEL AND PLUMB

For plumb, place level against each side jamb or use a plumb bob. For level, place level against head jamb and sill.

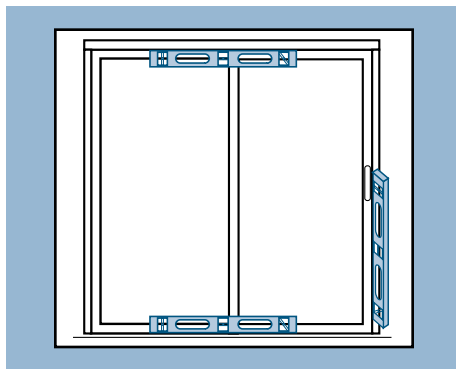

PROPER SHIMMING

Measure width of frame at top, center, and bottom. If any two measurements differ more than 1/16”, the frame is over or under shimmed. Repeat process and measure height of frame.

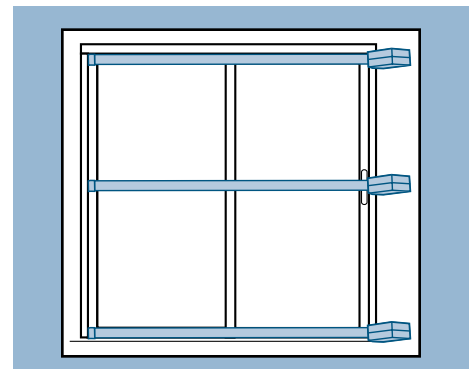

PROPER PATIO DOOR INSTALLATION - CONTINUED

STRAIGHT SIDE JAMBS

Place level against inside of side jamb. Look for gaps anywhere between level and side jamb. Repeat steps for other side jamb.

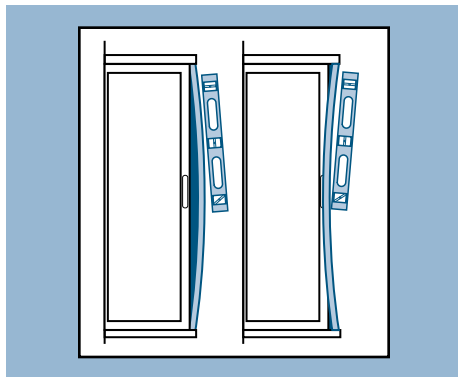

FRAME/PANEL BOW

Inspect interior and exterior frame jambs, or stiles/rails of panel (not glass) to determine if bowed.

1. Cut piece of string slightly longer than height of frame or panel.
2. Pull tightly and stretch string to upper and lower corners of jambs, or, stiles or rails of panel. Tape securely.

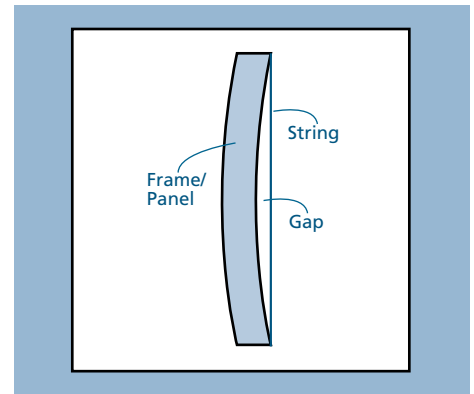

3. Look for gap between string and frame or panel. If gap measures more than 1/16" at any point, the panel is bowed.

TROUBLESHOOTING OPERATIONAL PROBLEMS

Note! Please check each possible cause, including verifying proper installation, before contacting us for assistance.

PROBLEM	POSSIBLE CAUSES	POSSIBLE SOLUTIONS
Panel will not open	Sill track dirty	Clean sill track then lubricate with silicone spray on cloth.
	Panel locked	Make sure lock latch is in unlocked position, try again.
	Obstructions	Remove obstructions/shipping blocks
	Panel damaged	Repair or replace panel
	Lock damaged or broken	Replace lock
	Keeper loose or damaged	Tighten if loose. Replace if damaged.
	Weatherstrip loose or damaged	Reattach If loose, replace if damaged.
	Panel may need adjustment (panel drags on sill or does not fit square or flush in the frame)	Adjust rollers
Panel will not close	Improper installation	Inspect installation
	Sill track dirty	Clean sill track then lubricate with silicone spray on cloth.
	Panel locked	Make sure lock latch is in unlocked position. Try again.
	Obstructions	Remove obstructions/debris/shipping blocks.
	Keeper loose or damaged	Tighten if loose. Replace if damaged.
	Weatherstrip loose or damaged	Reattach If loose, replace if damaged.
	Panels do not line up at check (meeting) rails/stiles	Adjust rollers
Improper installation	Inspect installation	

PROBLEM	POSSIBLE CAUSES	POSSIBLE SOLUTIONS
The patio door surface fogs up	Condensation.	<p>If condensation is on an interior surface:</p> <ul style="list-style-type: none"> • Raise the average temperature of the house one or two degrees and do not block vents. • Vent all appliances to the outdoors and run exhaust fans. • Open patio door blinds for air circulation. • Turn humidifiers down as the temperature gets colder (unless used for medical purposes). <p>If condensation is on an exterior surface:</p> <ul style="list-style-type: none"> • Close patio door coverings to reduce cooling of the glass surface by air-conditioning. • Remove or trim shrubbery close to patio doors to promote air circulation. <p>If condensation is between glass panes:</p> <ul style="list-style-type: none"> • Seal failure. Replace either the insulating glass assembly or the entire panel. This determination should be made by a service representative.
Panel appears crooked in frame	Panel may need adjustment	Adjust rollers
	Obstructions	Remove obstructions / shipping blocks
	Improper installation	Inspect installation
Water leaks through the patio door	Clogged weep system	<p>Clean sill track with vacuum or damp cloth and pour small amount of water into interior sill track. If water doesn't drain out, inspect the exterior and clear any blockage. If not blocked, insert thin wire into weep hole (do not insert wire if the weep system has an exterior crevice).</p> <p>Repeat until water runs through weep hole.</p>
	Weatherstrip damaged or missing	Reattach if loose, replace if damaged or missing

GLOSSARY

Interlock

An interlock on a patio door provides a hooking action between the panel stiles. This action reduces air infiltration and increases security.

Jamb

The vertical frame members of a window or patio door assembly.

Keeper

A bracket utilized as a latching point for locking systems.

Panel

An assembly comprised of stiles (vertical pieces), rails (horizontal pieces) and the patio door's glass.

Rail

The horizontal members of a window or patio door panel.

Roller

A roller is the round wheel used in a sliding window or patio door on which the operating sash or panel travels. For this reason, a sliding window/patio door may also be called a rolling window/patio door.

Sill track

The track on the sill of a patio door that guides the panel as it opens and closes.

Stile

The vertical members of a window or patio door panel.

Weatherstrip

A strip of material that covers the joint between two separate parts of a patio door and is used to prevent rain, snow, and cold air from entering.